

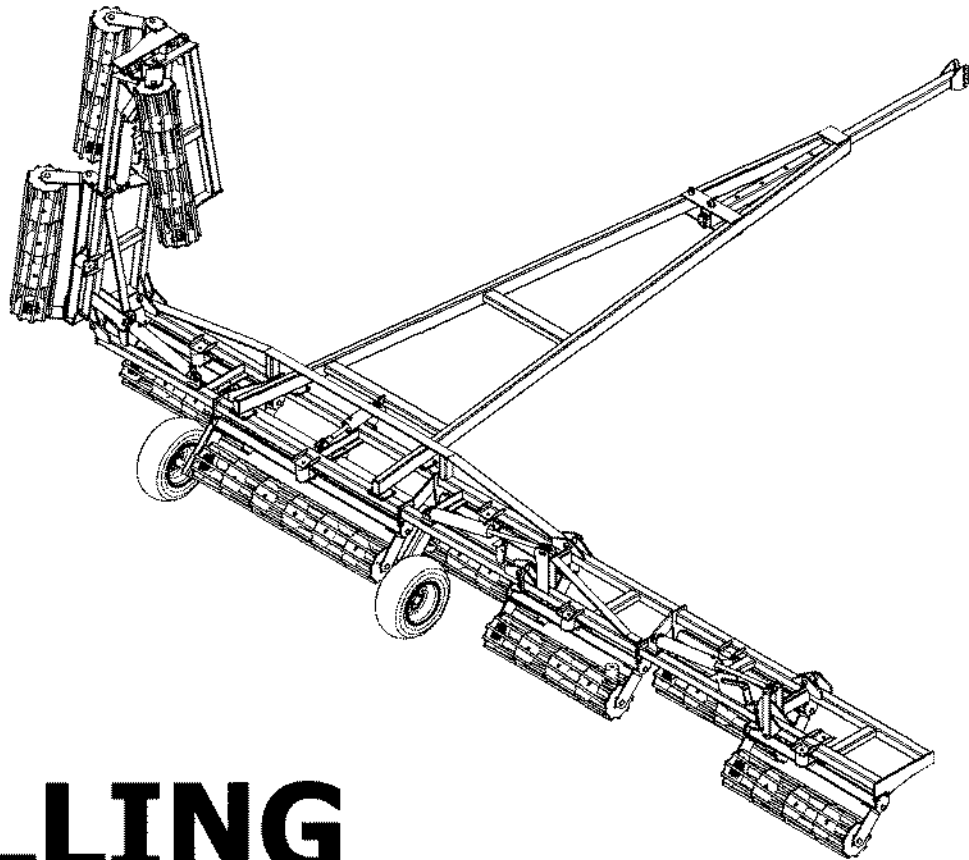



# ASSY/OPERATORS/ PARTS MANUAL



# ROLLING PACKER

Printed in USA (79303) J&M 1/07

 **WIL-RICH**  
PO Box 1030  
Wahpeton, ND 58074  
PH (701) 642-2621  
Fax (701) 642-3372





**PERSONAL SAFETY IS IMPORTANT!**

ALL PERSONNEL INVOLVED WITH THE ASSEMBLY AND/OR OPERATION OF THIS EQUIPMENT MUST BE INFORMED OF PROPER SAFETY PROCEDURES. OPERATOR'S AND ASSEMBLY MANUALS PROVIDE THE NECESSARY INFORMATION. IF THE MANUAL IS LOST FOR A PARTICULAR IMPLEMENT, ORDER A REPLACEMENT AT ONCE. OPERATOR'S AND ASSEMBLY MANUALS ARE AVAILABLE AT NO CHARGE UPON REQUEST.

ADDRESS INQUIRIES TO:

WIL-RICH

PO BOX 1030

WAHPETON, ND 58074

PH (701)642-2621 FAX (701)642-3372



## ASSEMBLY INFORMATION

Remove all wires and arrange the parts conveniently.

**NOTE:** Always wear safety glasses or goggles and be careful when cutting wires and steel bands as they are under tension and will spring back when cut.

Wherever the terms "left" and "right" are used, it must be understood to mean from a position behind and facing the machine.

Lubricate all bearings and moving parts as you proceed and make sure they work freely.

Loosely install all bolts connecting mating parts before final tightening.

When tightening bolts, they must be torqued to the proper number of foot-pounds as indicated in the table unless specified. It is important that all bolts be kept tight.

On new machines, all nuts and bolts must be re-checked after a few hours of operation.

When replacing a bolt, use only a bolt of the same grade or higher. Except in shear bolt applications, where you must use the same grade bolt.

Bolts with no markings are grade 2

Grade 5 bolts furnished with the machine are identified by three radial lines on the head.

Grade 8 bolts furnished with the machine are identified by six radial lines on the head.

All U-bolts are grade 5.



THIS SYMBOL USED TO CALL YOUR ATTENTION TO INSTRUCTIONS CONCERNING YOUR PERSONAL SAFETY. BE SURE TO OBSERVE AND FOLLOW THESE INSTRUCTIONS

	GRADE 2		GRADE 5			GRADE 8	
TORQUE IN FOOT POUNDS							
BOLT DIA	3/8	1/2	5/8	3/4	7/8	1	
HEX HEAD	9/16	3/4	15/1	1-1/8	1-5/1	1-1/2	
UNC GR2	18	45	89	160	252	320	
UNC GR5	30	68	140	240	360	544	
UNC GR8	40	100	196	340	528	792	
UNF GR2	21	51	102	178	272	368	
UNF GR5	32	70	168	264	392	572	
UNF GR8	48	112	216	368	792	840	

**CAUTION**

**TO AVOID INJURY AND/OR MACHINE DAMAGE:**

- Refer to Operator's Manual for safety instructions.
- Do not stand or climb on machine when operating.
- Use clean hazard flashers and SMV sign when transporting.
- Observe highway traffic regulations.

23325

**CAUTION**

Failure to follow these instructions may result in personal injury and/or equipment damage.

- Just before and during operation be sure no one is on or around the implement.
- Before activating the hydraulic system, check hoses for proper connections.
- Before lowering the wings for the first time, make sure the entire system has been charged with oil.
- With wings down always install hydraulic cylinder channel lock(s) for transporting.

54374

# 26' THROUGH 51.5' MAIN FRAME AND HITCH

10498	15X8 6B RIM (W511535V PO2)
11364	CLEVIS HITCH
11638	HITCH BOLT
11984	WING LOCK PIN 5/8X4-15/16
12724	HOSE BRACKET ASSY
14131	2" HUB & SPINDLE (LG7830015)
233114	RP 16.5FT MAIN FRAME
233117	TUBE PIVOT MOUNT
233143	RP 16.5FT MAIN AXLE
233159	RP 12& 16.5FT FRONT MAIN POLE
233162	HITCH PIN 1-1/4X7-5/16 (ZINC)
233187	RP 16.5FT MAIN POLE
233212	HEADLESS PIN 1-1/4X7-3/4 (ZINC)
233847	CHAIN WASHER (ZINC)
233848	BUSHING (ZINC)
233849	PLATE (RED)
24415	JACK
24538	WHL ASSY 11LX15 6B 8" 8P GRAY
33998	AXLE CLAMP
42473	HEADLESS PIN(2) 1X2-3/8
42484	1/4 X 2-1/4 ROLL PIN
55174	10K SAFETY CHAIN
59354F	HYD CYL 4XB FGS #A519CY 13
88103	NUT HEX 3/8-16NC 5Z
88110	NUT HEX 3/4-10NC 5Z
88126	NUT HEX 5/8-11NC 5Z
88129	WSHR HLK 5/8ID(11/16ACT) Z
88130	WSHR HLK 3/4ID(13/16ACT) Z
88133	PIN COT 3/16DIA X 2 Z
88137	PIN SPRLK 3/16X3-3/4 PRLS 8 Z
88145	BLT-U 5/8-11NCX4X5-1/4 Z
88162	NUT 2POS LK 3/8-16NC 5P
88304	NUT 2POS LK 1/2-20NF 5P
88305	BLT HEX 3/4-10NCX5 5Z
88318	PIN SPRLK 1/4X4 /CASE 1978739C1
88335	BLT HEX 3/4-10NCX7 5Z
88350	NUT SLTD 1-1/4-7NC 5Z
88362	WSHR HLK 3/8ID Z
88385	BLT-U 3/8-16NCX4X5 Z
88404	BLT HEX 3/4-10NCX2-1/2 5Z
88429	BLT HEX 1/2-20NF X3-1/4 5Z
88487	BLT HEX 3/4-10NCX8-1/2 5Z
88611	NUT NLK 3/4-10NC 5Z
89012	BLT HEX 3/8-16NC X 2-1/2 5Z
89075	NUT NYLON LOCK 1-8NC 5Z
89371	BLT HEX 1-8NCX3-1/2 8YZ

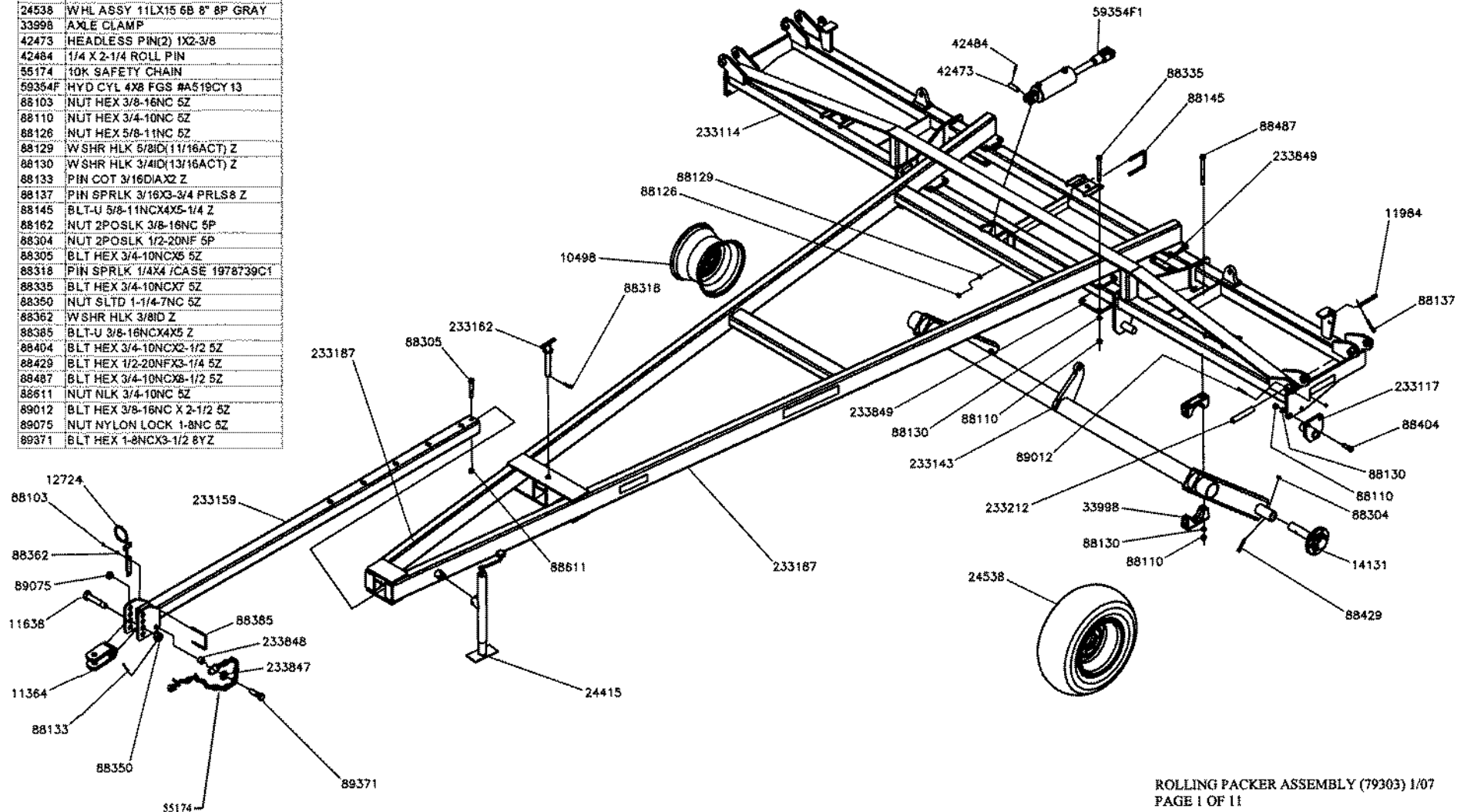

# ROLLING PACKER OUTER WING ASSEMBLY

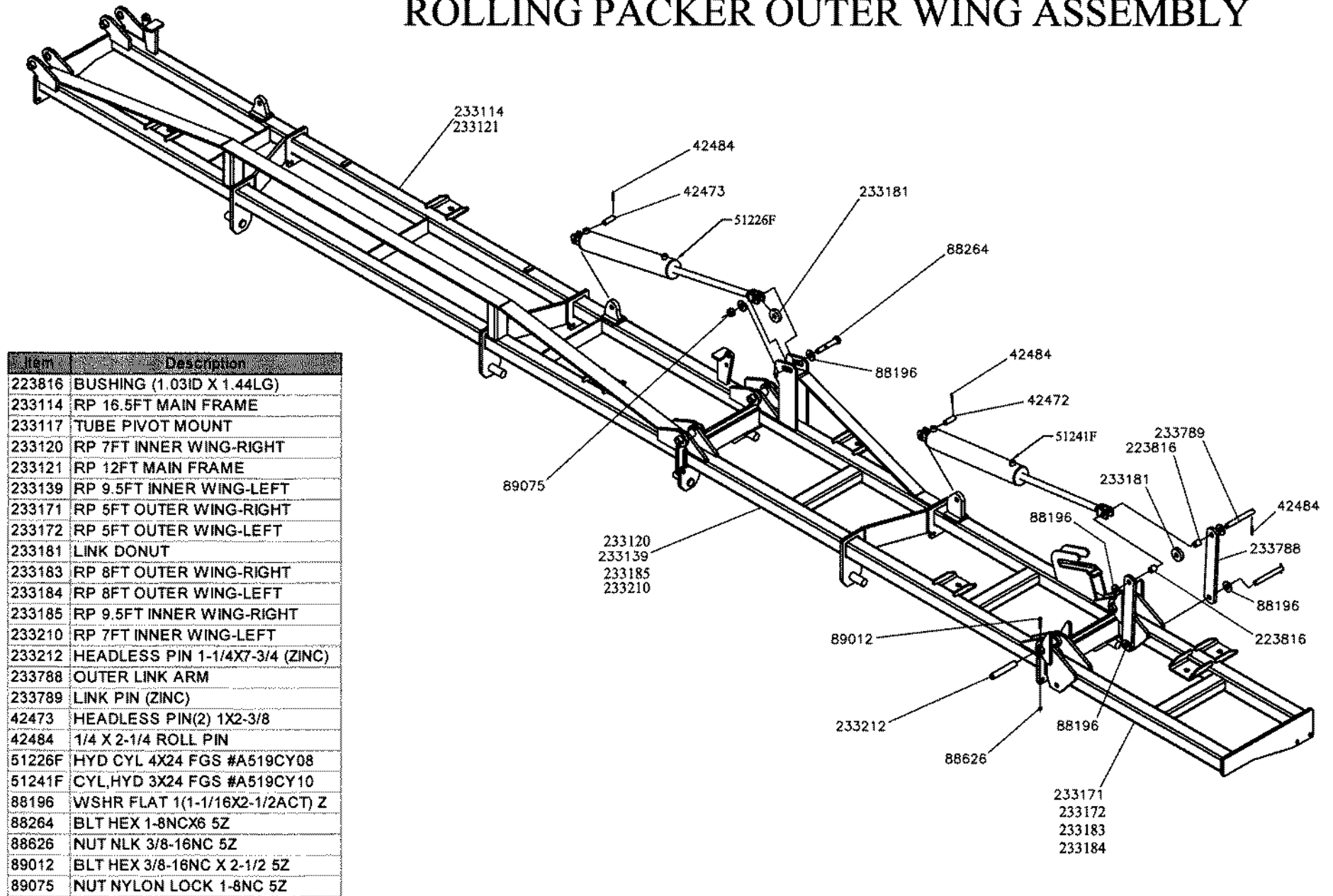

Item	Description
223816	BUSHING (1.03ID X 1.44LG)
233114	RP 16.5FT MAIN FRAME
233117	TUBE PIVOT MOUNT
233120	RP 7FT INNER WING-RIGHT
233121	RP 12FT MAIN FRAME
233139	RP 9.5FT INNER WING-LEFT
233171	RP 5FT OUTER WING-RIGHT
233172	RP 5FT OUTER WING-LEFT
233181	LINK DONUT
233183	RP 8FT OUTER WING-RIGHT
233184	RP 8FT OUTER WING-LEFT
233185	RP 9.5FT INNER WING-RIGHT
233210	RP 7FT INNER WING-LEFT
233212	HEADLESS PIN 1-1/4X7-3/4 (ZINC)
233788	OUTER LINK ARM
233789	LINK PIN (ZINC)
42473	HEADLESS PIN(2) 1X2-3/8
42484	1/4 X 2-1/4 ROLL PIN
51226F	HYD CYL 4X24 FGS #A519CY08
51241F	CYL, HYD 3X24 FGS #A519CY10
88196	WSHR FLAT 1(1-1/16X2-1/2ACT) Z
88264	BLT HEX 1-8NCX6 5Z
88626	NUT NLK 3/8-16NC 5Z
89012	BLT HEX 3/8-16NC X 2-1/2 5Z
89075	NUT NYLON LOCK 1-8NC 5Z

# ROLLING PACKER BASKET ASSEMBLY

Item	Description
88475	BLT HEX 1/2-13NCX1-1/2 5Z
88303	WSHR HLK 1/2ID(9/16ACT) Z
88145	BLT-U 5/8-11NCX4X5-1/4 Z
88129	WSHR HLK 5/8ID(11/16ACT) Z
88126	NUT HEX 5/8-11NC 5Z
88104	NUT HEX 1/2-13NC 5Z
236861	LOCKING COLLAR
236860	SELF-ALIGNING BEARING
233179	BASKET PIVOT TUBE WLD - 45"
233177	45" CRUMBLER BASKET WELD RB
233137	BASKET PIVOT TUBE WLD - 87"
233135	BASKET PIVOT TUBE WLD - 59"
233132	59" CRUMBLER BASKET WELD RB
233131	87" CRUMBLER BASKET WELD RB
233126	BASKET PIVOT TUBE WLD - 101"
222997	BASKET MOUNT WELD
222993	101" CRUMBLER BASKET WELD RB
240887	87 IN FLAT BLADED REEL
240681	45 IN FLAT BLADED REEL
240683	49 IN FLAT BLADED REEL

222993  
233131  
233132  
233177  
240887  
240681  
240683

233126  
233135  
233137  
233179

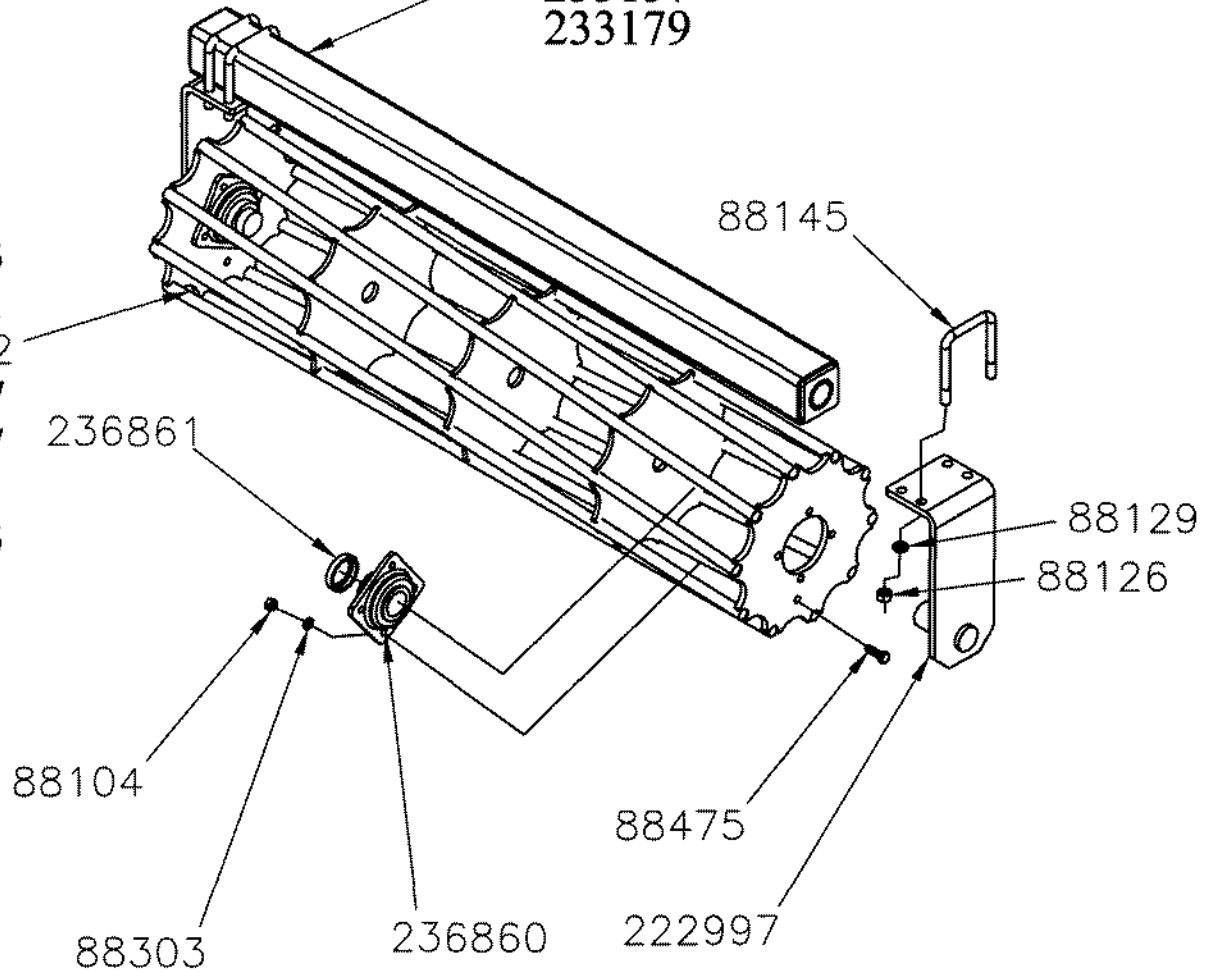

UNIT SIZE (FT)	BASKET ASSEMBLY LOCATIONS										
	BASKET SIZE (IN)										
15	87	87									
23	45	87	87	45							
26	87	45	59	45	87						
31	59	59	45	59	45	59	59				
35.5	59	59	59	87	59	59	59				
36	59	87	45	59	45	87	59				
41	59	59	59	45	59	45	59	59	59		
45.5	59	59	59	59	87	59	59	59	59		
51.5	101	59	59	59	87	59	59	59	101		



# PACKER MOUNTING ASSEMBLY

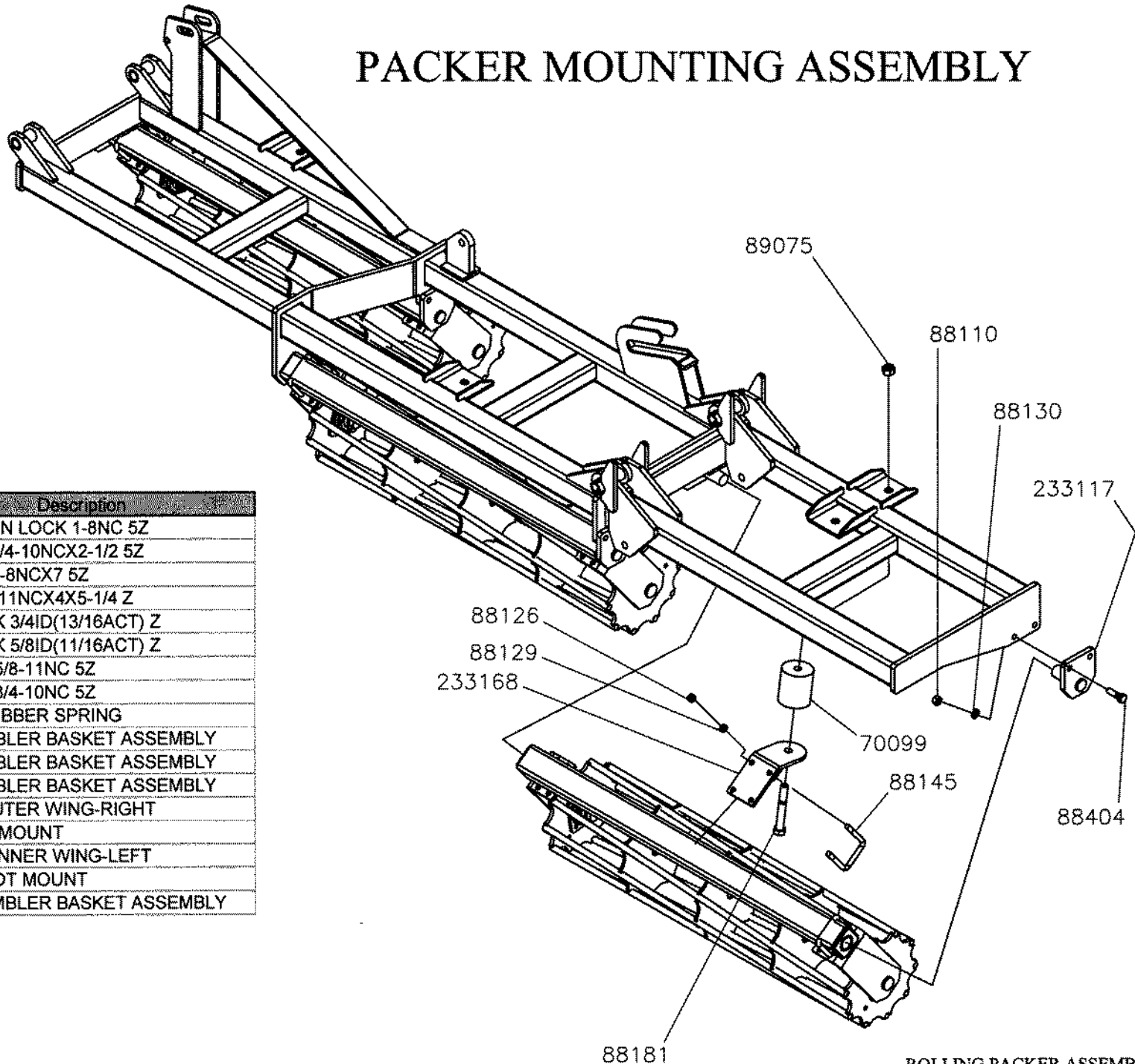

Item	Description
89075	NUT NYLON LOCK 1-8NC 5Z
88404	BLT HEX 3/4-10NCX2-1/2 5Z
88181	BLT HEX 1-8NCX7 5Z
88145	BLT-U 5/8-11NCX4X5-1/4 Z
88130	WSHR HLK 3/4ID(13/16ACT) Z
88129	WSHR HLK 5/8ID(11/16ACT) Z
88126	NUT HEX 5/8-11NC 5Z
88110	NUT HEX 3/4-10NC 5Z
70099	STRUT RUBBER SPRING
234023	87" CRUMBLER BASKET ASSEMBLY
234022	59" CRUMBLER BASKET ASSEMBLY
234021	45" CRUMBLER BASKET ASSEMBLY
233171	RP 5FT OUTER WING-RIGHT
233168	CUSHION MOUNT
233139	RP 9.5FT INNER WING-LEFT
233117	TUBE PIVOT MOUNT
234020	101" CRUMBLER BASKET ASSEMBLY

# 15 AND 23 FLAT BLADE ROLLING PACKER

Item	Description
11364	CLEVIS HITCH
11638	HITCH BOLT
14131	2IN HUB & SPINDLE (LG7830015)
233117	TUBE PIVOT MOUNT
233159	RP 12&16.5FT FRONT MAIN POLE
233162	HITCH PIN 1-1/4X7-5/16 (ZINC)
233175	RP 12FT MAIN AXLE
233212	HEADLESS PIN 1-1/4X7-3/4 (ZINC)
233847	CHAIN WASHER (ZINC)
233848	BUSHING (ZINC)
240795	15 FT ROLLING PACKER FRAME
240796	4 FT ROLLING PACKER WING WELD (RH)
240797	4 FT ROLLING PACKER WING WELD (LH)
24415	JACK
24538	WHL ASSY 11LX15 6B 8" 8P GRAY
10498	RIM
29066	11L x 15 8 PLY TIRE
30784	VALVE STEM
34132	AXLE CLAMP ASSEMBLY (RED)
42473	HEADLESS PIN 1X2-3/8 (ZINC)
42464	1/4 X 2-1/4 ROLL PIN
59354F	HYD CYL 4X8 FGS #A519CY28
88110	NUT HEX 3/4-10NC 5Z
88130	WSHR HLK 3/4ID(13/16ACT) Z
88133	PIN COT 3/16DIA X 2 Z
88318	PIN SPRLK 1/4X4 /CASE 1978739C1
88350	NUT SLTD 1-1/4-7NC 5Z
88404	BLT HEX 3/4-10NCX2-1/2 5Z
88467	BLT HEX 3/4-10NCX8-1/2 5Z
88626	NUT NLK 3/8-16NC 5Z
89012	BLT HEX 3/8-16NC X 2-1/2 5Z
89075	NUT NYLON LOCK 1-8NC 5Z
89371	BLT HEX 1-8NCX3-1/2 8YZ
51240F	CYL HYD 3X12 FGS #A519CY09

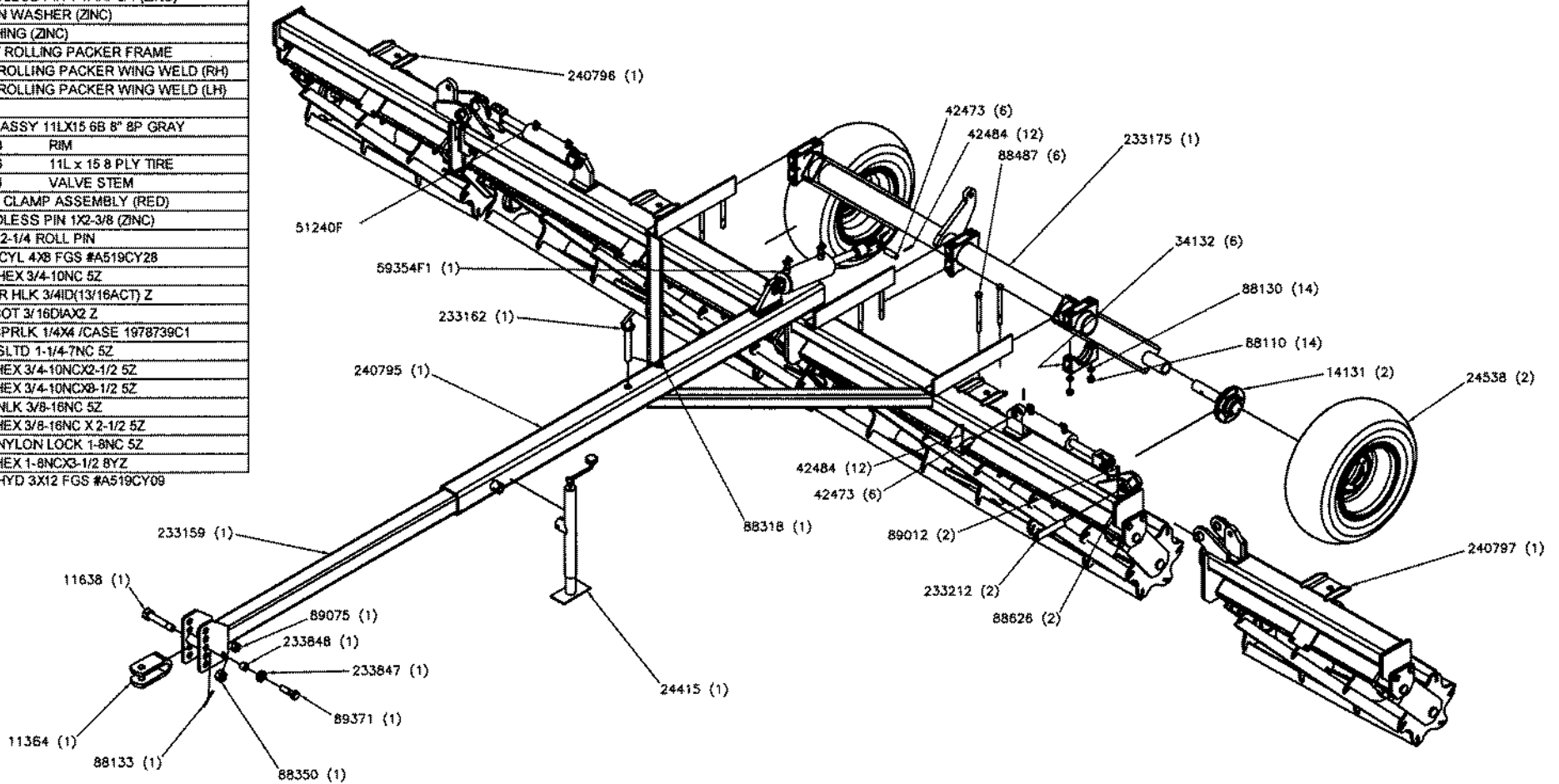

ROLLING PACKER 15 -23 FT  
LIFT & WING FOLD HYDRAULICS

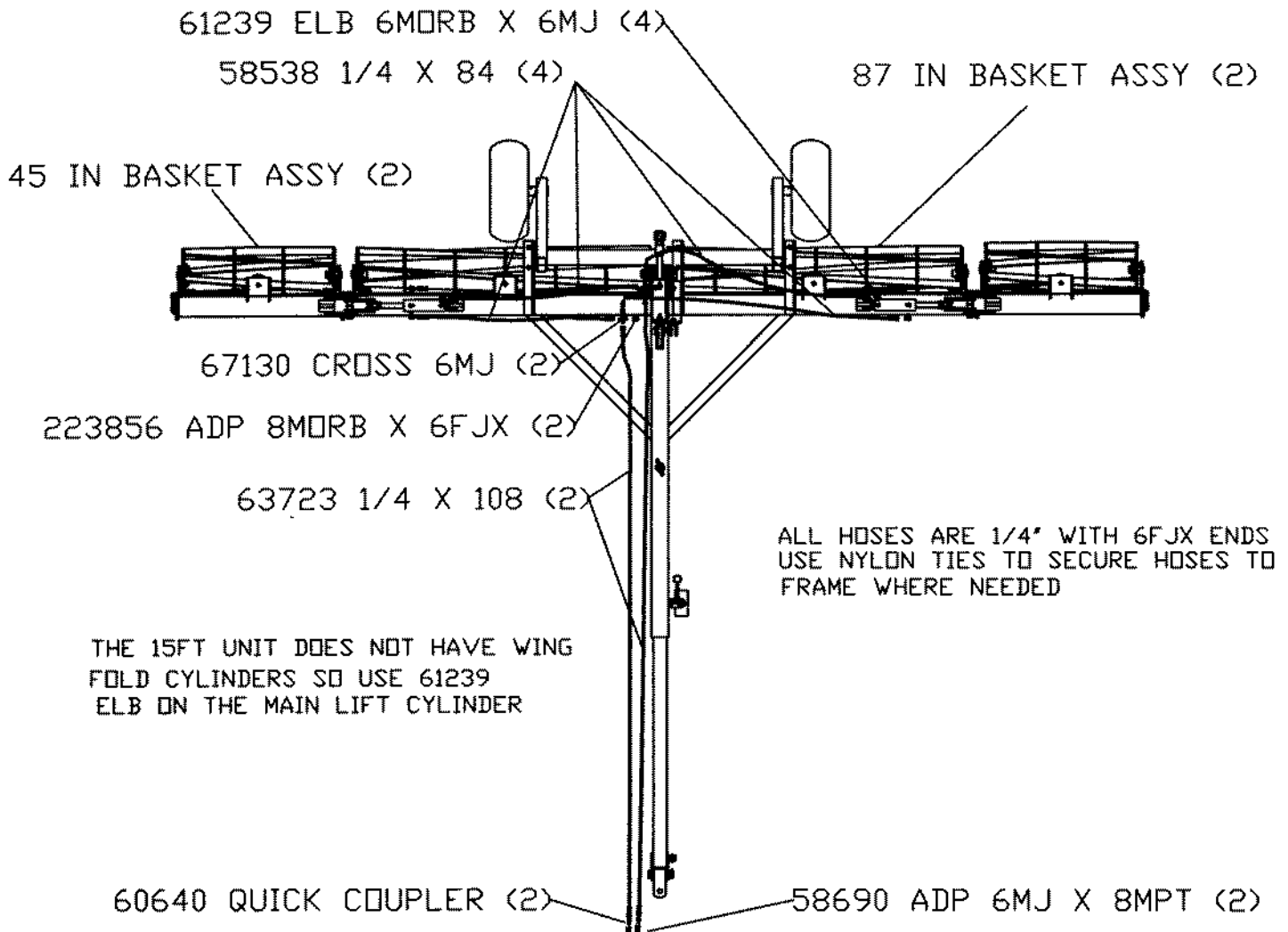

ROLLING PACKER 26 -31 FT  
LIFT & WING FOLD HYDRAULICS

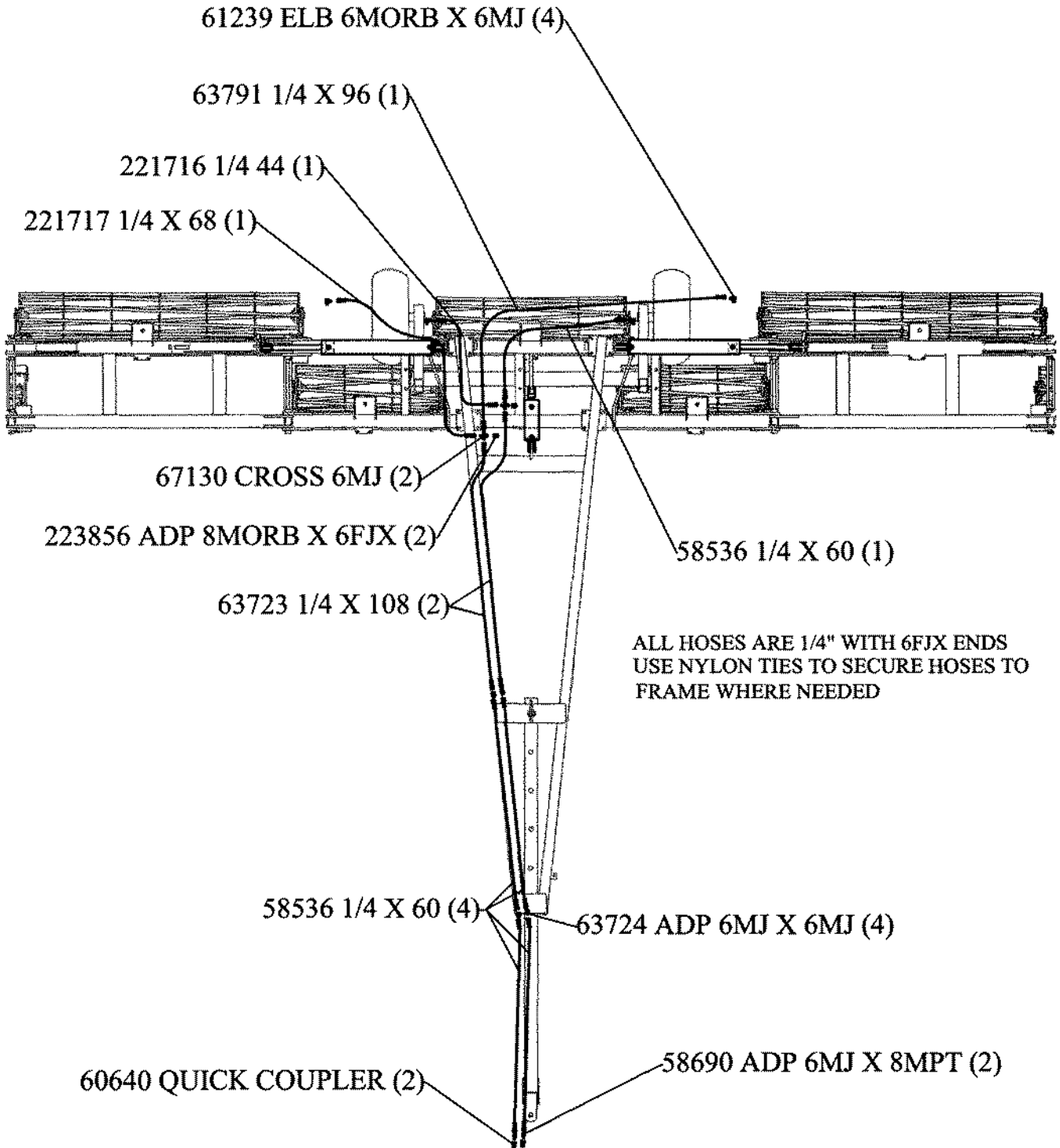

# ROLLING PACKER - 35.5 FT LIFT & WING FOLD HYDRAULICS

ALL HOSES ARE 1/4" WITH 6FJX ENDS  
USE NYLON TIES TO SECURE HOSES TO  
FRAME WHERE NEEDED

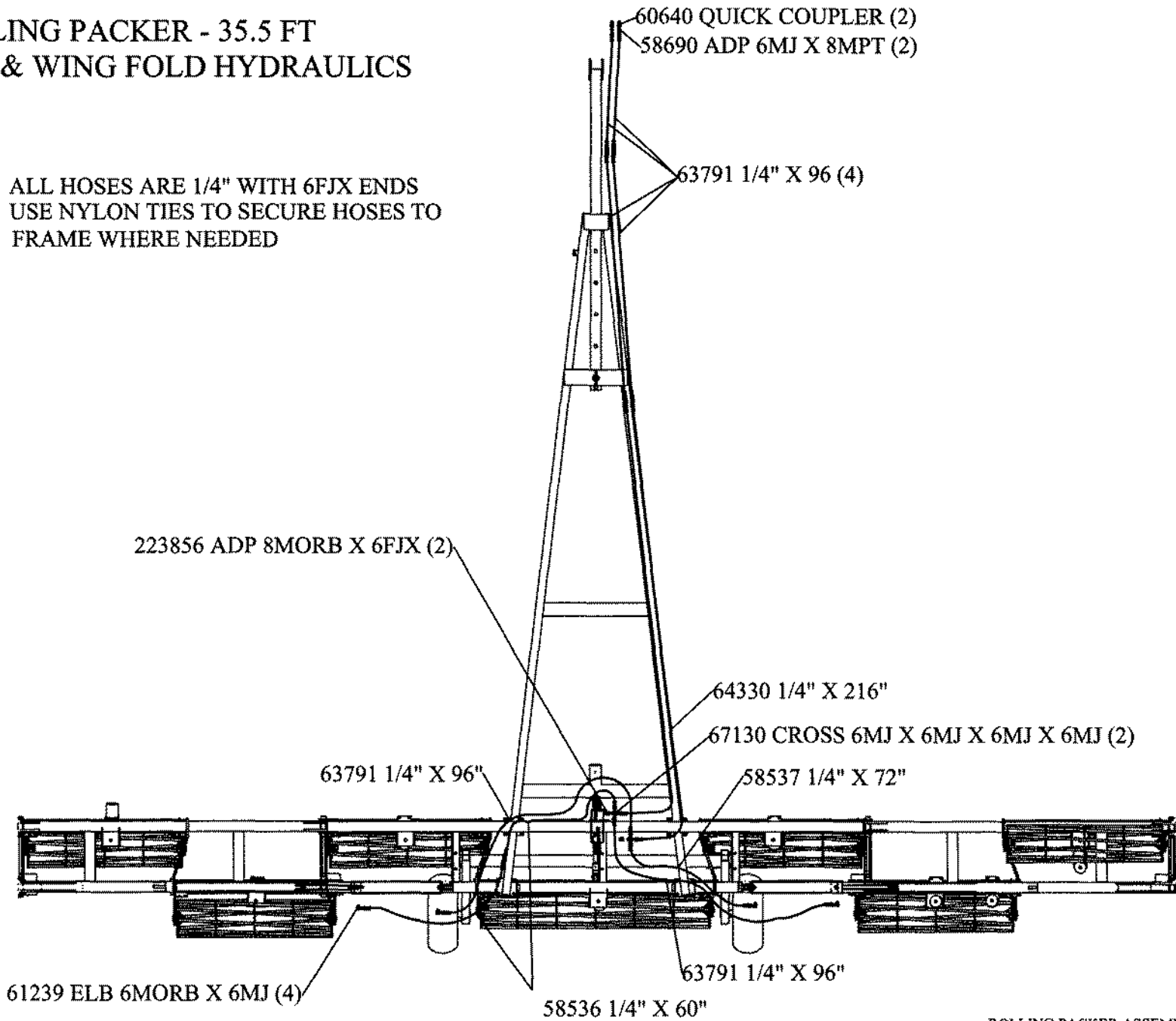

# ROLLING PACKER - 36FT LIFT & WING FOLD HYDRAULICS

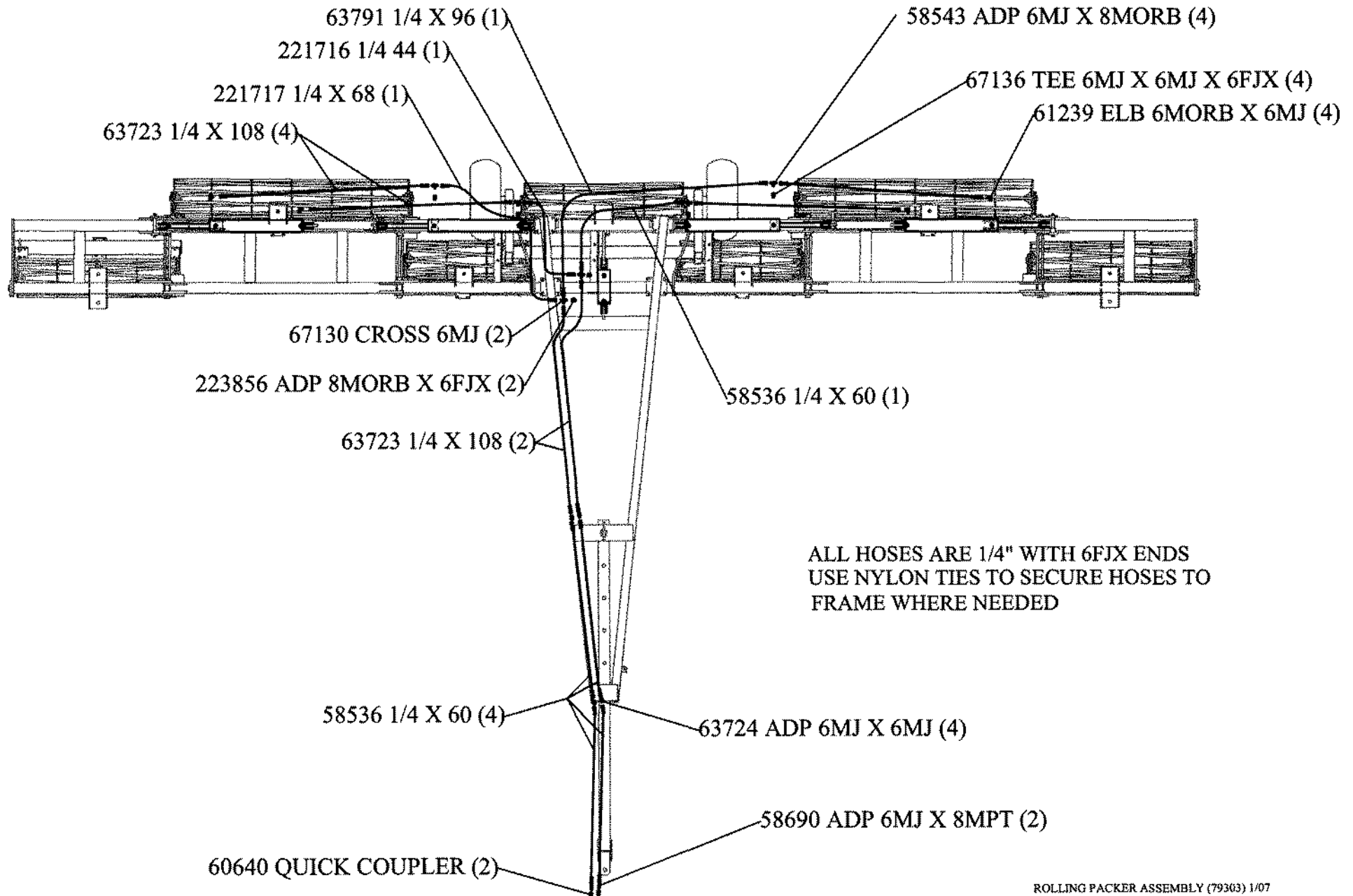

**ROLLING PACKER 41FT  
LIFT & WING FOLD HYDRAULICS**

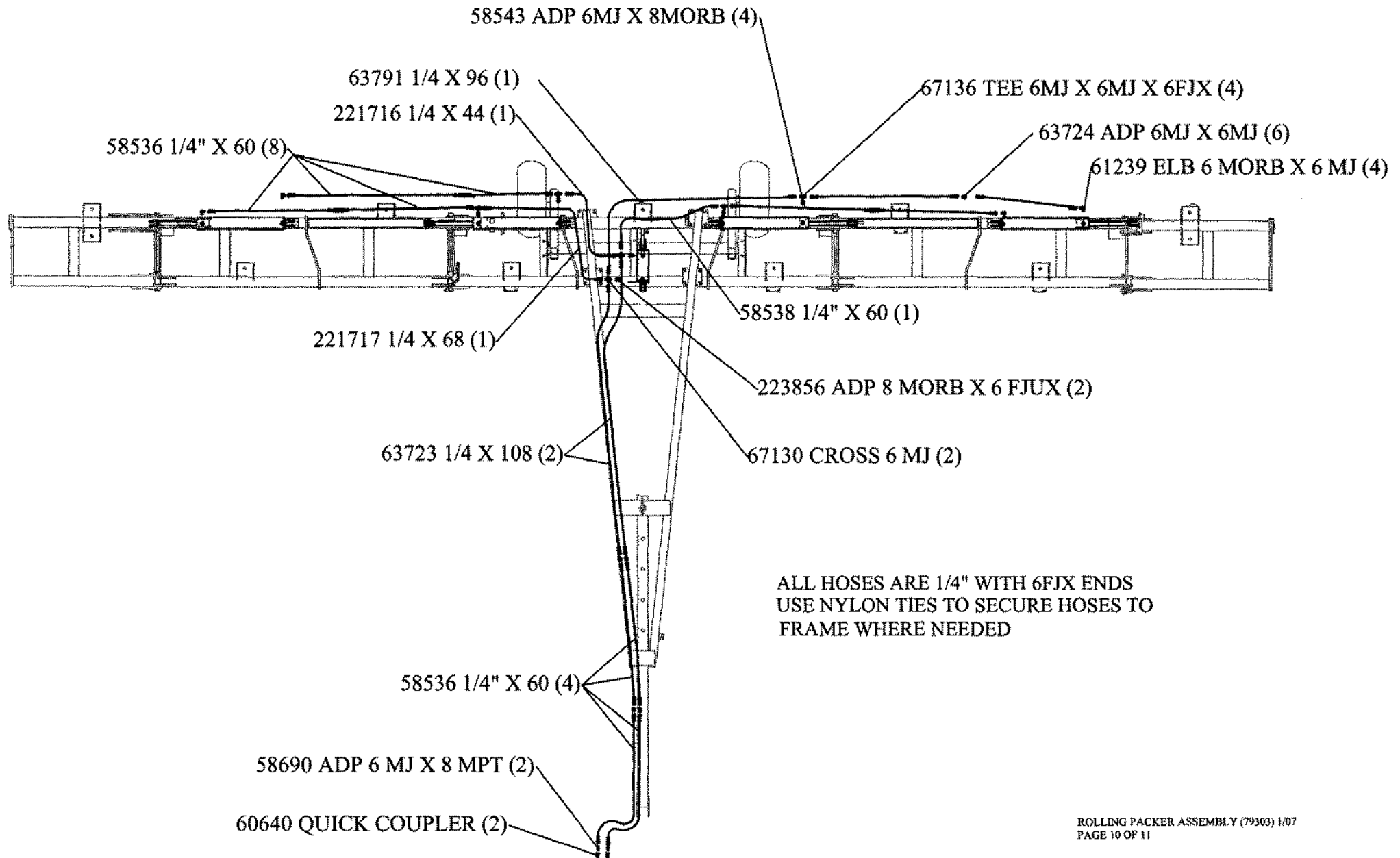





# ROLLING PACKER - 45.5FT THRU 51.5FT LIFT & WING FOLD HYDRAULICS

ALL HOSES ARE 1/4" WITH 6FJX ENDS  
USE NYLON TIES TO SECURE HOSES TO  
FRAME WHERE NEEDED

