



# OPERATOR'S MANUAL

# Quad<sup>X</sup>

## FIELD CULTIVATOR

Printed in USA (74231) JM-150 12/03

 **WIL-RICH**  
PO Box 1030  
Wahpeton, ND 58074  
PH (701) 642-2621  
Fax (701) 642-3372

## WARRANTY

The only warranty Wil-Rich gives and the only warranty the dealer is authorized to give is as follows:

We warrant products sold by us to be in accordance with our published specifications or those specifications agreed to by us in writing at time of sale. Our obligation and liability under this warranty is expressly limited to repairing, or replacing, at our option, within 12 months after date of retail delivery, any product not meeting the specifications. ***We make no other warranty, express or implied and make no warranty of merchantability or of fitness for any particular purpose.*** Our obligation under the warranty shall not include any transportation charges or costs or installation or any liability for direct, indirect or consequential damage or delay. If requested by us, products or parts for which a warranty claim is made are to be returned transportation prepaid to our factory. Any improper use, operation beyond rated capacity, substitution of parts not approved by us, or any alteration or repair by others in such manner as in our judgment affects the product materially and adversely shall void this warranty. ***No employee or representative is authorized to change this warranty in any way or grant any other warranty.***

Wil-Rich reserves the right to make improvement changes on any of our products without notice.

***When warranty limited or not applicable:*** Warranty on hoses, cylinders, hubs, spindles, engines, valves, pumps or other trade accessories are limited to the warranties made by the respective manufactures of these components. Rubber tires and tubes are warranted directly by the respective tire manufacturer only, and not by Wil-Rich.

Warranty does not apply to any machine or part which has been repaired or altered in any way so as in the our judgment to affect its reliability, or which has been subject to misuse, negligence or accident.

***A Warranty Validation and Delivery Report Form must be filled out and received by Wil-Rich to initiate the warranty coverage.***

### WARRANTY CLAIMS PROCEDURE

1. The warranty form must be returned to Wil-Rich within fifteen (15) working days from the repair date.
2. Parts returned to Wil-Rich without authorization will be refused. The parts must be retained at the dealership for ninety (90) days after the claim has been filed. If the Service Department would like to inspect the parts, a packing slip will be mailed to the dealer. The packing slip must be returned with the parts. The parts must be returned prepaid within thirty (30) days of receiving authorization. After the parts are inspected and warranty is verified, credit for the return freight will be issued to the dealer.
3. Parts that will be scrapped at the dealership will be inspected by a Wil-Rich Sales Representative, District Sales Manager or Service Representative within the ninety (90) day retaining period.

## TO THE OWNER

It is the responsibility of the user to read the Operator's Manual and comply with the safe and correct operating procedures as pertains to the operation, lubrication and maintenance of the product according to the information outlined in the Operator's Manual.

If this machine is used by an employee or is loaned or rented, make certain that the operator(s), prior to operating, is instructed in safe and proper use and reviews and understands the Operator's Manual.

The user is responsible for inspecting his/her machine and for having parts repaired or replaced when continued use of this product would cause damage or excessive wear to the other parts. The word NOTE is used to convey information that is out of context with the manual text; special information such as specifications, techniques, reference information of supplementary nature.

<b>WIL-RICH LLC</b>	
Wahpeton, ND	
Serial Number:	<input type="text"/>
	
Made in USA	

When in need of parts, always specify the model and serial number. Write this number in the space provided. The serial number plate is located on the main frame in the front left corner.

## **MODIFICATIONS**

It is the policy of Wil-Rich to improve its products whenever possible and practical to do so. We reserve the right to make changes, improvements and modifications at any time without incurring obligation to make such changes, improvements on any equipment sold previously.

## CONTENTS

TO THE OWNER .....	3
GENERAL INFORMATION .....	4
PERSONAL SAFETY .....	5
<b>OPERATION</b>	
SAFETY .....	5
PERSONAL SAFETY .....	6
HYDRAULIC, TRANSPORT SAFETY .....	7
TIRE & SAFETY DECALS .....	8
SIGN OFF SHEET .....	9
SAFETY DECAL PLACEMENTS .....	10-11
MAIN FRAME GAUGE WHEEL DAMPER .....	12
WING LIFT CIRCUITRY .....	13-14
MAIN FRAME ADJUSTMENTS .....	15
WING DEPTH ADJUSTMENT .....	16
DEPTH CONTROL CIRCUITRY .....	17
LEVELING & PRELIMINARY SETTINGS .....	17-18
FIELD SETTINGS .....	19-20
MAINTENANCE .....	20
CYLINDER SHAFTS .....	20
AXLE CAPS .....	21
HUB AND SPINDLE ASSEMBLIES .....	21
WALKING TANDEM ASSEMBLIES .....	21
HYDRAULICS .....	21
STORAGE .....	21
SHOVELS .....	22
SPIKES .....	22
SHOVEL EXTENSION .....	22
TROUBLE SHOOTING .....	23

# GENERAL INFORMATION

Remove all wires and/or banding material. The parts have been conveniently arranged on the pallet for ease of assembly.

NOTE: Always wear safety glasses or goggles and be careful when cutting wires and steel bands as they are under tension and will spring back when cut.

Wherever the terms "left" and "right" are used, it must be understood to mean from a position behind and facing the machine.

Lubricate all bearings and moving parts as you proceed and make sure they work freely.

Loosely install all bolts connecting mating parts before final tightening.

When tightening bolts, they must be torqued to the proper number of foot-pounds as indicated in the table unless specified. It is important that all bolts be kept tight.

On new machines, all nuts and bolts must be re-checked after a few hours of operation.

When replacing a bolt, use only a bolt of the same grade or higher. Except in shear bolt applications, where you must use the same grade bolt.

Bolts with no markings are grade 2



Grade 5 bolts furnished with the machine are identified by three radial lines on the head.

Grade 8 bolts furnished with the machine are identified by six radial lines on the head.

All U-bolts are grade 5.



**THIS SYMBOL USED TO CALL YOUR ATTENTION TO INSTRUCTIONS CONCERNING YOUR PERSONAL SAFETY. BE SURE TO OBSERVE AND FOLLOW THESE INSTRUCTIONS**

	GRADE 2		GRADE 5			GRADE 8	
							
TORQUE IN FOOT POUNDS							
BOLT DIA	3/8	1/2	5/8	3/4	7/8	1	
HEX HEAD	9/16	3/4	15/1	1-1/8	1-5/1	1-1/2	
UNC GR2	18	45	89	160	252	320	
UNC GR5	30	68	140	240	360	544	
UNC GR8	40	100	196	340	528	792	
UNF GR2	21	51	102	178	272	368	
UNF GR5	32	70	168	264	392	572	
UNF GR8	48	112	216	368	792	840	

TORQUE.EPS



**CAUTION**

- Just before and during operation be sure no one is on or around the implement.
- Before activating the hydraulic system, check hoses for proper connections.
- Before lowering the wings for the first time, make sure the entire system has been charged with oil.
- With wings down always install hydraulic cylinder channel lock(s) for transporting.

**FAILURE TO FOLLOW THESE INSTRUCTIONS MAY RESULT IN PERSONAL INJURY AND/OR EQUIPMENT DAMAGE.**

## **SAFETY**

YOU are responsible for SAFE operation and maintenance of your Wil-Rich Quad X Field cultivator. YOU must ensure that anyone who is going to operate, maintain or work around the QuadX be familiar with the operating and maintenance procedures and related safety information contained in this manual. This manual will take you step by step through your working day, alerts you to all good safety practices that should be adhered to while operating this equipment.



**Remember, YOU are the key to safety. Good safety practices not only protect you but also the people around you. Make these practices a working part of your safety program. Be certain that EVERYONE operating this equipment is familiar with the recommended operating and maintenance procedures and follows all safety precautions. Most accidents can be prevented. Do not risk injury or death by ignoring good safety practices.**

Quad X owners must give operating instructions to operators and employees before allowing them to operate the field cultivator, and at least annually thereafter per OSHA regulation 1928.57.

The most important safety device on this equipment is a safe operator. It is the operator's responsibility to read and understand ALL Safety and Operating instructions in the manual and to follow them. All accidents can be avoided.

A person who has not read and understood all operating and safety instructions is not qualified to operate the machine. An untrained operator exposes themselves and bystanders to possible serious injury or death.

Do not modify the equipment in any way. Unauthorized modifications may impair the function and/or safety and could affect the life of the equipment.

Think SAFETY! Work SAFELY!

### **General Safety**

Read and understand the operator's manual and all safety signs before operating, maintaining or adjusting the Quad X.

Install and properly secure all shields and guards before operating.

Have a first-aid kit available for use should the need arise and know how to use it.

Have a fire extinguisher available for use should the need arise and know how to use it.

Clear the area of people and remove foreign objects from the machine before starting and operating.

Always wear relatively tight and belted clothing to avoid entanglement in moving parts. Wear sturdy, rough-soled work shoes and protective equipment for eyes, hair, hands, hearing and head.

Do not allow riders.

Wear suitable ear protection for prolonged exposure to excessive noise.

Stop tractor engine, place all controls in neutral, set park brake, remove ignition key and wait for all moving parts to stop before servicing, adjusting, repairing or unplugging.

Review safety related items with all operators annually.

# PERSONAL SAFETY IS IMPORTANT!

ALL PERSONNEL INVOLVED WITH THE ASSEMBLY AND/OR OPERATION OF THIS EQUIPMENT MUST BE INFORMED OF PROPER SAFETY PROCEDURES. OPERATOR'S/ ASSEMBLY MANUALS PROVIDE THE NECESSARY INFORMATION. IF THE MANUAL IS LOST FOR A PARTICULAR IMPLEMENT, ORDER A REPLACEMENT AT ONCE. OPERATOR'S AND ASSEMBLY MANUALS ARE AVAILABLE AT NO CHARGE UPON REQUEST.

This Safety Alert symbol means **ATTENTION! BECOME ALERT YOUR SAFETY IS INVOLVED!**

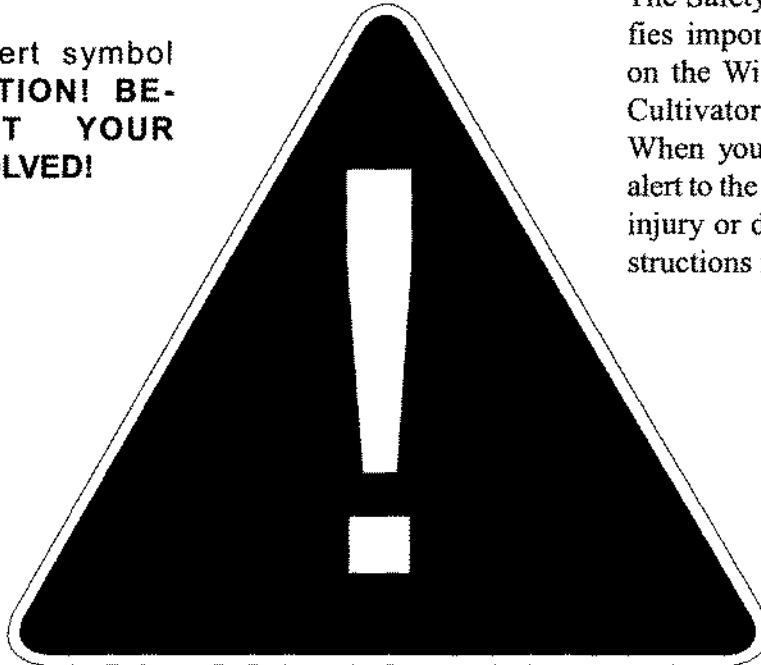

The Safety Alert symbol identifies important safety messages on the Wil-Rich Quad X Field Cultivator and in this manual. When you see this symbol, be alert to the possibility of personal injury or death. Follow the instructions in the safety message.

Why is SAFETY important to you?

## 3 Big Reasons

**Accidents Disable and Kill**  
**Accidents Cost**  
**Accidents Can Be Avoided**

### SIGNAL WORDS:

Note the use of the signal words **DANGER**, **WARNING** and **CAUTION** with the safety messages. The appropriate signal word for each message has been selected using the following guidelines:

### DANGER

An immediate and specific hazard which **WILL** result in severe personal injury or death if the proper precautions are not taken.

### WARNING

A specific hazard or unsafe practice which **COULD** result in severe personal injury or death if the proper precautions are not taken

### CAUTION

Unsafe practices which **COULD** result in personal injury if proper practices are not taken, or as a reminder of good safety practices.

ADDRESS INQUIRIES TO: WIL-RICH PO BOX 1030  
WAHPETON, ND 58074  
PH (701) 642-2621 FAX (701) 642-3372

## HYDRAULIC SAFETY

Always place all tractor hydraulic controls in neutral before dismounting.

Make sure that all components in the hydraulic system are kept in good condition and are clean.

Relieve pressure before working on hydraulic system.

Replace any worn, cut, abraded, flattened or crimped hoses and metal lines.



Do not attempt any makeshift repairs to the hydraulic lines, fittings or hoses by using tape, clamps or cements. The hydraulic system operates under extremely high-pressure. Such repairs will fail suddenly and create a hazardous and unsafe condition.

Wear proper hand and eye protection when searching for high pressure leaks. Use a piece of cardboard as a backstop instead of hands to isolate and identify a leak.

If injured by a concentrated high-pressure stream of hydraulic fluid, seek medical attention immediately. Serious infection or toxic reaction can develop from hydraulic fluid piercing the skin surface.

Before applying pressure to the system, make sure all components are tight and that lines, hoses and couplings are not damaged.

Think SAFETY! Work SAFELY!

 <b>WARNING</b>	
	
<b>HIGH PRESSURE FLUID HAZARD</b> To prevent serious injury or death:	
<ul style="list-style-type: none"><li>● Relieve pressure on system before repairing or adjusting or disconnecting.</li><li>● Wear proper hand and eye protection when searching for leaks. Use wood or cardboard instead of hands.</li><li>● Keep all components in good repair.</li></ul>	
60711	

## TRANSPORT SAFETY

Read and understand ALL the information in the Operator's Manual regarding procedures and SAFETY when moving QuadX in the field/yard or on the road.

Check with local authorities regarding transportation on public roads. Obey all applicable laws and regulations.

Always travel at a safe speed. Use caution when making corners or meeting traffic.

Make sure SMV (Slow Moving Vehicle) emblem and all lights and reflectors that are required by the local highway and transport authorities are in place, are clean and can be seen clearly by all overtaking and oncoming traffic

Use a drawbar pin with provisions for a mechanical retainer.

Attach a safety chain before moving.

Keep to the right and yield the right-of-way to allow faster traffic to pass. Drive on the road shoulder, if permitted by law.

Always use hazard warning flashers on tractor when transporting unless prohibited by law.

Do not allow riders.

Do not exceed 20 m.p.h. during transport.

## **STORAGE SAFETY**

Store unit in an area away from human activity.

Do not permit children to play around the stored unit.

Store in a dry, level area. Support the base with planks if required.

## **TIRE SAFETY**

Failure to follow proper procedures when mounting a tire on a wheel or rim can produce an explosion which may result in serious injury or death.

Do not attempt to mount a tire unless you have the proper equipment and experience to do the job.

Have a qualified tire dealer or repair service perform required tire maintenance.

## **SAFETY DECALS**

Keep safety decals and signs clean and legible at all times.

Replace safety decals and signs that are missing or have become illegible.

Replaced parts that displayed a safety sign should also display the current sign.

Safety decals or signs are available from your Dealer Parts Department.

How to install Safety Decals:

Be sure that the installation area is clean and dry.

Decide on the exact position before you remove the backing paper.

Remove the smallest portion of the split backing paper.

Align the decal over the specified area and carefully press the small portion with the exposed sticky backing in place.

Slowly peel back the remaining paper and carefully smooth the remaining portion of the decal in place.

Small air pockets can be pierced with a pin and smoothed out using the piece of decal backing paper.





# SAFETY DECALS

22371 RED REFLECTOR



2012 INTEGRAL RESTRICTOR DECAL

22372 AMBER REFLECTOR



49163 WING LOCK DANGER DECAL

WINGS UP	WINGS DOWN	MAIN UP	MAIN DOWN
WINGS UP	WINGS DOWN	MAIN UP	MAIN DOWN
WINGS UP	WINGS DOWN	MAIN UP	MAIN DOWN
WINGS UP	WINGS DOWN	MAIN UP	MAIN DOWN
WINGS UP	WINGS DOWN	MAIN UP	MAIN DOWN
WINGS UP	WINGS DOWN	MAIN UP	MAIN DOWN

- 54900 WINGS UP DECAL
- 54901 WINGS DOWN DECAL
- 54902 MAIN UP DECAL
- 54903 MAIN DOWN DECAL

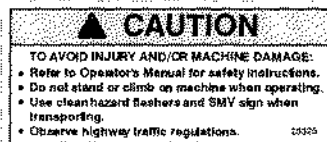

23325 CAUTION DECAL - READ

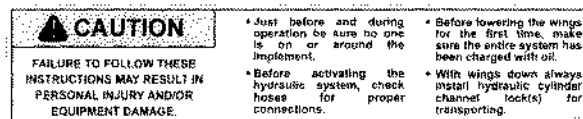

49165 CAUTION DECAL

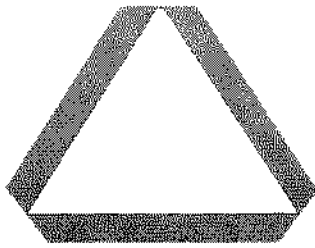

41345 SMV KIT

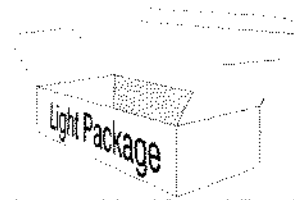

64594 CLEARANCE LIGHT PACKAGE

	<b>⚠ DANGER</b> <b>STAND CLEAR AT ALL TIMES.</b>	<ul style="list-style-type: none"> <li>• Never walk or stand in the path of the wings.</li> <li>• Completely lower the wings before performing service or adjustments.</li> <li>• Failure to do so will result in serious injury or death.</li> </ul>	<b>ASSEMBLE SO DECAL IS READ FROM THE IMPLEMENT REAR.</b>
	<p>41508 WING LOCK DANGER DECAL</p>		

<b>⚠ CAUTION</b> <b>FAILURE TO FOLLOW THESE INSTRUCTIONS MAY RESULT IN PERSONAL INJURY AND/OR EQUIPMENT DAMAGE.</b>	<ul style="list-style-type: none"> <li>• Just before and during operation be sure no one is on or around the implement.</li> <li>• Before activating the hydraulic system, check hoses for proper connections.</li> <li>• Before lowering the wings for the first time, make sure the entire system has been charged with oil.</li> <li>• With wings down always install hydraulic cylinder lock(s) for transporting.</li> </ul>
--	--

53334 CAUTION DECAL

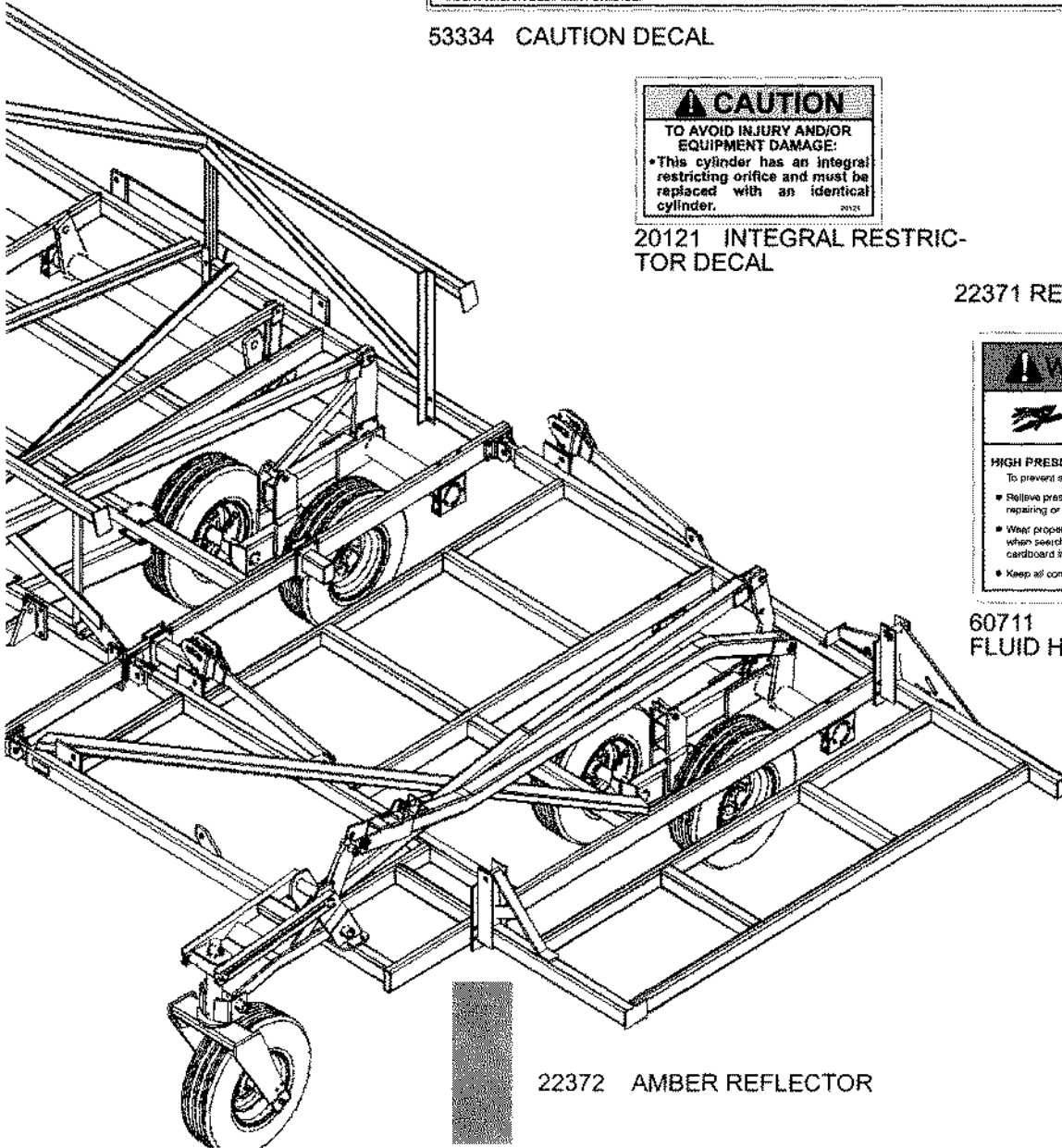

<b>⚠ CAUTION</b> <b>TO AVOID INJURY AND/OR EQUIPMENT DAMAGE:</b> <ul style="list-style-type: none"> <li>• This cylinder has an integral restricting orifice and must be replaced with an identical cylinder.</li> </ul>
---

20121 INTEGRAL RESTRICTOR DECAL



22371 RED REFLECTOR

<b>⚠ WARNING</b> 
<b>HIGH PRESSURE FLUID HAZARD</b> To prevent serious injury or death: <ul style="list-style-type: none"> <li>• Relieve pressure on system before repairing or adjusting or disconnecting.</li> <li>• Wear proper hand and eye protection when searching for leaks. Use wood or cardboard instead of hands.</li> <li>• Keep all components in good repair.</li> </ul>

60711 HIGH PRESSURE FLUID HAZARD



22372 AMBER REFLECTOR

# MAIN FRAME GAUGE WHEEL DAMPER

The main frame front gauge wheels are equipped with a spring loaded damper to hold the wheel straight in transport. When transporting units with heavy rear attachments the unit may not have sufficient weight on the front gauge wheels to prevent oscillation. The spring damper will prevent this oscillation and allow transport at normal speeds. **IMPORTANT - This spring damper will not function unless the unit is in the fully raised position. This means the main lift cylinders must be fully extended for dampers to work.** Failure to raise the unit fully can cause transport stability problems. (See Fig. 1)

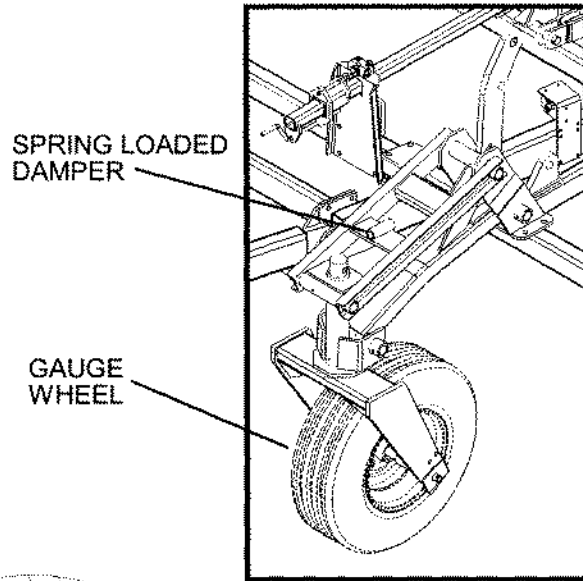
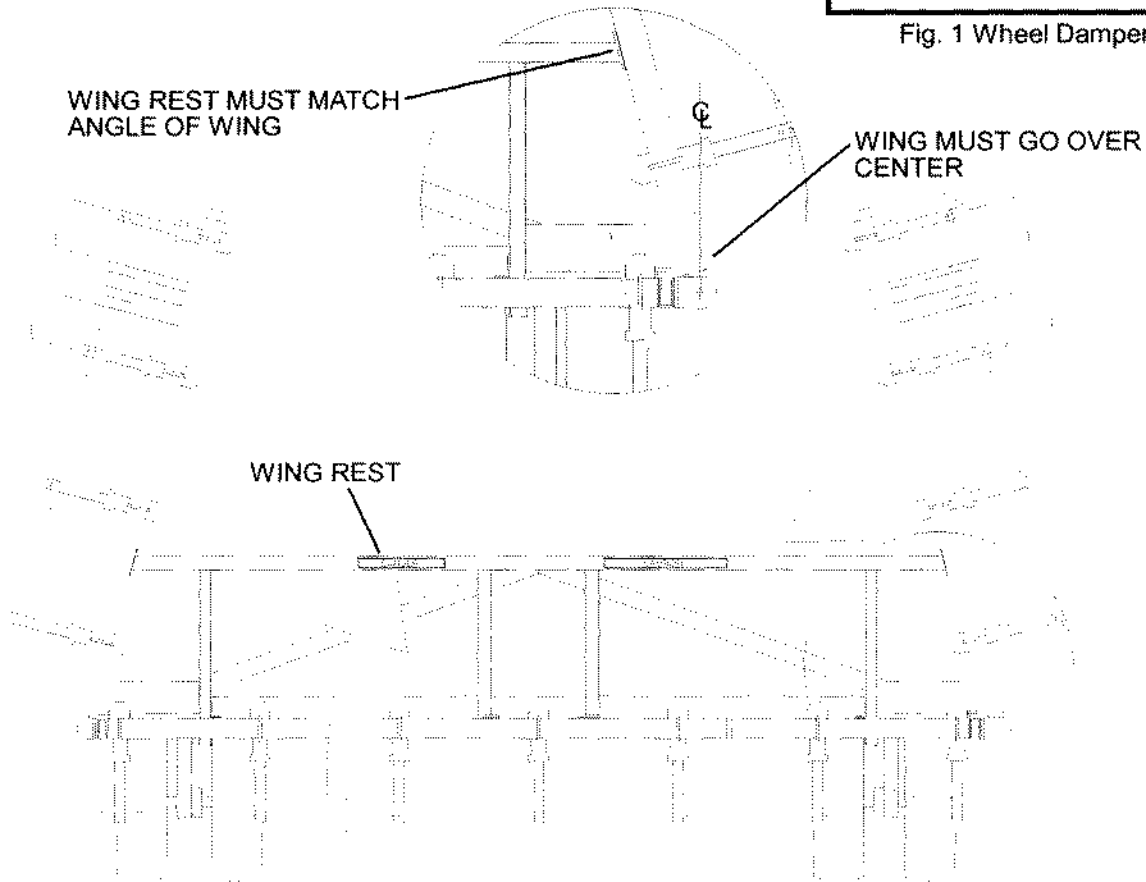

Fig. 1 Wheel Damper



**Note: Assemble so decal is read from the implement rear.**

Fig. 2 Wing Rest

	<p><b>⚠ DANGER</b> STAND CLEAR AT ALL TIMES:</p>	<ul style="list-style-type: none"> <li>• Never walk or stand in the path of the wings.</li> </ul>	<ul style="list-style-type: none"> <li>• Completely lower the wings before performing service or adjustments.</li> </ul>	<ul style="list-style-type: none"> <li>• Failure to do so will result in serious injury or death.</li> </ul>	<p>ASSEMBLE SO DECAL IS READ FROM THE IMPLEMENT REAR.</p>
--	--	---	--	--	---

# WING LIFT CIRCUITRY

Wing equipped Wil-Rich field cultivators have hydraulic wing lift cylinders to fold the implement for road transport.

Wing lift cylinders are equipped with an integral restrictor on the rod end cylinder port (see fig. 3.). This allows the wings to lower at a slower rate and prevents the wings from falling to fast should there be some type of hydraulic failure.

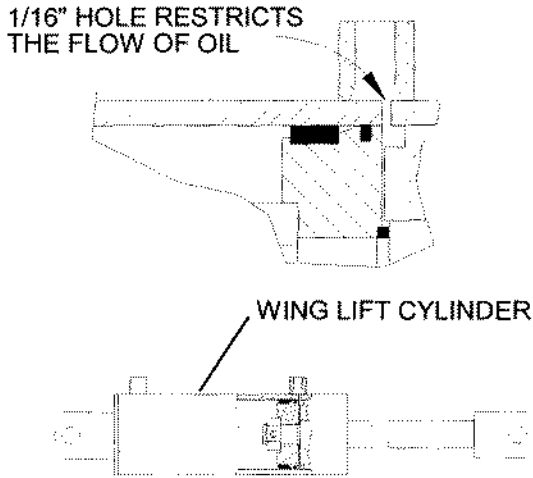

Fig. 3 Wing Lift Cylinder

Fig. 4 shows a simple two (2) cylinder circuit used to fold a pair of wings. This system is used on Wil-Rich cultivators with a single pair of folding cylinders.

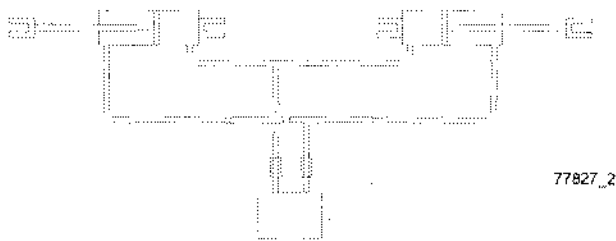

Fig. 4 Two Cylinder Wing Lift Circuit

When lowering the wings, hold the tractor control lever until all cylinders are completely extended. Fully extending the cylinders allows the wings to flex properly in the field.

When raising the wings be sure the wing rest is properly positioned to allow the wings to fold. Fold the main wings until they contact the wing rest.

Fig.5 Shows a simple four (4) cylinder circuit used to fold a pair of wings. This system is used on Wil-Rich Quad X field cultivators with a single pair of 9'4" or 11'8" folding wings.

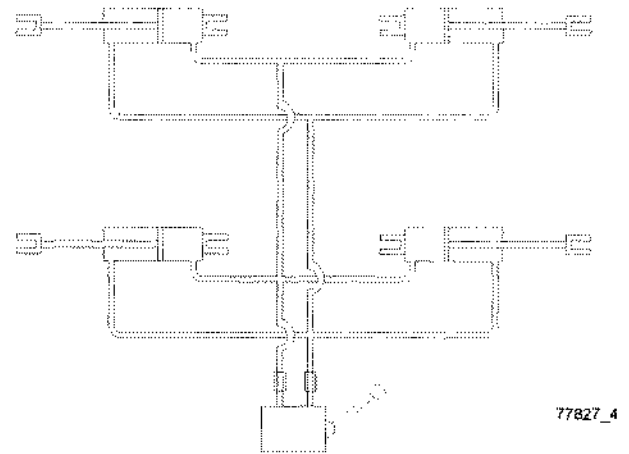

Fig. 5 Four Cylinder Wing Lift Circuit

When lowering the wings, hold the tractor control lever until all cylinders are completely extended. Fully extending the cylinders allows the wings to flex properly in the field.

When raising the wings be sure the wing rest is properly positioned to allow the wings to fold. Fold the main wings until they contact the wing rest.

Units equipped with a folding outer stub wing require a sequencing valve in the hydraulic fold circuitry (Fig. 6).

The valve is connected as shown in the hydraulic assembly instructions. Correct assembly is critical for proper operation.

The sequencing valve is intended to retard the unfolding of the outer wings until the inner wings have been completely unfolded.

The sequencing valve should not effect the folding of the inner and outer wings. If the outer wings start to unfold before the inner wings have completely folded the valve needs to be adjusted. Loosen the valve adjustment locking nut on the valve and using a allen wrench, turn the adjust bolt in or clockwise. This will raise the pressure needed to sequence the valve. Readjust valve as needed to ensure complete unfolding of the inner wing before the outer wings unfold. Secure setting with the lock nut.

Hydraulic system pressure and volume will vary between tractors and may require occasional re-adjustment of this valve.

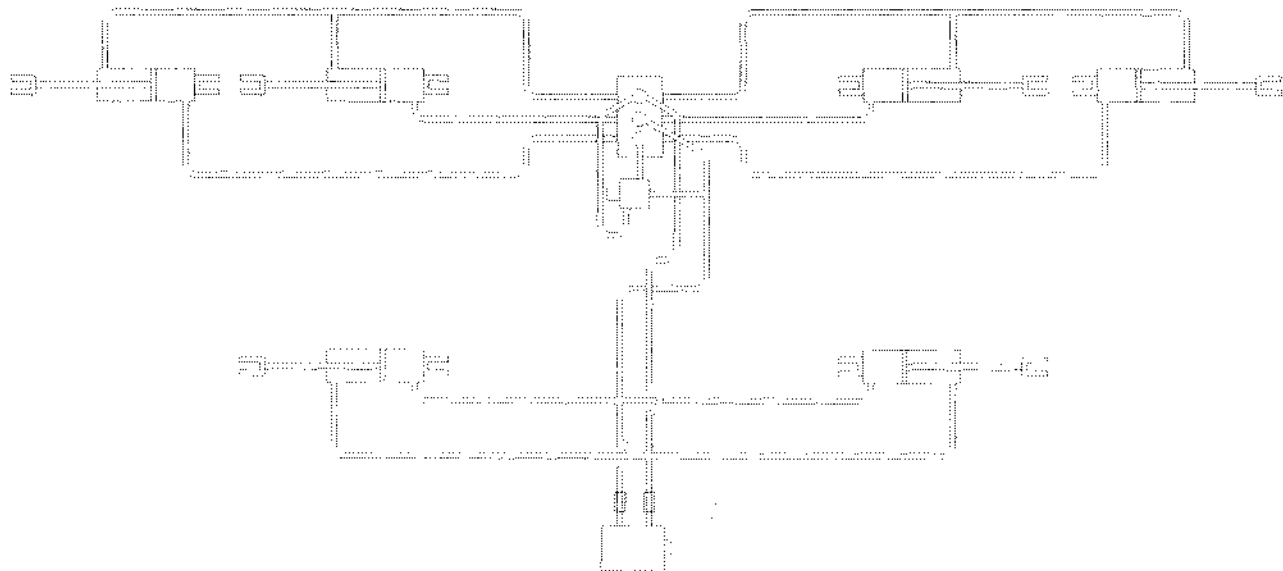

Fig. 6 4 Cylinder Wing Lift Circuitry w/2 Cylinders  
Outer Wing Circuitry

78358

# MAIN FRAME DEPTH ADJUSTMENT

The main frame depth on the WIL-RICH QuadX field cultivator is controlled by a pair of 12.6" stroke bypass cylinders. These cylinders are located at the front corners of the unit, above the main frame lift axles. The cylinders are tied to the main axle through the main mast tube. The main mast tube is adjustable and pinned into the main frame gauge wheel. See Fig 7.

**Note: The main and wing lift cylinders need to be positioned with the rod end of the cylinder attached to the main frame gauge wheel as shown.**

The top bypass cylinders have adjustable mechanical screw collars. These screw collars are rotated on the cylinder rod to vary the retracted length of the cylinder, providing the means to adjust the working depth of the unit.

ROTATION THIS DIRECTION,  
LOWERS WORKING HEIGHT

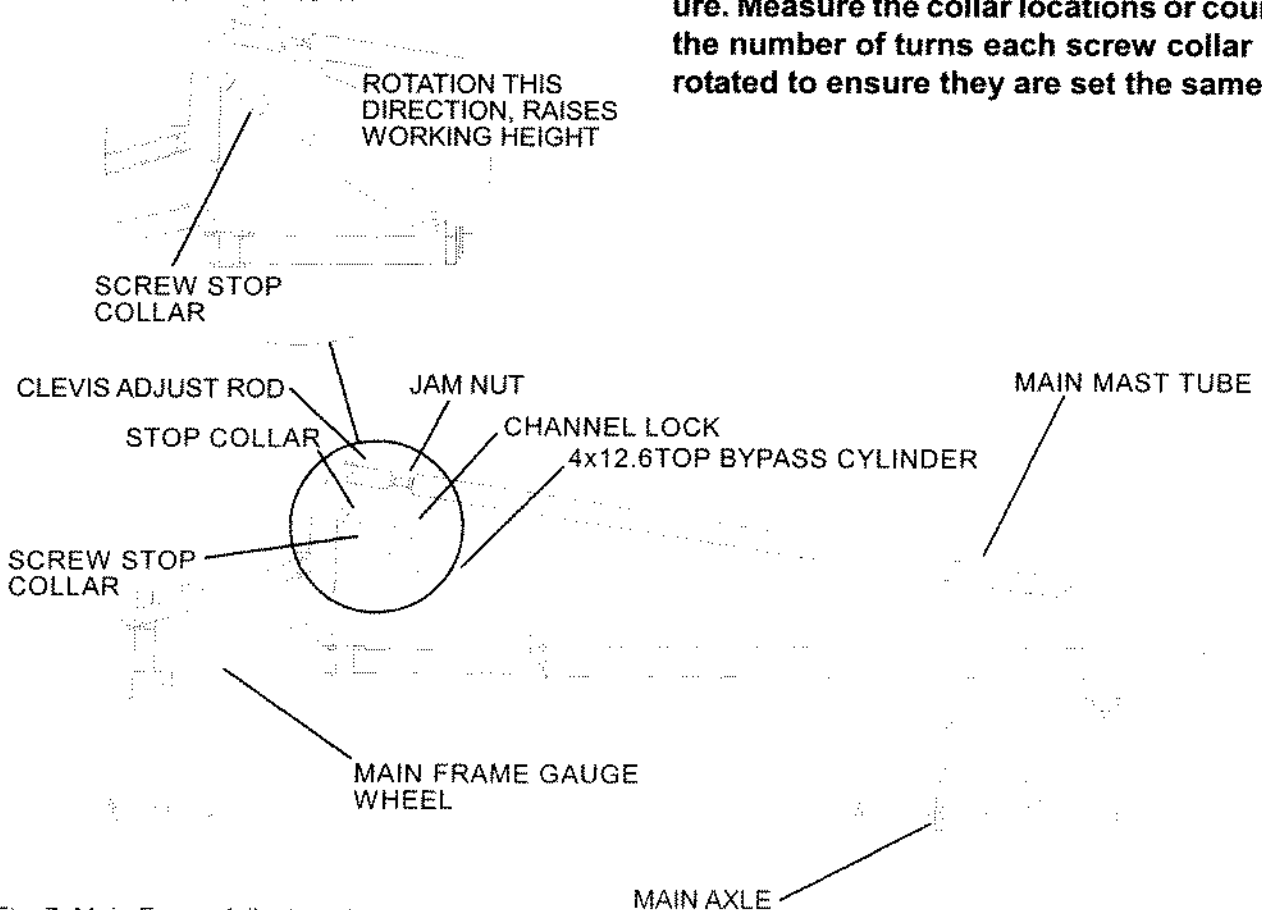

Fig. 7 Main Frame Adjustment

The main frame depth is mechanically set by turning the screw collar "TOWARD THE CLEVIS" on the cylinder rod to increase (deeper) the working depth or "AWAY FROM THE CLEVIS" on the cylinder rod to decrease (shallower) the working depth. An add-on stop collar is provided for situations where the screw stop collar does not allow a shallow enough setting.

**NOTE: Proper field operation is dependent upon the screw collars of the main frame lift cylinders being first to contact the mechanical stops. If a wing cylinder screw stop collars contacts first the leveling function of the system will not operate correctly.**

**NOTE: The cylinder screw stop collars on the main frame depth control cylinders must be set equally – failure to do so can twist the main axle and cause axle failure. Measure the collar locations or count the number of turns each screw collar is rotated to ensure they are set the same.**

## WING DEPTH ADJUSTMENT

The operational depth of the wing is set by adjusting the slave cylinder located at the rear wing axle and adjuster rod (9.5) at the front of the wing (Fig. 8).

The 10.8" stroke cylinders are connected in series with the main frame top by pass cylinders. See Depth Control Circuitry, Fig. 10.

By adjusting at these two locations the wing can be leveled from front to rear and raised or lowered relative to the main frame.

For shallow depth cultivation stop collars may be required on both the main and wing lift cylinders. Each cylinder box should contain a single stop collar. Additional stop collars should be available from your dealer.

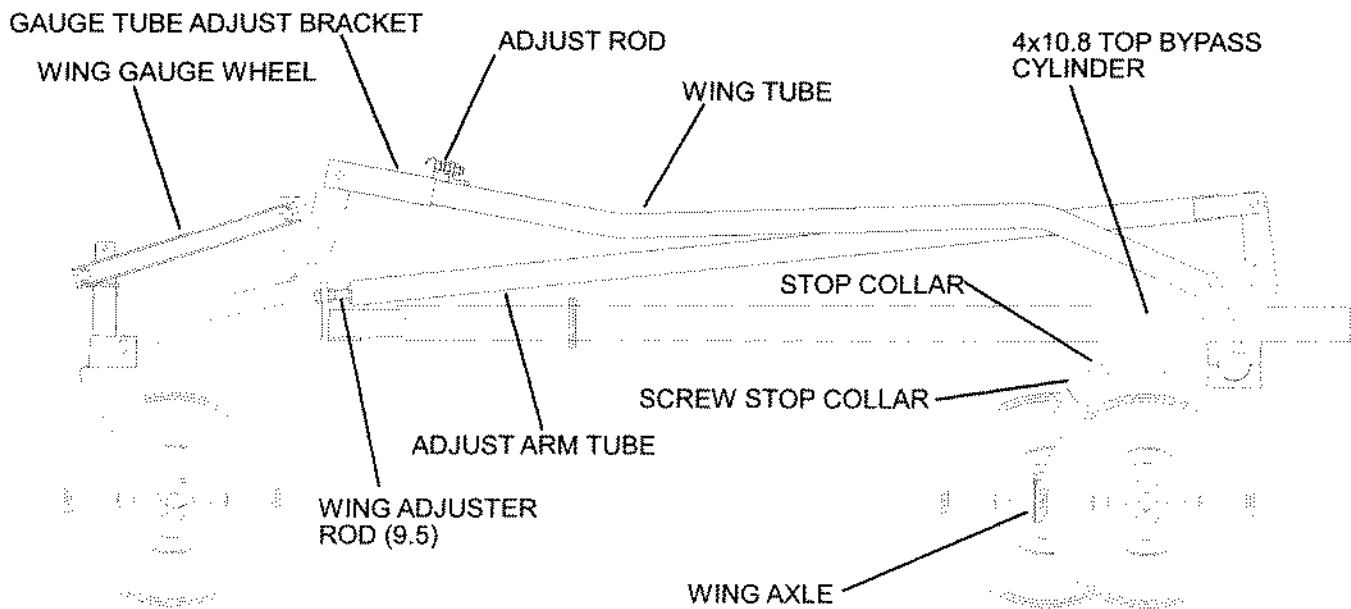

Fig. 8 Wing Frame Adjustment



## DEPTH CONTROL CIRCUITRY

The depth control cylinders are hooked in series. Each cylinder is a top bypass cylinder and when fully extended will pass oil by the piston into the next cylinder charging the system.

Top bypass cylinders will bypass oil when the cylinder is fully extended. This bypass condition will exist when the implement is raised to maximum ground clearance. At this time oil will pass through a 1/16" dia hole and go on to the next cylinder. See Fig. 9 & 10.

**Note: This system requires periodic raising of the unit and holding of the tractor valve to expel air or contaminants.**

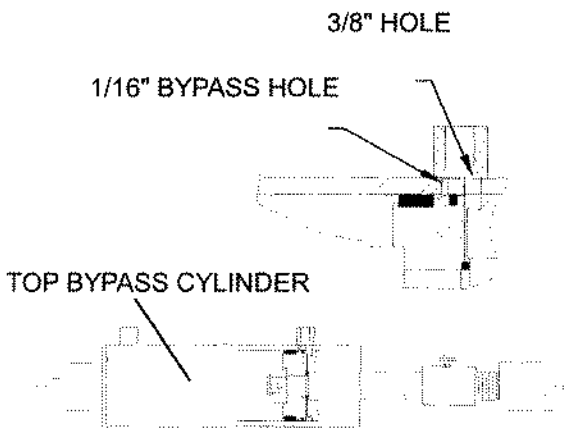

Fig. 9

77646

**Note: To synchronize or re-synchronize the bypass system, the tractor control valve must be held in the raised position until the entire implement is raised and any air that may be in the lines has been expelled.**

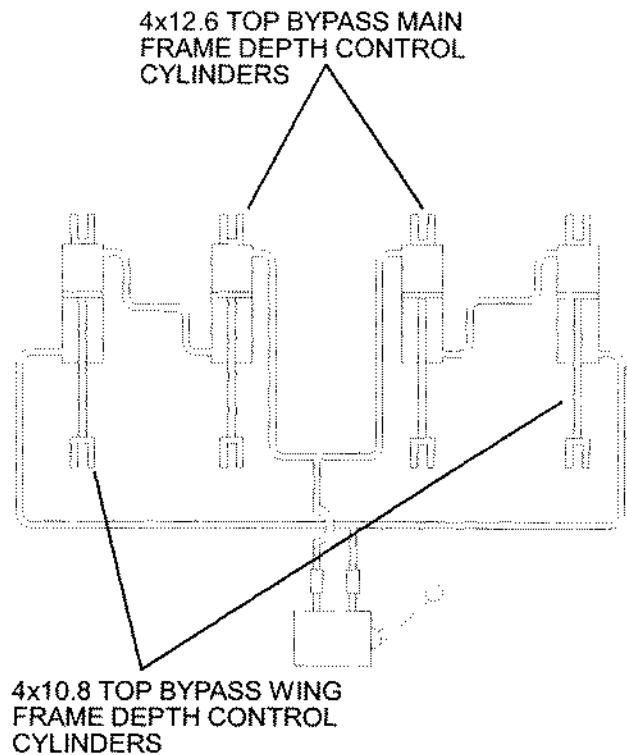

Fig. 10 Lift Hydraulic Circuit

## LEVELING

The operational leveling of the field cultivator must be done in a level area of the field. Final front to rear and side to side leveling is done at working depth. Preliminary setting can be completed in the yard to speed up the field setting operation.

The front to rear level of the main frame is controlled by the main axle lift wheels and the main frame gauge wheels. The front to rear level of the wing is controlled by the wing axle lift wheels and the hydraulic front gauge wheel. Both the main frame and the wings will need to be adjusted correctly for proper operation.

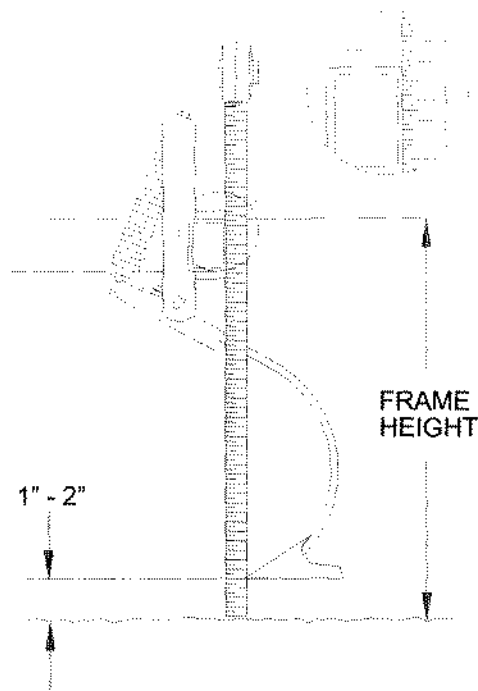

Fig. 11 Shank Settings

## PRELIMINARY SETTINGS

Proper preliminary and field settings will require the use of a measuring device. Once the unit has been properly assembled and hitched to the tractor, *make certain the hydraulic system as been charged.*

Position the unit on a level area of ground and unfold the wings, *checking to ensure that there are no people or obstruction in the path of the wings.*

**NOTE: Cycle the main lift hydraulic system a number of times to remove air from the circuit. Holding the hydraulic lever in the "RAISE" position for a 1-2 minute period should remove unwanted air.**

Remove the stop collars from all cylinders and turn the screw stop collars up to the clevis end of the cylinders. Lower the unit so that the main frame front shovels are 1"-2" above the ground. Measure the frame height from the ground to the top of the front main frame tube. Compare this to the distance from the ground to the top of the rear tube on the rear bar of the main frame. See Fig 11.

## Level Main Frame - Front to Rear

Front to rear main frame level is adjusted by changing the setting of the clevis adjust rod above the main lift cylinder. See Fig 7. Loosen the jam nut and turn the threaded clevis adjust rod out of the main mast tube. By increasing the length of the mast tube you will lower the rear of the main frame. To raise the rear of the main frame the main mast tube will need to be shortened, turn the clevis adjust rod into the mast tube. **NOTE: If the clevis adjust rod is difficult to turn, lower the unit to the ground to remove the weight from the linkage.**

Repeat this procedure on both sides of the main frame, checking to ensure that the main adjust tubes are the same relative length. Retighten the jam nuts on the clevis adjust rods when the final settings are reached.

## Level Wing Frame – Front to Rear & Side to Side

Depending on the size of the main wing and type or weight of any rear attachments you will need to adjust the front to rear level of the wings. In some situations either the front gauge wheel or rear axle can hold the wing at a set depth. For setting purposes, loosen the nuts at the gage tube adjust bracket at the front of the wing tube and the jam nut on the adjuster rod. See Fig 8. Measure the distance from the ground to top of the rear tube at the outer rear corner of the wing. Compare this to the distance set at the rear of the main frame. If the rear of the wing needs to be raised, turn the adjust rod (9.5) into the wing tube. If the rear of the wing needs to be lowered, turn the adjust rod out. When the rear distance on the wing matches the main frame you can tighten the adjuster rod nut.

Measure the distance from the ground to the top of the front tube at the outer front corner of the wing. Again compare this to the distance measurement of the front tube of the main frame. To raise the front of the wing, lengthen the adjust rod at the gage tube adjust bracket. This will increase the length of the wing tube/adjust bracket assembly and raise the front corner of the wing. Conversely, shorten or decrease the adjust rod setting to lower the front corner of the wing.

Follow the same process to adjust the other wing. This procedure should set both the front to rear and side to side level of the unit.

## FIELD SETTINGS

Even if the unit has been leveled in the yard it should never be assumed that the unit would operate level in the field. Changing field conditions, loading of the shanks and attachments will impact the functional level and working of the unit.

Move to the field and stop the unit in a level area. Unfold the wings, making certain that there is adequate room, with no person or obstruction in the wing fold region. Activate the main lift hydraulics and remove the transport channel locks from the main frame lift cylinders. Make a visual inspection of the unit to ensure that all hardware is tight, hoses are clear and that the unit is ready for field operation. Stop collars should have been removed for yard adjustment and all screw stop collars should be turned to the clevis end. Cycle the hydraulics a couple of times to purge any air from the system.

Move forward in the field at a moderate speed and lower the unit into the ground. Stop and measure the depth of operation of the shanks at the front of the main frame. By use of the screw stop and stop collars on the main frame lift cylinder set the desired depth of the unit. You may need to set a depth, pull forward through the field, stop, check and adjust the depth a number of times. Once the front has been set, measure the rear shank depth and adjust the clevis adjust rod on the main mast tubes to raise or lower the rear of the unit. Once the main frame is level tighten all jam nuts or screw stop thumbscrews to hold the position.

Raise the unit out of the ground, cycle the main lift hydraulics and drop the unit back to operating depth. Move to the rear corner of the wing and check the operating depth relative to the main frame depth. If the wing needs to be raised you need to shorten the adjust arm by turning the adjuster rod (9.5) into the adjust arm tube. To lower the wing, lengthen the adjust tube by adjusting the rod out.

Move to the front corner of the wing and check the operating depth relative to the main frame. If the front of the wing needs to be raised, lengthen the wing tube by changing the adjust rod at the gage tube adjust bracket. To lower the front of the wing, shorten the wing tube at the gauge tube adjust bracket.

Follow the same process to adjust the opposite wing. Recheck all depth settings and tighten all adjustment nuts. As conditions change the level of the unit may need to be altered as required.

**NOTE: The depth of the unit is controlled by the screw stop settings of the main frame lift cylinders. Depth should be reached when the main lift cylinder screw collars contact the cylinder end plate. Follow the field setting instructions noted above to set operational depth and level. Once the main frame screw collars are set you can turn the screw collars on the wing cylinders down to just contact the cylinder end plates. This provides a backup to maintain a consistent unit depth if seals should fail. Do not use the wing cylinder screw stop collars to control the unit depth. Level and wing depth adjustments should be made with the various adjustment rods.**

**On units equipped with single point depth control the setting process is the same. Instead of setting the main frame operating depth with the main lift cylinder screw stop and collars the depth is set with the single point. Again, make certain the wing lift cylinders stop collars are not contacting the end plate before the single point depth stop is fully depressed.**

Each shank comes fully assembled from the factory. Install the shanks in their proper location and securely tighten u-bolt nuts.

It is recommended that a 47° sweep be used on all shank assemblies.

**Note: Spring adjust bolt should be tightened just enough to crack the paint between spring coils.**

The mounting bolts, U-bolts and shank bolts must all be checked after a few days work and kept tight.

The mounting bolts must not be overtightened, but kept tight enough to allow free movement of the shank.

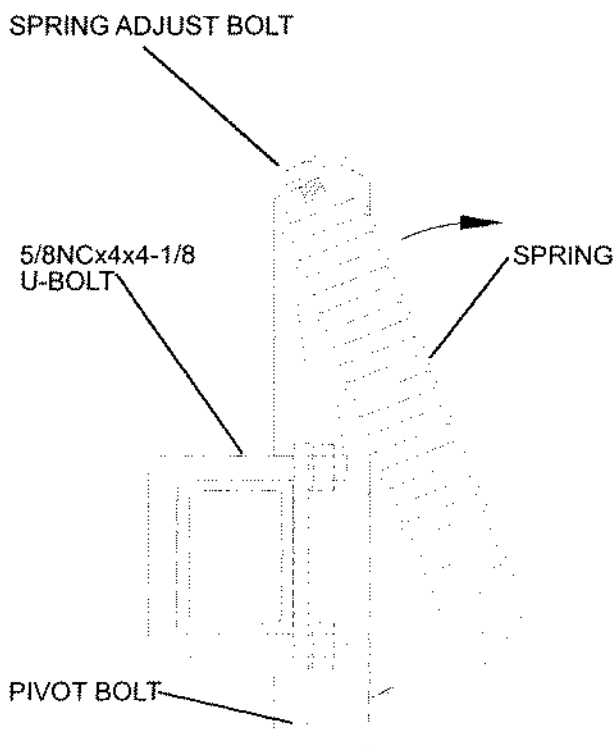

77828

Fig. 12 Wheel Damper

Wil-Rich field cultivators are also available with twin spring or hi-torque shank assemblies. The twin spring shank assemblies are recommended for heavy duty use.

**Note: Be sure to maintain adequate tire/shovel clearance on shanks located in or around the wheel well when machine is fully raised or lowered.**

## MAINTENANCE

Periodic checks must be made to assure that all nuts and bolts remain securely tightened. Loose hardware is easily bent or lost and can cause excessive wear on parts. Replace any bent or broken bolts as soon as they are discovered.

Clean off any dirt or grease that may accumulate on moving parts at regular intervals. This will prevent any abrasive action which could cause excess or premature wear. Thoroughly inspect the implement for loose or broken parts and adjust or replace as necessary.

It is important that the implement be regularly lubricated as recommended to obtain the most efficient operation. Proper lubrication helps prevent down time due to excessive wear and increase machine life.

### **CYLINDER SHAFTS**

If the cylinder shafts are left exposed for any extended period of time, they should be coated with grease to protect them from rust and corrosion.

## AXLE CAPS

All axle caps must be greased once a day with a good quality grease. Lower machine onto the shovel points to relieve pressure on the caps which will make greasing easier.

## HUB AND SPINDLE ASSEMBLIES

Each hub and spindle assembly comes with a grease fitting installed in the hub. These must be greased once a week during steady usage. Caution - do not over grease

Clean and repack hub and spindle bearings once each season.

Tighten spindle nut so that there is a slight drag on the wheel when turned by hand.

## WALKING TANDEM ASSEMBLIES

Periodically check each walking tandem assembly for looseness and tighten spindle nut if the bearings show any evidence of side play.

Clean and repack walking tandem assemblies once each season.

The spindle nut should be tightened to allow a heavy drag when assembly is rotated by hand.

## HYDRAULICS

Inspect all hydraulic hoses and fittings for cracks and abrasion at least once a year. Tighten or replace as needed.

When connecting the hoses to the cylinders, tubing, or fittings; always use one wrench to prevent the hose from twisting and another wrench to tighten the union. Excessive twisting will shorten the hose life.

Do not overtighten hydraulic fittings, excessive torque may cause them to crack.

Care must be taken to prevent twisting when tightening hose connections. Straighten any hose that appears twisted immediately. A twisted hose can burst under operating pressure.

## STORAGE

**Note: if possible store your cultivator inside.**

At the end of a season, clean the implement thoroughly to remove any trash, soil or dirty grease which could hold moisture and cause premature rusting. Repaint any chipped, bare, or rusted areas to prevent any further deterioration. Inspect the machine for any worn or broken parts and adjust or replace as required.

*See your Wil-Rich dealer for any parts and/or service which may be needed.*

Thoroughly lubricate all grease fittings at the end of the season's use and again before the first operation of the next season.

It is advisable, if possible to store larger field cultivators with the wings down. With the wings completely lowered, the rod end cylinder pins of the wing lift cylinders should be removed and cylinders carefully retracted.

Avoid possible damage to the hydraulic system by lowering the machine onto the shanks and relieve the pressure on the system. Doing this will also prevent damage to the tires by removing the field cultivator's weight.

Coat the shovels with grease and place boards under the points to prevent the shovels from settling into the ground.

## SHOVELS

Shovels should be used for general tillage, seed-bed preparation and weed control.

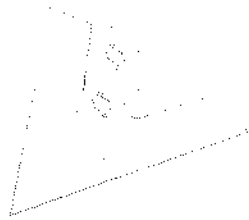

4" shovel (924)

7" High Crown Shovel

9" High Crown Shovel

9" Dura-Face Shovel

7" Low Crown Shovel (924)

9" Low Crown Shovel (924)

10" Low Crown Shovel (924)

12" Low Crown Shovel (924)

10" High Crown Shovel

12" High Crown Shovel

**Note: Wil-Rich shanks have a 52° shank angle and a 47° sweep angle is recommended.**

## SPIKES

Spikes are recommended for deep penetration, hard soil conditions, killing of quack grass and other grassy weeds, and also general tillage. These spikes are reversible for longer wear.



## SHOVEL EXTENSION

A shovel extension kit is available for increase shovel penetration behind wheel tracks.

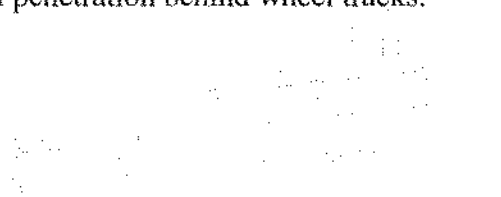

## TROUBLE SHOOTING

PROBLEM	POSSIBLE CAUSE	SOLUTION
Poor or uneven penetration.	<p>Incorrect leveling adjustments on main frame or wings.</p> <p>Sweeps with incorrect stem angle.</p> <p>Hydraulic malfunction - air in lines, cylinders or hoses leaking or not installed properly.</p> <p>Tires not equally inflated.</p>	<p>See leveling</p> <p>See page 46</p> <p>Make sure wing cylinders are fully extended.</p> <p>Check for oil leakage in cylinders, hoses and fittings. Make sure all hydraulic cylinders and hose are properly connected.</p> <p>See tire inflation.</p>
Settling of entire implement from raised position.	<p>Leaking cylinder.</p> <p>Leaking tractor hydraulic control valve.</p>	<p>Replace cylinder seals</p> <p>See tractor Manual.</p>
Wings unfolding to rapidly.	<p>Incorrect cylinder installed, should have 1/16" dia. integral restrictor cylinder.</p>	<p>See wing lift circuitry and install correct cylinder.</p>
Machine will not pull straight, (skewing).	<p>Cultivator not level.</p> <p>Incorrect shank placement.</p> <p>Shovels wore.</p> <p>Tires not equally inflated.</p>	<p>See leveling</p> <p>Check shanks for proper location, see assembly.</p> <p>Replace shovels.</p> <p>See tire inflation.</p>
Wings running at different depths after setting	<p>Wings out of adjustment.</p>	<p>Reset wing height and tighten jam nut.</p>

