



PARTS

500 GALLON 3PT **SPRAYER**

 WIL-RICH

PO Box 1030

Wahpeton, ND 58074

PH (701) 642-2621

Fax (701) 642-3372

74284 3/11/07

500 GALLON TMII TANK ASSEMBLY

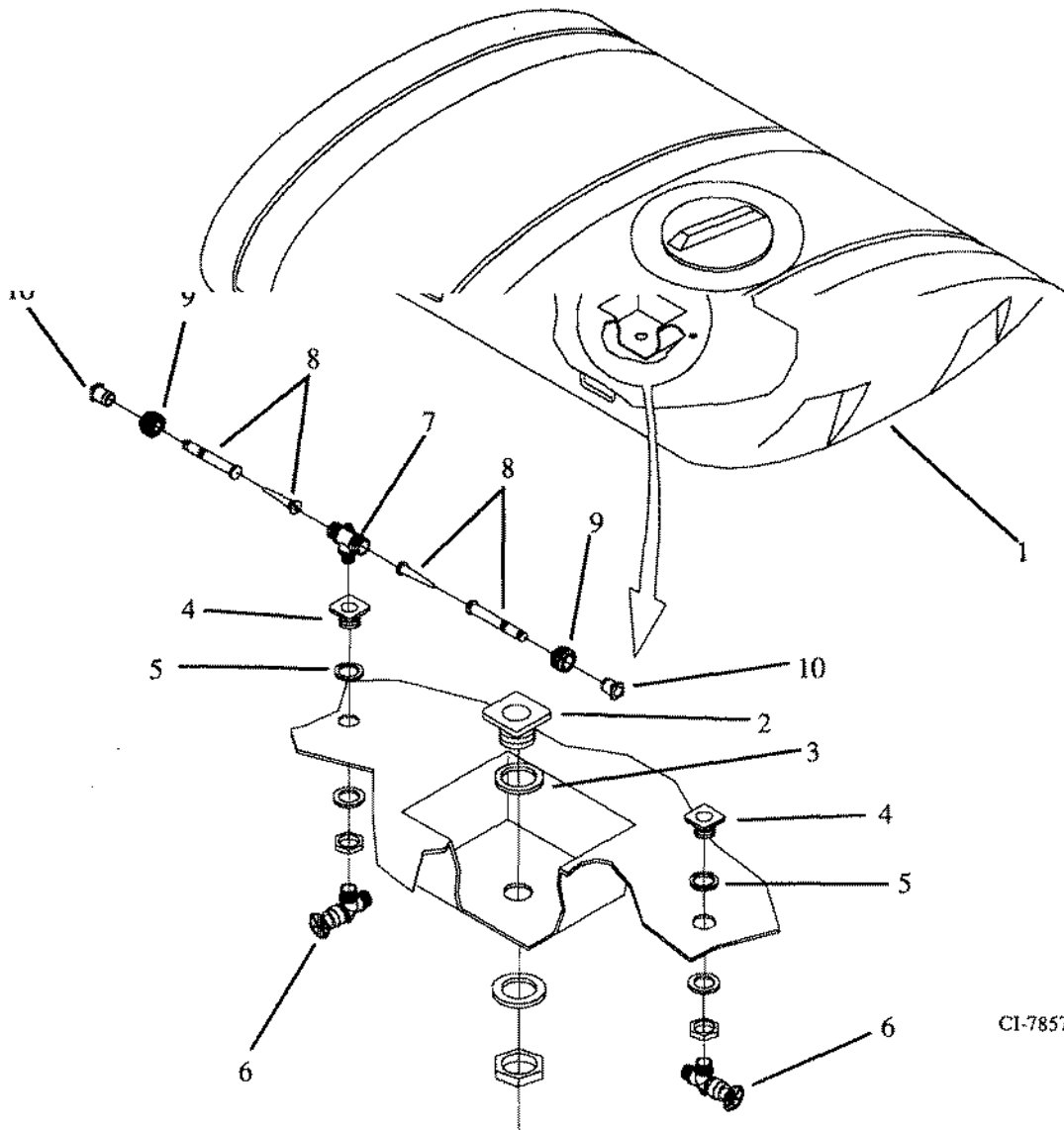

ITEM	PART NO.	DESCRIPTION	ITEM	PART NO.	DESCRIPTION
1	53456	500 GAL ELPTCL TNK W/FITTINGS	5	45814	BULKHEAD GASKET 1/2 & 3/4
2	43394	1-1/2" NYLON BULKHEAD FITTING	6	43514	3/4MPT X1MSPT TEE VALVE
3	45817	BULKHEAD GASKET 1-1/2 & 2	7	46099	1"MSPTX3/4"MPTX1"MSPT TEE
4	43387	3/4" NYLON BULKHEAD FITTING	8	43642	JET AGITATOR W/ 1/8" ORIFICE
			9	46129	1"FSPT SW NUT
			10	45998	1"SW X 3/4" FEMALE SLIP (AGTR)

MAIN FRAME

Note: 3PT bolt together CROSS BRACES must be installed to ensure proper support of mast and frame.

500 GALLON #68105

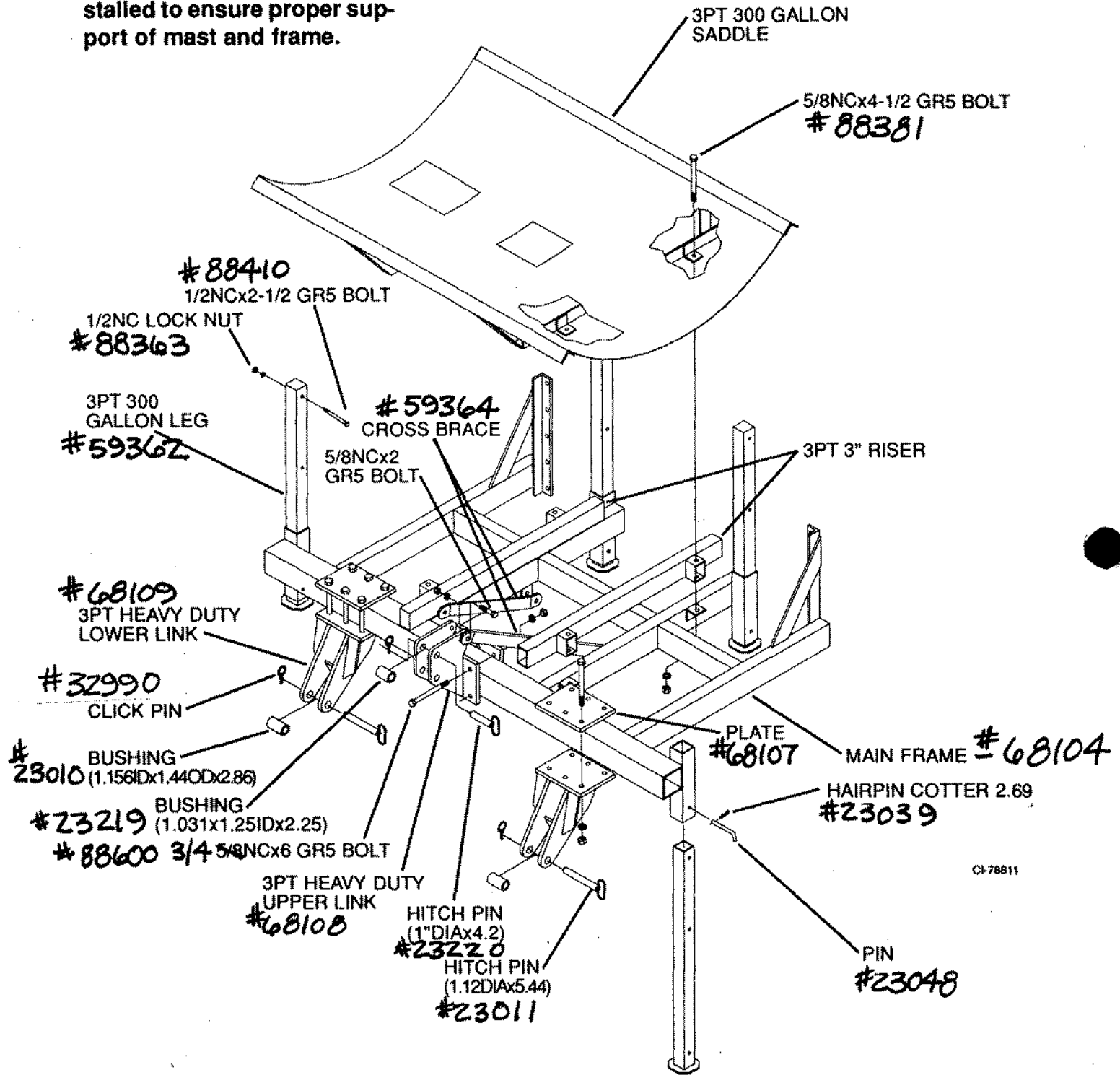

CLEAN WATER & FOAMER

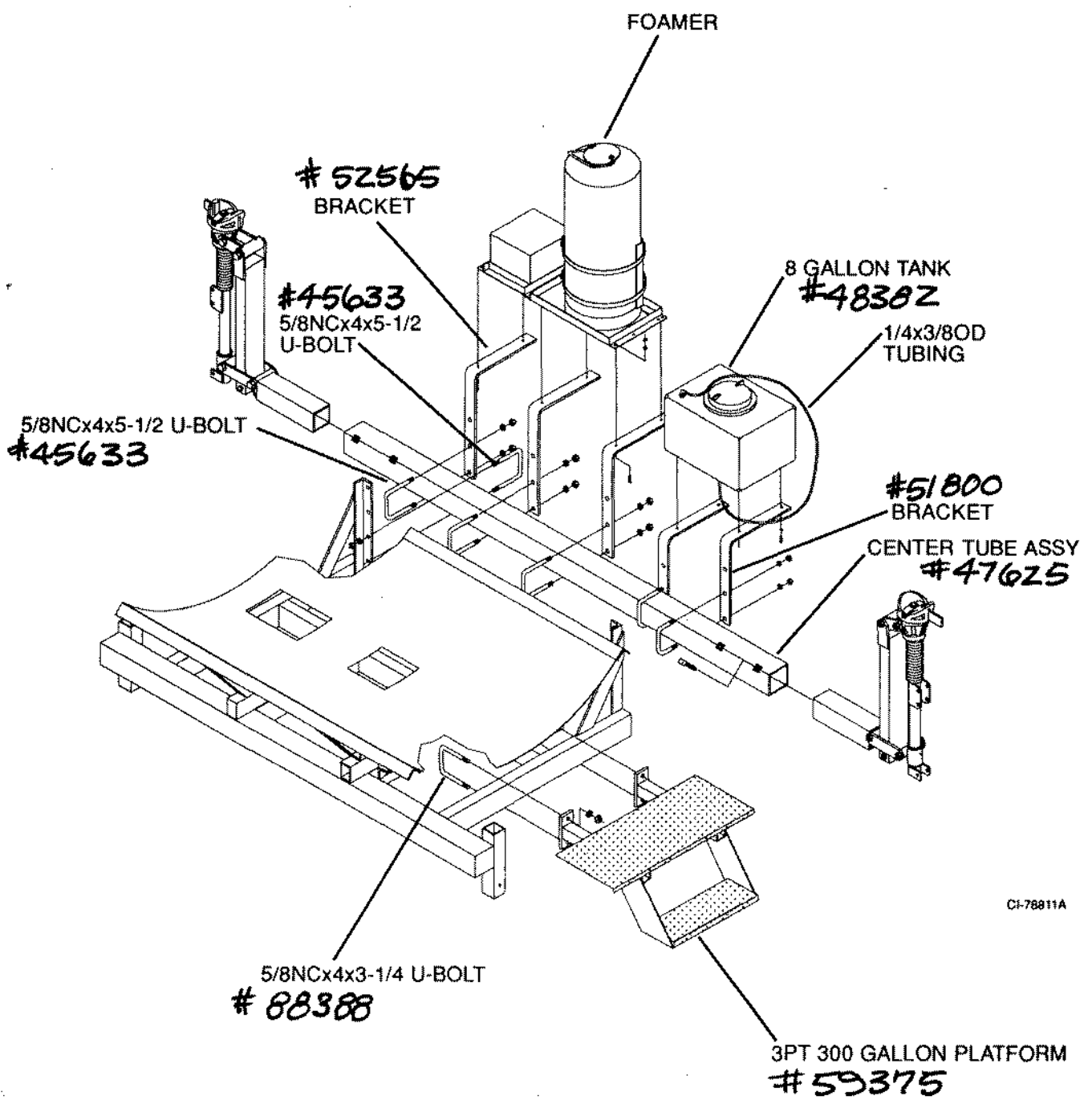

CI-78811A

500 GALLON WAGON MASTER (CROSSWISE)

CI-78038

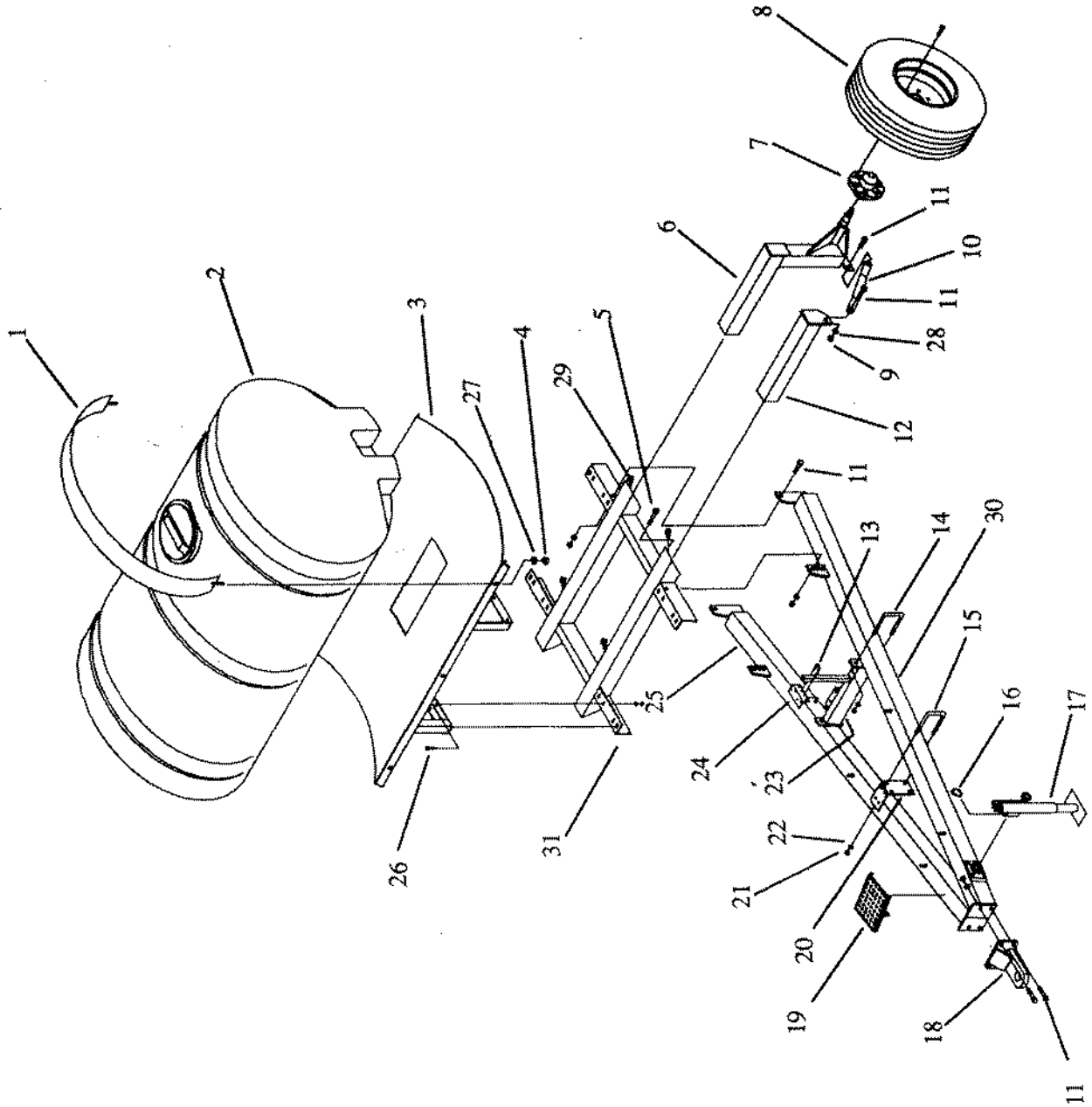

ITEM	PART NO.	DESCRIPTION
1	44914	ELLIPTICAL TANK BAND (BLUE)
2	53456	500 GAL ELPTCL TNK W/FITTINGS
3	44915	500 GAL ELLPTCL SADDLE (BLUE) <i>68105</i>
4	88104	NUT HEX 1/2-13NC Z
5	88111	BLT HEX 3/4-10NCX3-1/2 SZ
6	44923	AXLE W/A LEFT 500 GAL WM (SHOWN)
	44924	AXLE W/A RIGHT 500 WM
7	45838	HUB 6 BOLT 9/16 HOLES WM
	45629	LUG BOLT 90 WBIZ .562 18UNF
	45644	CONE 1.25 BORE BEARING
	45645	CONE 1.62 BORE BEARING
	45646	OUTER CUP
	45647	INNER CUP
	45735	DUST CAP
	46374	SEAL FOR H-6-001 HUB
	89031	NUT CASTLE 7/8-14NF
	89030	WSHR FLT 2ODX.937IDX.187 THE 2
	88645	PIN COT 3/16DIAX1-1/4
8	44736	WHL ASSY 12.5LX15 6B 10"8PBWHT
	30784	VALVE STEM ASSY TR415
	46511	TIRE 12.5L-15 8PLY TUBELESS
	46714	WHEEL 15X10 LBH
9	88110	NUT HEX 3/4-10NC

ITEM	PART NO.	DESCRIPTION
10	45345	500 WM AXLE SUPPORT STRUT
11	88604	BLT HEX 3/4-10NCX2 SZ
12	44922	LEFT AXLE SUPPORT TUBE 500 WM (SHOWN)
	44921	RT AXLE SUPPORT TUBE 500 WM
13	89063	BLT-U 1/4-20NCX1X1-1/2
14	88385	BLT-U 3/8-16NCX4X4-3/4 Z
15	45633	5/8X4X5-1/2 U-BOLT
16	43156	SNAP RING
17	45843	JACK (INCLUDES ITEM 16)
18	44926	OFFSET CAT HITCH
19	48872	STEP
20	47658	500 WM PTO PUMP MOUNT
21	88126	NUT HEX 5/8-11NC Z
22	88129	WSHR HLK 5/8ID(11/16ACT)
23	55494	PUMP/SOLENOID BRACKET
24	55503	SOLENOID MOUNT
25	44920	500 RIGHT HITCH POLE W/A
26	88554	BLT HEX 1/2-13NCX1-1/4 SZ
27	88303	WSHR HLK 1/2ID (9/16ACT)
28	88130	WSHR HLK 3/4ID (13/16ACT)
29	88979	SCR SET 3/4-10NC X 1-1/2 SQHD
30	44919	500 WM LEFT HITCH POLE W/A
31	44927	500 GAL ELLIPTICAL FRAME W/A

500 GALLON WAGON MASTER (CROSSWISE)

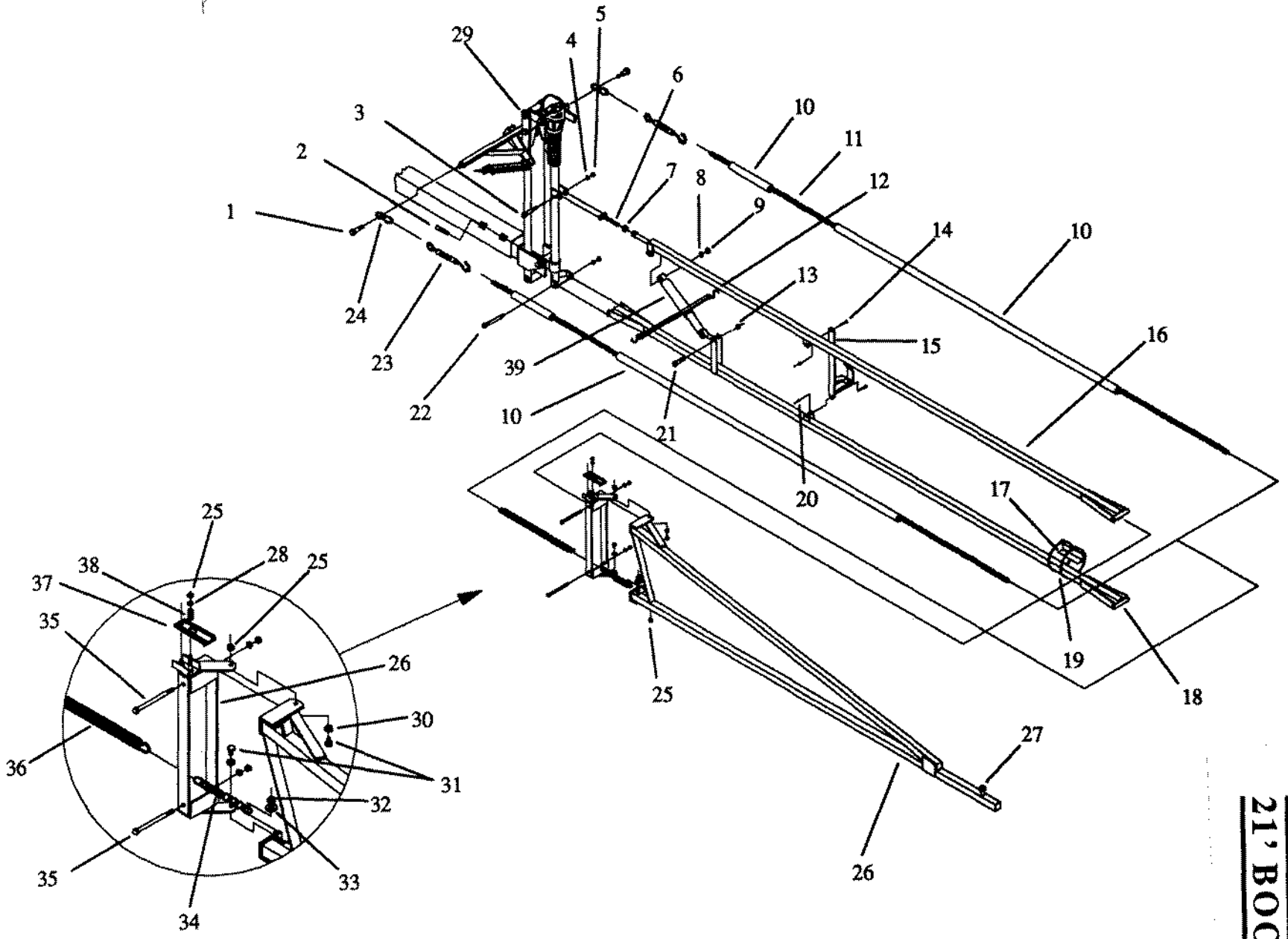

21' BOOM

6

ITEM	PART NO.	DESCRIPTION
	44543	LEFT BOOM ASSY COMPLETE 21'
	44547	RIGHT BOOM ASSY COMPLETE 21'
1	47196	SHOULDER BOLT 5/8X1-1/4X1/2
2	88979	SCR SET 3/4-10NC X 1-1/2 SQ HD
3	45624	7/16NC X 2.625 SHOULDER BOLT
4	88269	WSHR HLK 7/16ID(1/2ACT)
5	88270	NUT HEX 7/16-14NC Z
6	50377	BOOM SHORTENER
7	88126	NUT HEX 5/8-11NC Z
8	88277	WSHR FLAT 5/8(11/16X1-3/4ACT)Z
9	88369	NUT 2POSLK 5/8-11NC
10	53496	TUBING 1-1/8IDX1-1/4ODX1'
11	44794	CHAIN ASSEMBLY (INCLUDES ITEMS 23 & 24)
12	44685	TARP STRAP
13	88363	NUT 2POSLK 1/2-13NC
14	88478	BLT HEX 5/16-18NCX1 5Z
15	44857	HANGER BRKT W/A
16	44891	12FT UPPER MAIN BOOM (INCLUDES ITEMS 6 & 7)
17	55745	BOOM TUBE PROTECTOR
18	44889	12FT LOWER MAIN BOOM
19	45740	HOSE CLAMP 2-1/4
20	88540	NUT 2POSLK 5/16-18NC

ITEM	PART NO.	DESCRIPTION
21	88410	BLT HEX 1/2-13NCX2-1/2 5Z
22	45625	7/16NC X 5.125 SHOULDER BOLT
23	46510	TURN BUCKLE
24	46393	S-HOOKS 5/16 X 3 X 7/8
25	88162	NUT 2POSLK 3/8-16NC
26	44887	LEFT 9FT BOOM OUTRIGGER (SHOWN)
	44886	RIGHT 9FT BOOM OUTRIGGER (INCLUDES ITEMS 25,27,28,30,31,37,38)
27	88807	BLT HEX 5/16-18NCX3/4 2Z
28	88282	WSHR FLAT 3/8(7/16X1ACT) Z
29	44544	LEFT BOOM POST ASSY (INCLUDES ITEM 1)
	44548	RIGHT BOOM POST ASSY (INCLUDES ITEM 1)
30	46763	PUNCH OUT SPACER WASHER
31	45620	SCK HD SHLD BLT 1/2X1/2X3/8
32	88540	NUT 2POSLK 5/16-18NC
33	88278	WSHR FLAT 5/16 (3/8X7/8 ACT)
34	45144	CHAIN TWIST LINK SPRAY BOOM
35	45625	7/16NC X 5.125 SHOULDER BOLT
36	46397	20" SPRING FOR SPRAYER BOOM
37	44878	OUTRIGGER BOOM RELEASE
38	46400	COMPRESSION SPRING
39	46364	SHOCK ABSORBER FOR BOOMS

21' BOOM

HYDRAULIC TILT

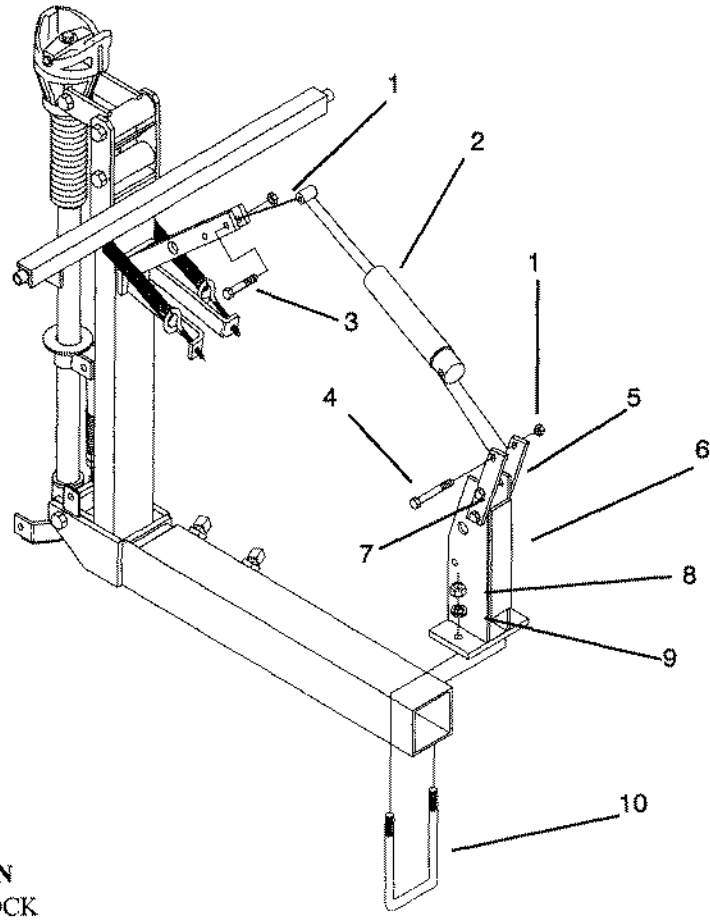

ITEMPART NO.	DESCRIPTION
1	88363 NUT 1/2NC LOCK
2	45752 HYDRAULIC BOOM LIFT CYLINDER
	61379 SEAL KIT
3	88541 BOLT 1/2NCx3
4	88507 BOLT 1/2NCx3-1/2
5	50018 EAR
6	44861 HYDRAULIC LIFT BRACKET
7	88554 BOLT 1/2NCx1-1/4
8	88126 NUT 5/8NC
9	88129 WASHER 5/8 LOCK
10	45633 U-BOLT 5/8NCx4x5-1/2

CHEMICAL INDUCTOR

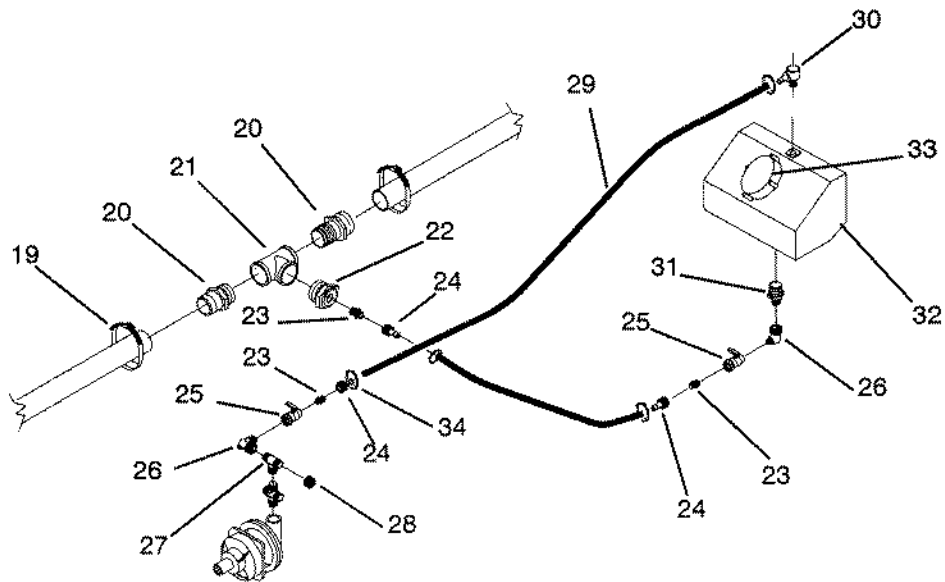
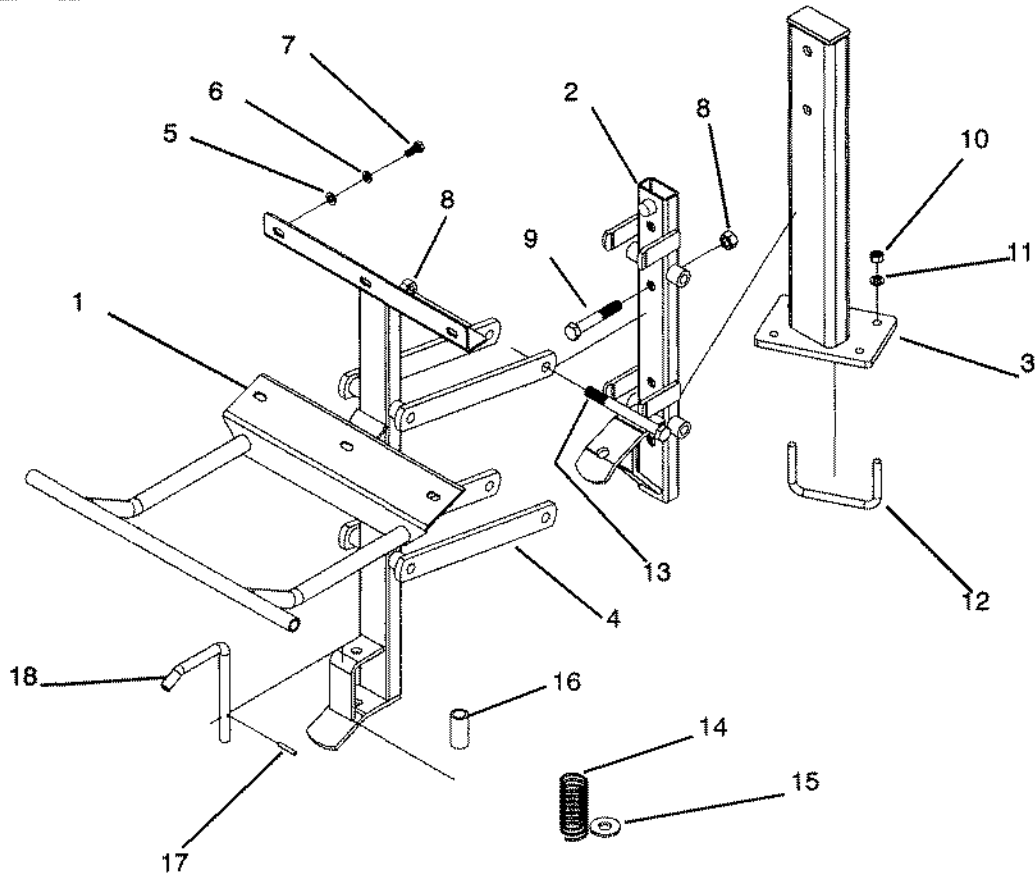

CHEMICAL INDUCTOR

ITEM	PART NO.	DESCRIPTION
1	69272	TANK MOUNT
2	69273	SUPPORT
3	69296	MOUNT
4	69275	STRAP
5	88278	WASHER 5/16 FLAT
6	88358	WASHER 5/16 LOCK
7	88807	BOLT 5/16NCx3/4
8	88363	NUT 1/2NC
9	88541	BOLT 1/2NCx3
10	88103	NUT 3/8NC
11	88362	WASHER 3/8 LOCK
12	88515	U-BOLT 3/8NCx4x2-3/4
13	88681	BOLT 1/2NCx5
14	15940	STAINLESS COMPRESSION SPRING
15	88347	WASHER 1/2 FLAT
16	69277	BUSHING
17	88856	ROLL PIN 3/16x1-1/8
18	69276	LATCH
19	45740	2-1/4 SS CLAMP (8-1/4 LG)
20	46175	1-1/2MPTx1-1/2HB ADAPTER
21	46258	1-1/2 FPT TEE
22	46217	1-1/2MPTx1MPT BUSHING
23	45985	1 MSPTx1MPT NIPPLE
24	44496	1 NUT x1/2 HB ADAPTER
25	47906	1 BALL VALVE
26	61189	1 NUT x 1 MPT ELBOW
27	44553	1 MSPT x 1 NUT x 1 MSPT TEE
28	46134	1 FSPT CAP
29	220530	1/2 CLEAR VINYL HOSE
30	236296	3/4MPTx1/2HB ELBOW
31	45971	1-1/4 MPTx1 MSPT ADAPTER
32	69274	6 GAL EDUCTOR TANK
33	238211	CAP
34	45731	3/4 SS CLAMP (3-1/4 LG)

FOAM MARKER

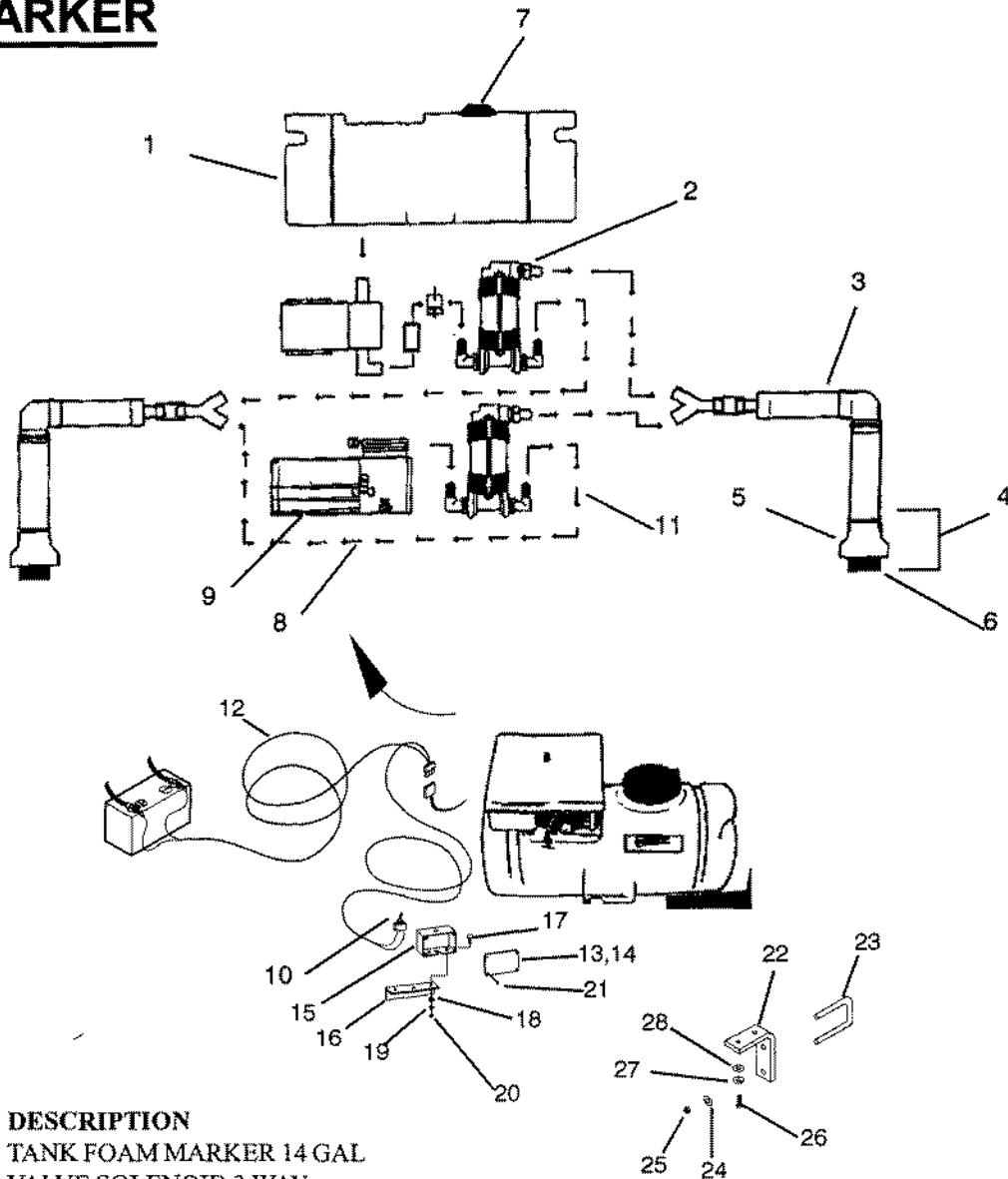

ITEMPART NO.	DESCRIPTION
1	223966 TANK FOAM MARKER 14 GAL
2	223968 VALVE SOLENOID 3 WAY
3	223971 FOAM CHAMBER W/ HOSE
4	223972 COLLECTOR BOOT/SOCKET SET
5	223973 COLLECTOR BOOT W/ CLAMP
6	223974 COLLECTOR SOCK
7	238211 COVER 6" SPRING VENT
8	45991 1/4 HOSE MENDER
9	223967 COMPRESSOR AIR 12 VOLT HI-CAP
10	223975 SWITCH FOAM MARKER
11	55743 1/4" CLEAR VINYL HOSE (100')
12	238250 HARNESS MAIN WIRE W/ SWITCH
	235648 FUSE 20A
13	237490 DECAL FOAM MARKER
14	62584 CONSOLE PANEL
15	62583 CONSOLE BOX
16	50346 ANGLE
17	88996 CARRIAGE BOLT 1/4NCx1-1/4
18	88855 WASHER 1/4 FLAT
19	89036 WASHER 1/4 LOCK

ITEMPART NO.	DESCRIPTION
20	88172 NUT 1/4NC
21	89136 #6x1/2 SELF TAPPING SCREW
22	52565 BRACKET
23	45633 U-BOLT 5/8NCx4x5-1/2
24	88129 WASHER 5/8 LOCK
25	88126 NUT 5/8NC
26	88478 BOLT 5/16NCx1
27	88358 WASHER 5/16 LOCK
28	88278 WASHER 5/16

11

TEEJET BALL VALVE

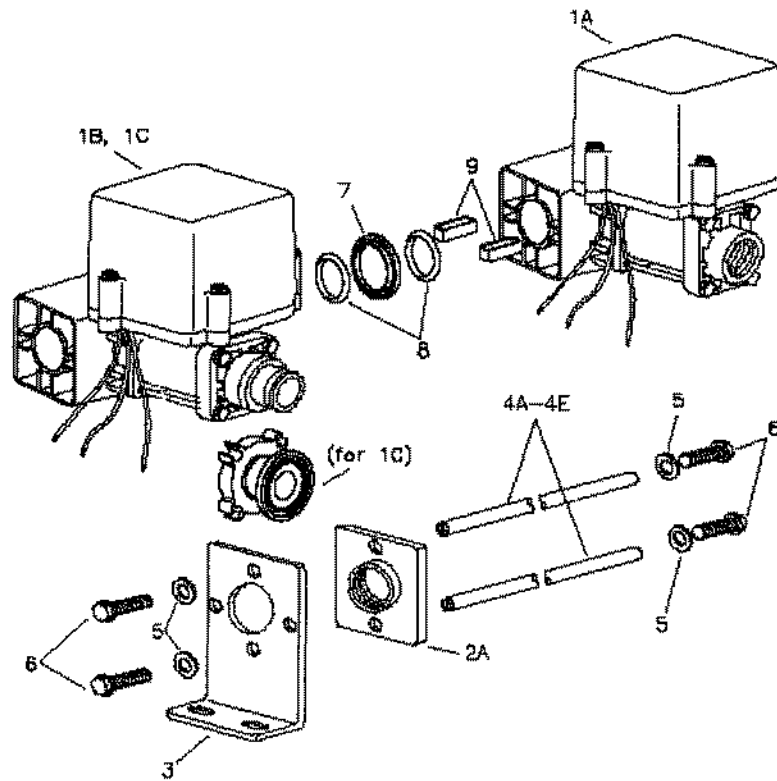

ITEM	PART NO	DESCRIPTION
1	B112992	VALVE BALL SHUTOFF 1" 12 VDC (NOT SHOWN)
1A	238208	VALVE ELECTRIC BALL 1" MNFLD TEEJET
2A	221374	1 NPT F THREADED INLET BODY
3	N/A	BRACKET MOUNTING
4	N/A	STUD
5	88882	WASHER FLAT 1/4(5/16X3/4ACT) SST
6	89105	BOLT HEX 1/4-20NC X 1 SST
7	221375	INNER CONNECTOR POLY
8	221376	O-RING VITON
9	N/A	INSERT ALIGNMENT

HYPROPUMP

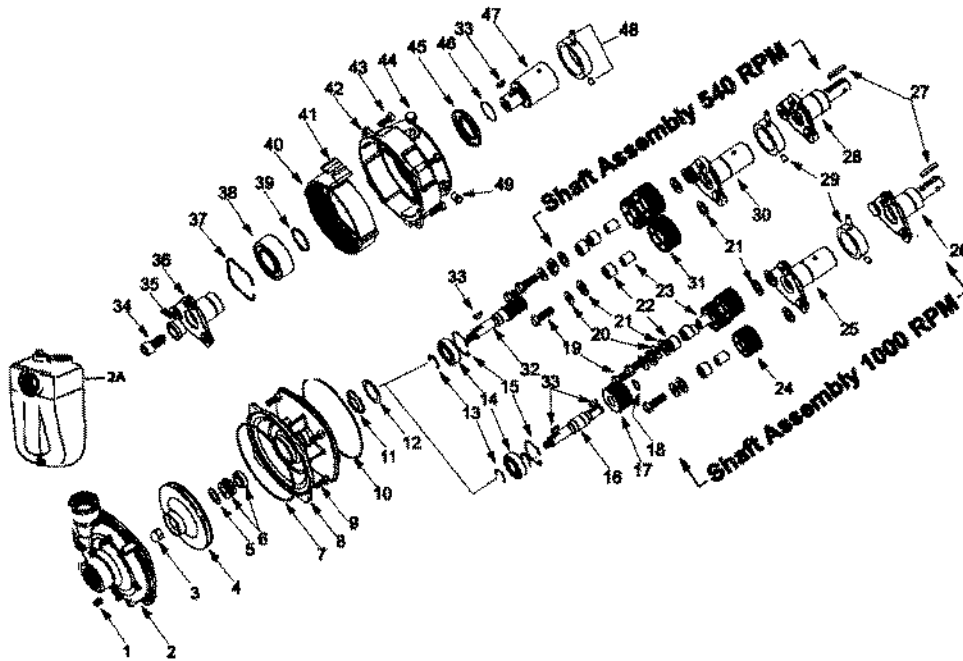

ITEM	PART NO	DESCRIPTION	ITEM	PART NO	DESCRIPTION
1	60213	DRAIN/VENT PLUG	29	N/A	LOCKING COLLAR KIT
2	43286	PUMP CASING	30	60198	DRIVER HUB
3	44446	IMPLR NUT	31	58036	DRIVER GEAR
4	43291	IMPELLAR	32	44741	PINION GEARED SHAFT
5	N/A	GASKET	33	43356	WOODRUFF KEY
6	44435	BUNA-N SEAL	34	N/A	CAPSCREW
6	44436	VITON SEAL	35	N/A	BUSHING
7	43364	O-RING CAST	36	N/A	HUB DRIVER
8	N/A	MNT FLANGE	37	60203	RETAINING RING
9	44441	CAPSCREW	38	44422	BALL BEARING
10	60211	O-RING	39	43370	SNAP RING
11	N/A	BEARING LIP SEAL	40	44740	GEAR RING 9000 SERIES
12	60210	GASKET	41	43352	CUSHION BUMPER
13	43372	RETAINING RING	42	60205	GEAR CASING
14	44424	BEARING Ø.96X2.05OD	43	N/A	CAPSCREW
15	43378	RETAINER RING	44	60208	BREATHER VENT
16	N/A	IMPELLAR SHAFT	45	60204	OIL SEAL
17	44742	SUN GEAR	46	60212	O-RING
18	43371	RETAINING RING	47	60206	DRIVER HUB (9028C)
19	N/A	CAPSCREW	48	60207	LOCK COLLAR 9028C
20	44440	CAPSCREW	49	60209	OIL PLUG
21	44448	NYLN THRST WSHR	50	238206	REPAIR KIT (INCLUDES ITEMS 5,6,&7)
22	N/A	BEARING W/DRIVER GEAR			
23	44423	BEARING INNER RACE			
24	60197	DR GEAR W/BRG(1000RPM)			
25	60199	DRIVER HUB			
26	60201	DR HUB (1000RPM)			
27	43355	WOODRUFF KEY			
28	60200	DRIVER HUB (540 RPM)			

TEEJET CONTROL BOX

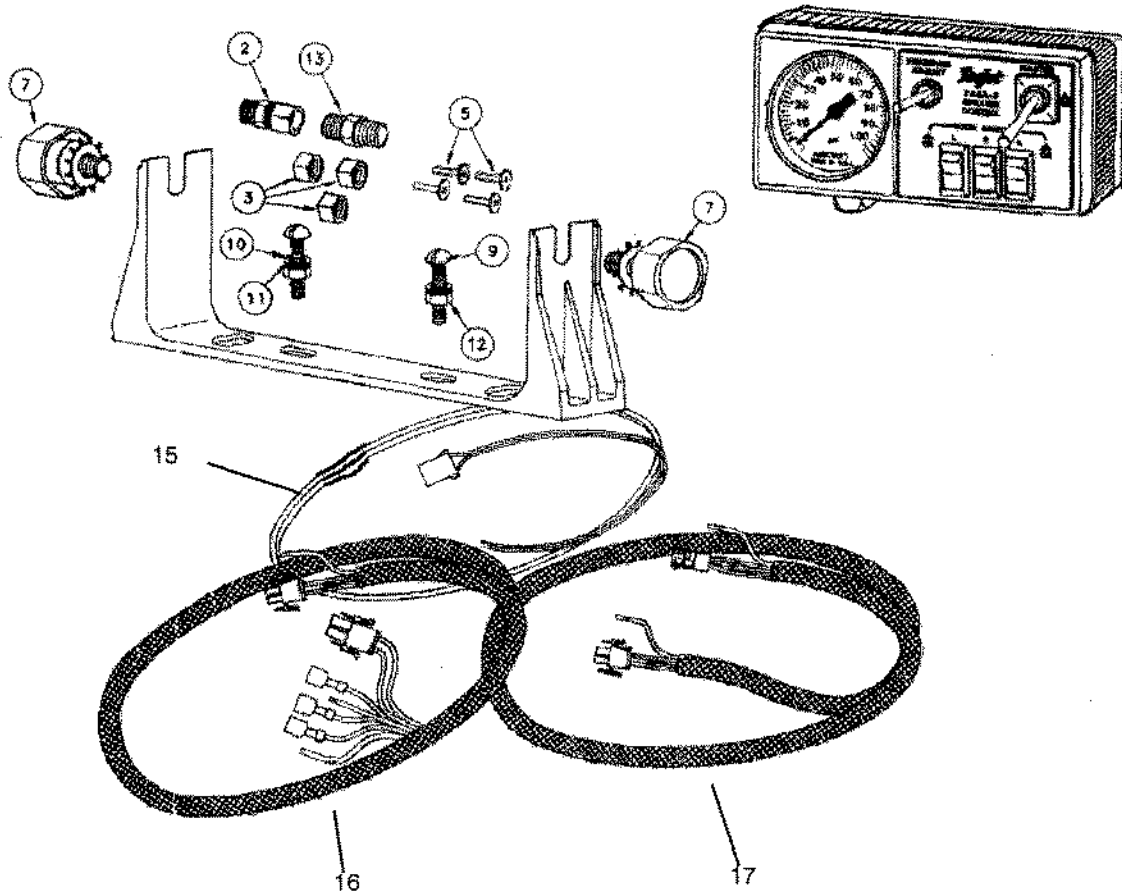

ITEM	PART NO	DESCRIPTION
1	N/A	
2	46579	1/8" TUBE CONNECTOR
3	B112778	1/8" FPT TUBING NUT NYLON
4	N/A	
5	B112780	TUBING INSERT BRASS
6	N/A	
7	B115129	KNOB LOCK PLASTIC
8	N/A	
9	88203	BLT HEX 1/4-20NCX1 5Z
10	88261	WSHR FLAT 1/4(5/16X3/4ACT) Z
11	88262	WSHR HLK 1/4ID(5/16ACT) Z
12	88172	NUT HEX 1/4-20NC 5Z
13	46580	1/8" TUBE UNION
14	B115108	TUBING NYLON BLACK (NOT SHOWN)
15	B112923	CABLE POWER
16	B112918	CABLE END
17	B112924	CABLE EXT

TEEJET 744 CONTROL

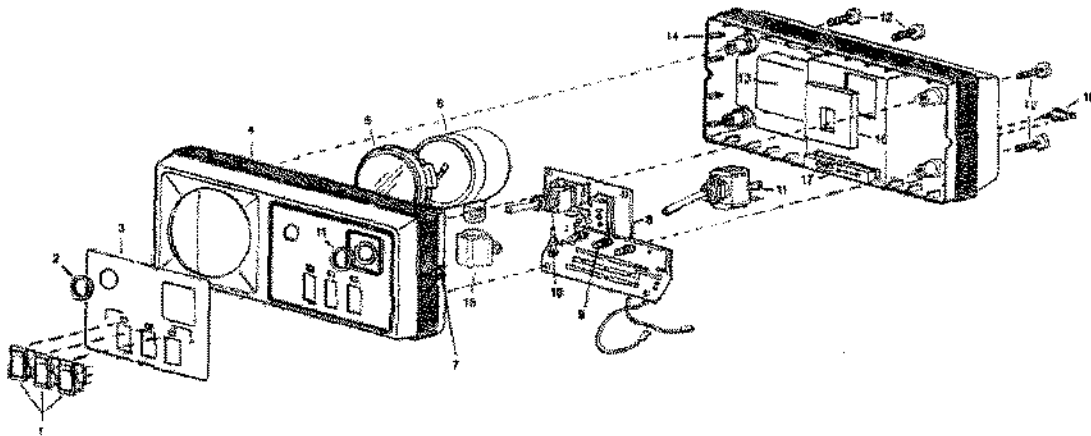

ITEM	PART NO.	DESCRIPTION
6	B115122	GAUGE PRESSURE 100 PSI FILLED
11	B112887	SWITCH TOGGLE
15	B112767	ADAPTER ELBOW

TEE JET QJ 363 VERSION C

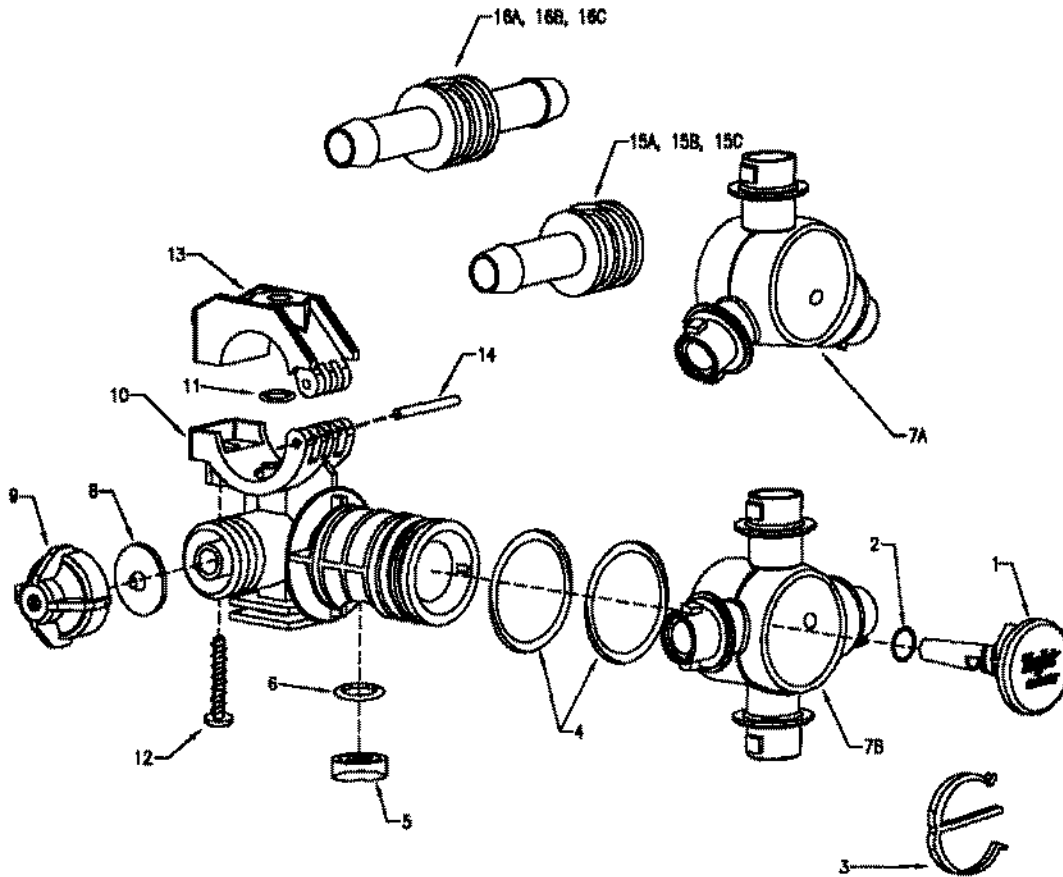

ITEM	PART NO.	DESCRIPTION
1	238231	PLUG NYLON
2	238232	O-RING TURRET PLUG
3	238233	E-CLIP TURRET
4	238234	O-RING TURRET
5	238235	SEAL NOZZLE PORT
6	238236	O-RING NOZZLE PORT
7A	238237	TURRET TRIPLE PORT
8	238230	DIAPHRAM, EPDM
9	B112886	END CAP CEMSAVER
10	N/A	
11	B115134	O-RING
12	238238	SCREW BODY STAINLESS
13	238239	BODY CLAMP TOP
14	238240	PIN BODY PIVOT
15B	238241	HOSE BARB SINGLE 3/4"
16B	238242	HOSE BARB DOUBLE 3/4"
17	65074	TRIPLE NOZZLE L BODY (COMPLETE)
18	65075	TRIPLE NOZZLE T BODY (COMPLETE)

TEE JET QJ 363 PRIOR VERSION C

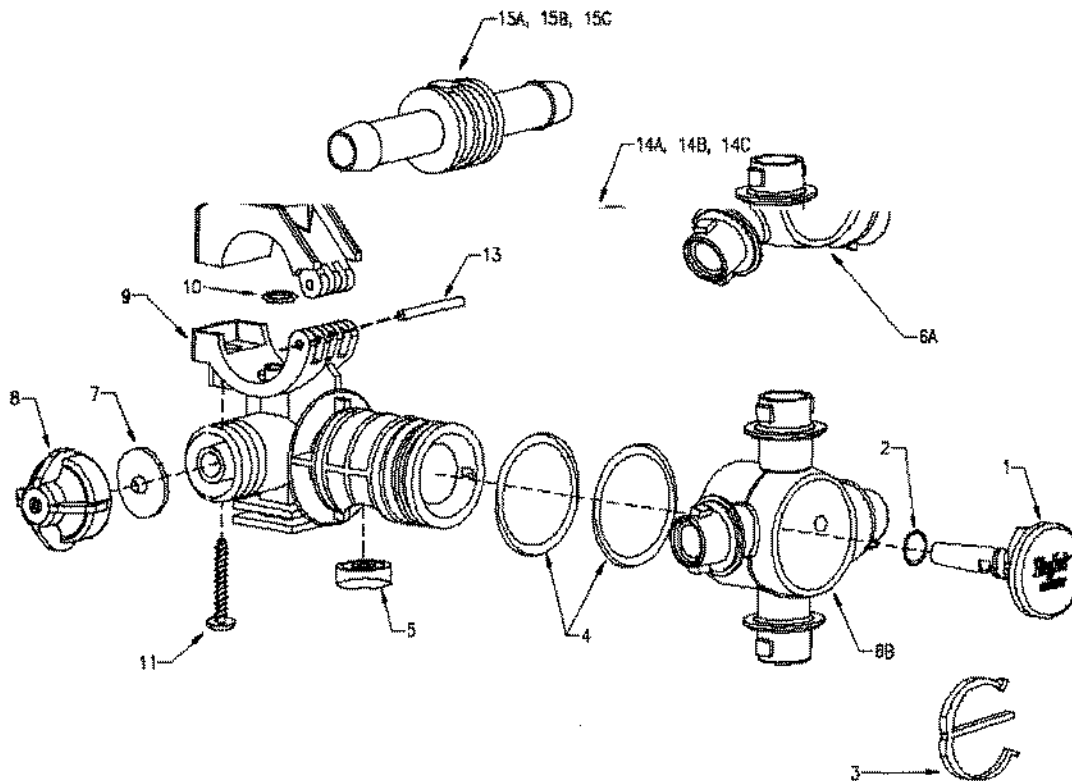

ITEM	PART NO.	DESCRIPTION
1	238243	PLUG NYLON
2	238232	O-RING TURRET PLUG
3	238233	E-CLIP TURRET
4	238234	O-RING TURRET
5	238244	SEAL NOZZLE PORT
6A	238237	TURRET TRIPLE PORT
7	238230	DIAPHRAM EPDM
8	B112886	ENDCAP CHEMSAVER
9	N/A	
10	B115134	O-RING
11	238238	SCREW BODY STAINLESS
12	238239	BODY CLAMP TOP
13	238240	PIN BODY PIVOT
14B	238241	HOSE BARB SINGLE 3/4"
15B	238242	HOSE BARB DOUBLE 3/4"
16	65074	TRIPLE NOZZLE L BODY (COMPLETE)
17	65075	TRIPLE NOZZLE T BODY (COMPLETE)

TEEJET SINGLE NOZZLES

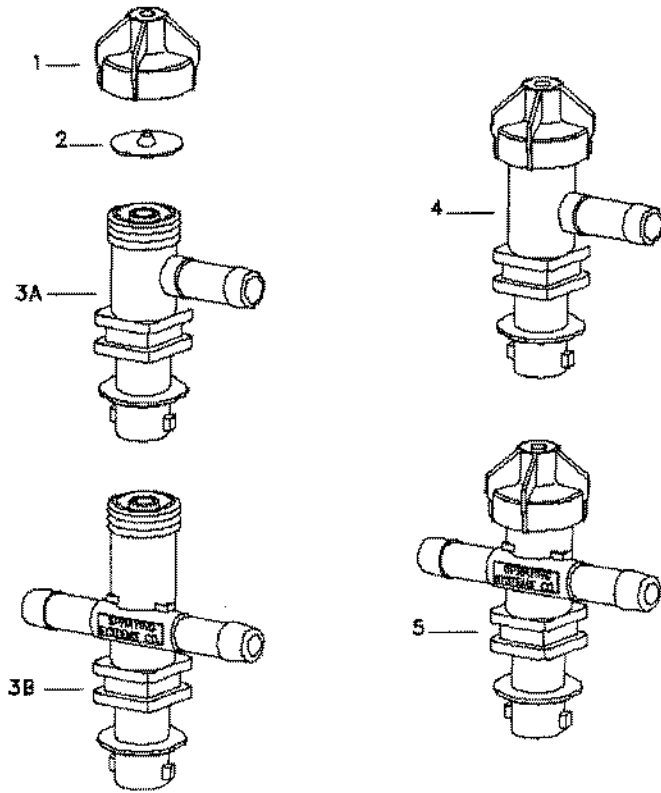

TEMPART NO.	DESCRIPTION
1	B112886 END CAP CHEMSAVER
2	238230 DIAPHRAM
A	N/A
B	N/A
4	60190 NOZZLE L 3/4" HB CHECK (COMPLETE)
5	60191 NOZZLE T 3/4" HB CHECK (COMPLETE)

NOTES: 1) FINISH - PAINT WIL-RICH RED.

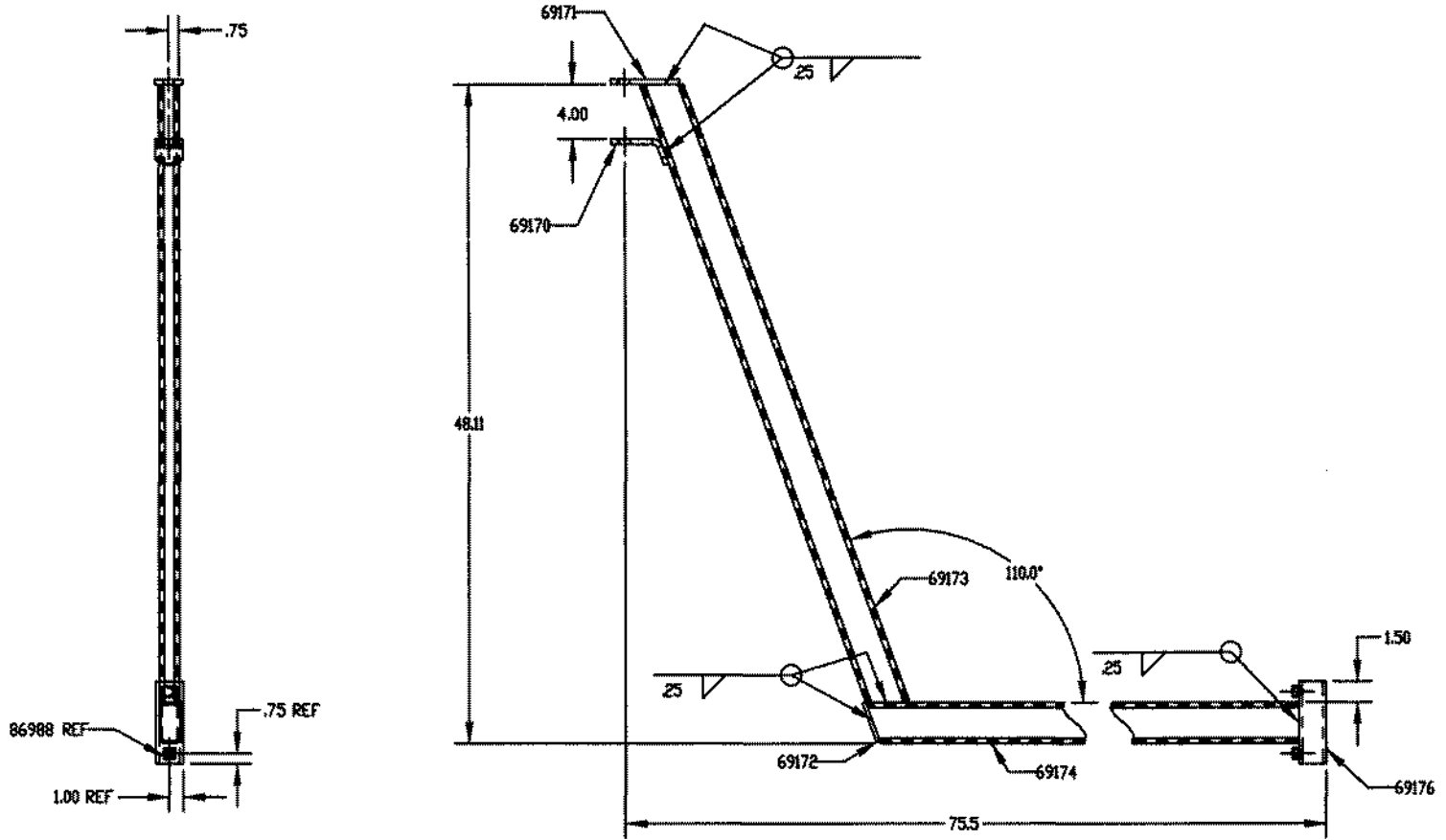

PRO-E

				06169	MATERIAL		NOTED	
					TOLERANCE UNLESS SPECIFIED		WIL-RICH a division of TIC UNITED CORP. BOOM HOLDER ASSEMBLY	
					DECIMAL: X ±.06 (1.5)			
					HOLE DIA: -.005 ±.015 (-0.13 ±0.38)			
019901	KEN	1/99	A	RELEASE	ANGLES ±1.5° METRIC ()		SCALE 0.120 DWG 69190	
ED	BY	DATE	LTR	REVISION	PREP KEN 1-16-99	CHK	APPVD	

DO NOT SCALE THIS DRAWING

NOTICE: WIL-RICH a division of TIC UNITED CORP. claims proprietary rights to the information disclosed in this drawing. It is issued in confidence for engineering information only, and may not be reproduced or used to manufacture anything shown hereon without direct written permission from WIL-RICH a division of TIC UNITED CORP. to the user.

19

NOTES: 1) FINISH - PAINT WIL-RICH RED.

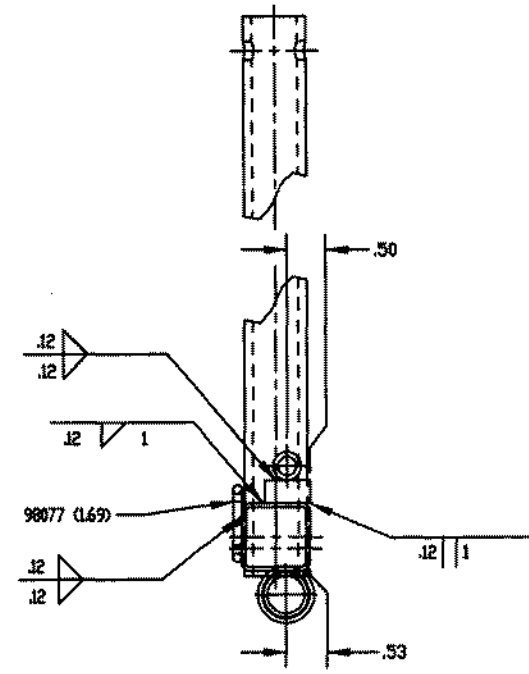
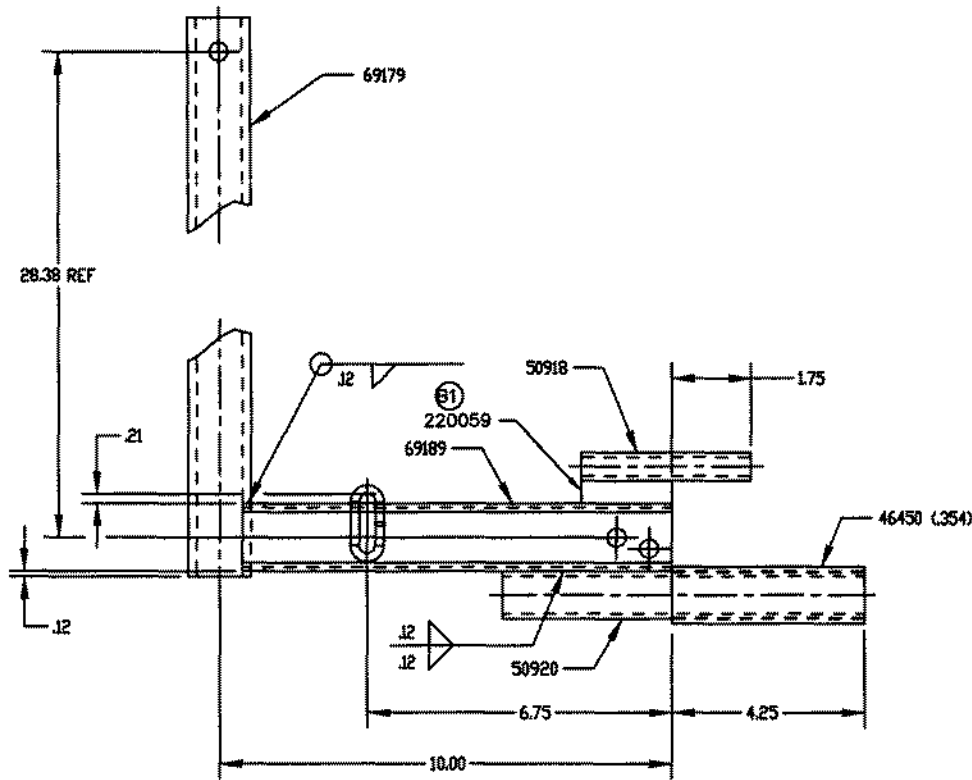

P/N	DESCRIPTION	VIEW
69177	3PT MANUAL BOOM HOLDER - RIGHT	OPPOSITE
69184	3PT MANUAL BOOM HOLDER - LEFT	SHOWN

PRO-E

ED	BY	DATE	LTR
080003	LM	8/00	B1
019901	KEN	1/99	A

DATE	DESCRIPTION
12754	RELEASE
	REVISION

MATERIAL	NOTED
TOLERANCE UNLESS SPECIFIED DECIMAL: X ±.06 (0.5) XX ±.03 (0.8) XXX ±.015 (0.38)	WIL-RICH a division of TIC UNITED CORP.
HOLE DIA: -.005 +.015 [-0.13 +0.38]	
ANGLES: ±15° METRIC () DO NOT SCALE THIS DRAWING	3PT MANUAL BOOM HOLDER
PREP KEN 1-9-99	SCALE 0.380 DWG NO. 69177-69184

NOTICE: WIL-RICH a division of TIC UNITED CORP. claims proprietary rights to the information disclosed in this drawing. It is issued in confidence for engineering information only, and may not be reproduced or used to manufacture anything shown hereon without direct written permission from WIL-RICH a division of TIC UNITED CORP. to the user.

20

NOTES: 1) FINISH - PAINT WIL-RICH RED.

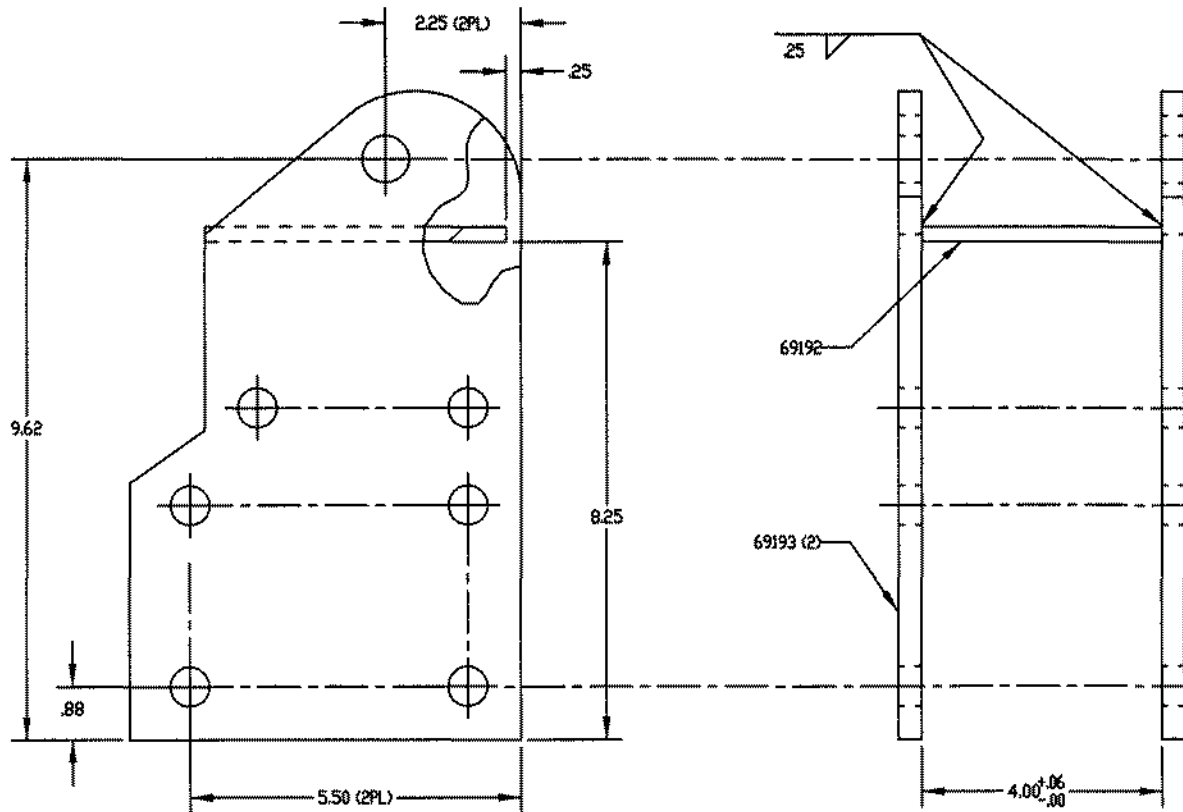

PRO-E

21

				MATERIAL		NOTED			
				TOLERANCE UNLESS SPECIFIED		<p style="text-align: center; font-size: 1.5em; margin: 0;">WIL-RICH</p> <p style="text-align: center; font-size: 0.8em; margin: 0;">a division of TIC UNITED CORP.</p>			
				DECIMAL: X ±.06 (1,5)					
				XX ±.03 (0,8)		FRAME MOUNT			
				XXX ±.015 (0,38)					
				HOLE DIA: -.005 ±.015		<p style="text-align: center;">SCALE 0.500 DWG NO. 69191</p>			
				[-0.13 +0.38]					
				ANGLES: ±1.5° METRIC ()		<p style="text-align: center;">PREP KEN 1-7-99 CHK [APVD]</p>			
				DO NOT SCALE THIS DRAWING					
				RELEASE		<p style="text-align: center;">REVISION</p>			
				MATERIAL					
019901	KEN	1/99	A						
ED	BY	DATE	LTR						
				16169					
				IN DATE					

NOTICE: WIL-RICH a division of TIC UNITED CORP. claims proprietary rights to the information disclosed in this drawing. It is issued in confidence for engineering information only, and may not be reproduced or used to manufacture anything shown hereon without direct written permission from WIL-RICH a division of TIC UNITED CORP. to the user.

- NOTES: 1.) FINISH - PAINT WIL-RICH RED
 2.) INSTALL 89046 INTO .375 DIA HOLE AS SHOWN.
 3.) OLD REV: D 52825 PICTORIALY BY KEN 8/93

DWG NO. 51250

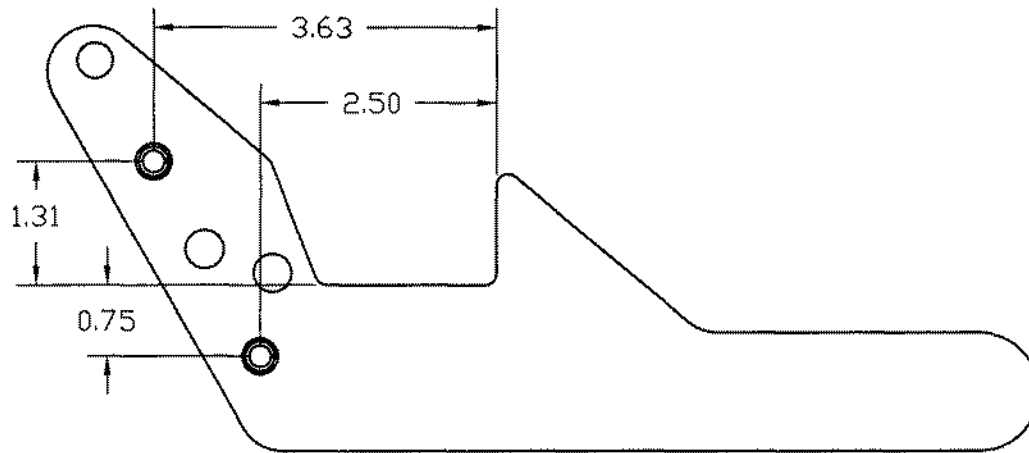
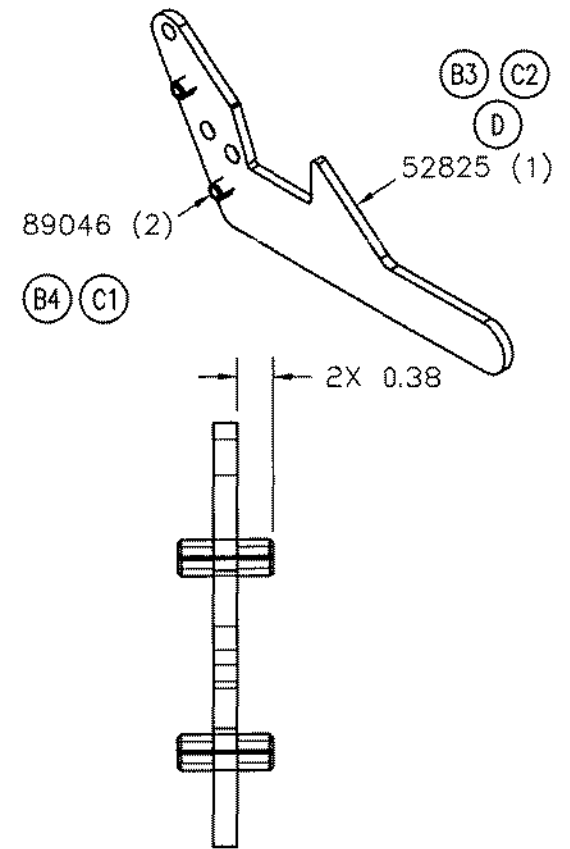

22

(B2)

0659504	KK	6/95	E	FLAT	MATERIAL	NOTED (B1)	()	STD MIL TOL UNLESS SPEC.
039111	KEN	3/91	C	1)89046 2)52825	TOLERANCE UNLESS SPECIFIED DECIMAL: .X ±.06 [1,5] .XX ±.03 [0,8] .XXX ±.015 [0,38] HOLE DIA: -.005 +.015 [-0,13 +0,38] ANGLES: ±1.5° METRIC: [] DO NOT SCALE THIS DRAWING REMOVE ALL SHARP EDGES	WIL-RICH LLC		
				4)ADDED 89046				
019104	KEN	1/91	B	1)90700 2)MATL 3)90700 - 41.625	PREP	CHK	APVD	SCALE
089008	KEN	8/90	A	RELEASE	KEN 8-9-90	WJS	JML	NONE
EO	BY	DATE	LTR	REVISION	ITEM	CLS - 062	DWG NO.	51250

TSC — NOTICE: WIL-RICH LLC claims proprietary rights to the information disclosed on this drawing. It is issued in confidence for engineering information only, and may not be reproduced or used to manufacture anything shown hereon without direct written permission from WIL-RICH LLC to the user.