

WARRANTY

The only warranty Wil-Rich gives and the only warranty the dealer is authorized to give is as follows:

We warrant products sold by us to be in accordance with our published specifications or those specifications agreed to by us in writing at time of sale. Our obligation and liability under this warranty is expressly limited to repairing, or replacing, at our option, within 12 months after date of retail delivery, any product not meeting the specifications. *We make no other warranty, express or implied and make no warranty of merchantability or of fitness for any particular purpose.* Our obligation under the warranty shall not include any transportation charges or costs or installation or any liability for direct, indirect or consequential damage or delay. If requested by us, products or parts for which a warranty claim is made are to be returned transportation prepaid to our factory. Any improper use, operation beyond rated capacity, substitution of parts not approved by us, or any alteration or repair by others in such manner as in our judgment affects the product materially and adversely shall void this warranty. *No employee or representative is authorized to change this warranty in any way or grant any other warranty.*

Wil-Rich reserves the right to make improvement changes on any of our products without notice.

When warranty limited or not applicable: Warranty on hoses, cylinders, hubs, spindles, engines, valves, pumps or other trade accessories are limited to the warranties made by the respective manufactures of these components. Rubber tires and tubes are warranted directly by the respective tire manufacturer only, and not by Wil-Rich.

Warranty does not apply to any machine or part which has been repaired or altered in any way so as in the our judgment to affect its reliability, or which has been subject to misuse, negligence or accident.

A Warranty Validation and Delivery Report Form must be filled out and received by Wil-Rich to initiate the warranty coverage.

WARRANTY CLAIMS PROCEDURE

1. The warranty form must be returned to Wil-Rich within fifteen (15) working days from the repair date.
2. Parts returned to Wil-Rich without authorization will be refused. The parts must be retained at the dealership for ninety (90) days after the claim has been filed. If the Service Department would like to inspect the parts, a packing slip will be mailed to the dealer. The packing slip must be returned with the parts. The parts must be returned prepaid within thirty (30) days of receiving authorization. After the parts are inspected and warranty is verified, credit for the return freight will be issued to the dealer.
3. Parts that will be scrapped at the dealership will be inspected by Wil-Rich Sales Representatives, District Sales Managers or Service Representatives within the ninety (90) day retaining period.

ORIENTATION

Any reference to left (L) or right (R) sides or components is to be understood as being viewed from behind the implement and looking forward.

PARTS BOOK REVISION

When changes to the implement make it necessary, revised or additional pages for this book will be issued. The revised pages will be issued with the same page number as those they replace. The additional pages will be given a page number with a letter suffix denoting the location of the new page (23A, 36A, etc.). Consecutive suffix letters would be used if more than one page is to be added to one location (23A, 23B, 23C, etc.). The revised or additional pages will also carry the machine name and the issue date to assist in identifying the book to which the parts pages apply. Revised parts book pages must be inserted into the parts book as soon as they are received, failure to do so will lead to confusion and defeat the purpose of both the books and the inserts.

SERIAL NUMBER BREAK

Every implement has a serial number located on the body of the frame. These serial numbers are consecutively assigned to the implements as they are manufactured. To aid in part ordering, we reference the serial number at the point the change occurred to provide an accurate means of determining the proper parts.

MODIFICATIONS

It is the policy of Wil-Rich Operations to improve its products whenever possible and practical to do so. We reserve the right to make changes, improvements, and modifications at any time without incurring the obligation to make such changes, improvements and modifications on any equipment sold previously.

CONTENTS

7 & 7-9 SHANK MAIN FRAME	2
7 & 7-9 CUTTER GANG	3
9, 9-11 & 9-13 SHANK MAIN FRAME	4
9, 9-11 & 9-13 CUTTER GANG	5
CUTTER GANG	6
SHANK ASSEMBLY	7
HD RIGID SHANK ASSEMBLY	8
SPIKES & TWISTED MOLDBOARDS	9
7 & 7-9 HYDRAULICS	10
9, 9-11 & 9-13 HYDRAULICS	11
2IN HUB & SPINDLE	12
2IN WALKING TANDEM	13

CYLINDERS

4 X 8 TOP BYPASS	14
4 X 8 TOP BYPASS	15
4 X 9.3 TOP BYPASS	16
DECALS	17

NON CURRENT

9 & 9-11 SHANK MAIN FRAME HITCH	18
9 & 9-11 SHANK MAIN FRAME	20
9 & 9-11 CUTTER GANG	21

ABBREVIATIONS

BLD.....	Blade
BRKT.....	Bracket
CP.....	Chisel Plow
GR.....	Grade of Bolt
HD.....	Heavy Duty
LH.....	Left-Hand Thread
NC.....	National Coarse Thread
NF.....	National Fine Thread
NPT.....	National Pipe Thread
TA.....	Tandem
TBP.....	Top Bypass
CTR.....	Center
SS.....	Screw Stop

7 & 7-9 SHANK MAIN FRAME

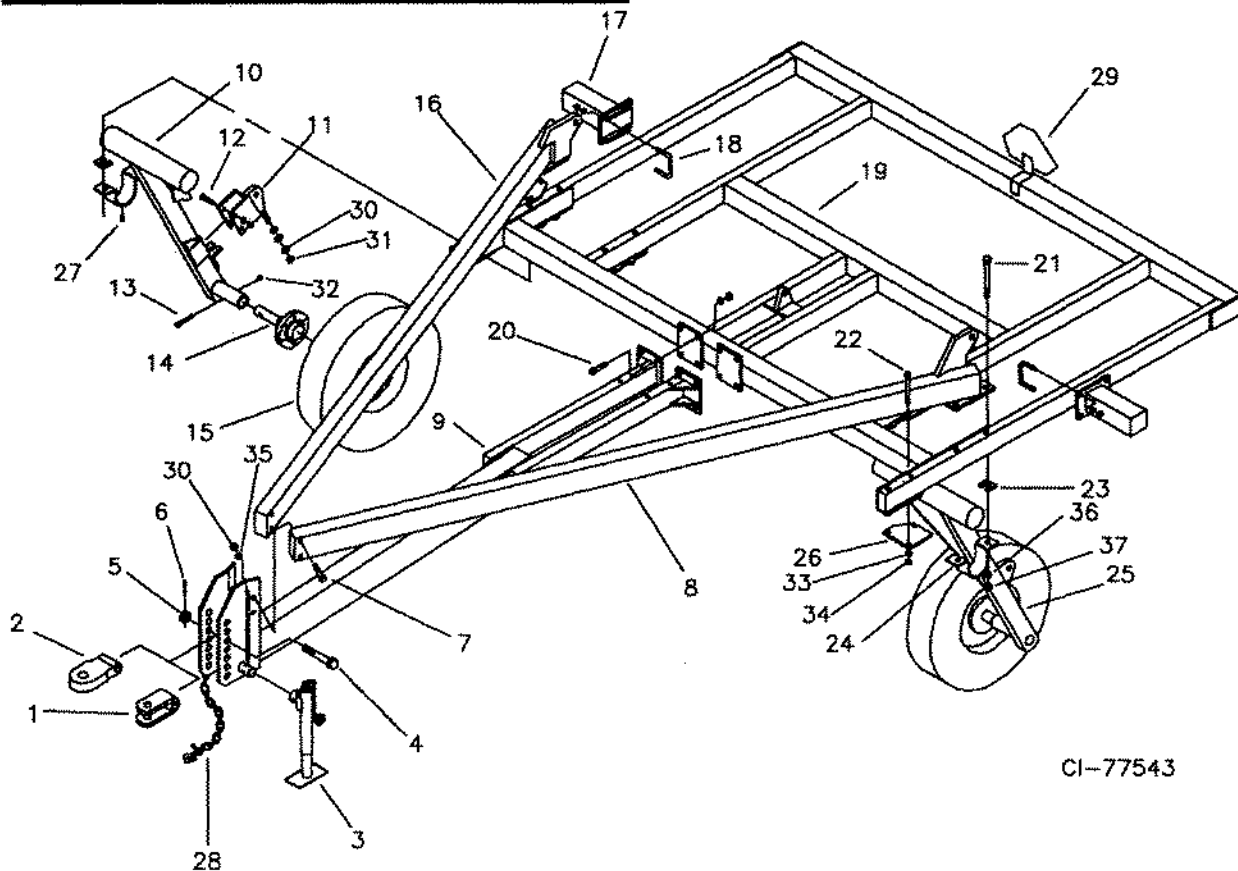

CI-77543

ITEM PART NO. DESCRIPTION

1	11364	CLEVIS HITCH
2	18237	CAST HITCH
3	12796	POLE JACK
4	11638	HITCH BOLT 1-1/4NC X 6-1/2 GR5
5	88350	1-1/4NC SLOTTED NUT
6	88133	COTTER PIN 3/16 X 2
7	88421	BOLT 3/4NC X 4-1/2 GR5
8	41290	LEFT POLE BRACE
9	41289	MAIN HITCH
10	41287	RIGHT MAIN AXLE
11	41301	AXLE ANCHOR
12	88381	BOLT 5/8NC X 4-1/2 GR5
13	88429	BOLT 1/2NF X 3-1/4 GR5
14	14131	2IN HUB & SPINDLE
15	13143	11L X 15 TIRE ASSEMBLY
	11951	11L X 15 6-PLY TIRE
	10498	15 X 8 6 BOLT RIM
	11958	9.5/11L X 15 TUBE
16	41291	RIGHT POLE BRACE
17	29779	STUB
18	88388	U-BOLT 5/8NC X 4 X 3-1/4
19	41286	4411 MAIN FRAME (7 SHANK)

ITEM PART NO. DESCRIPTION

20	88290	BOLT 3/4NC X 2 GR8
21	88436	BOLT 7/8NC X 7 GR8
22	88295	BOLT 5/8NC X 6 GR5
23	10176	AXLE SPACER
24	10399	AXLE CAP
25	41288	LEFT MAIN AXLE
26	41303	POLE BRACE PLATE
27	88263	GREASE FITTING 1/8NPT
28	55174	SAFETY CHAIN ASSEMBLY
29	41345	SMV KIT
30	88110	NUT 3/4NC
31	88131	FLAT WASHER 3/4
32	88304	LOCK NUT 1/2NF
33	88129	LOCK WASHER 5/8
34	88126	NUT 5/8NC
35	88130	LOCK WASHER 3/4
36	88341	LOCK WASHER 7/8
37	88371	NUT 7/8NC

7 & 7-9 CUTTER GANG

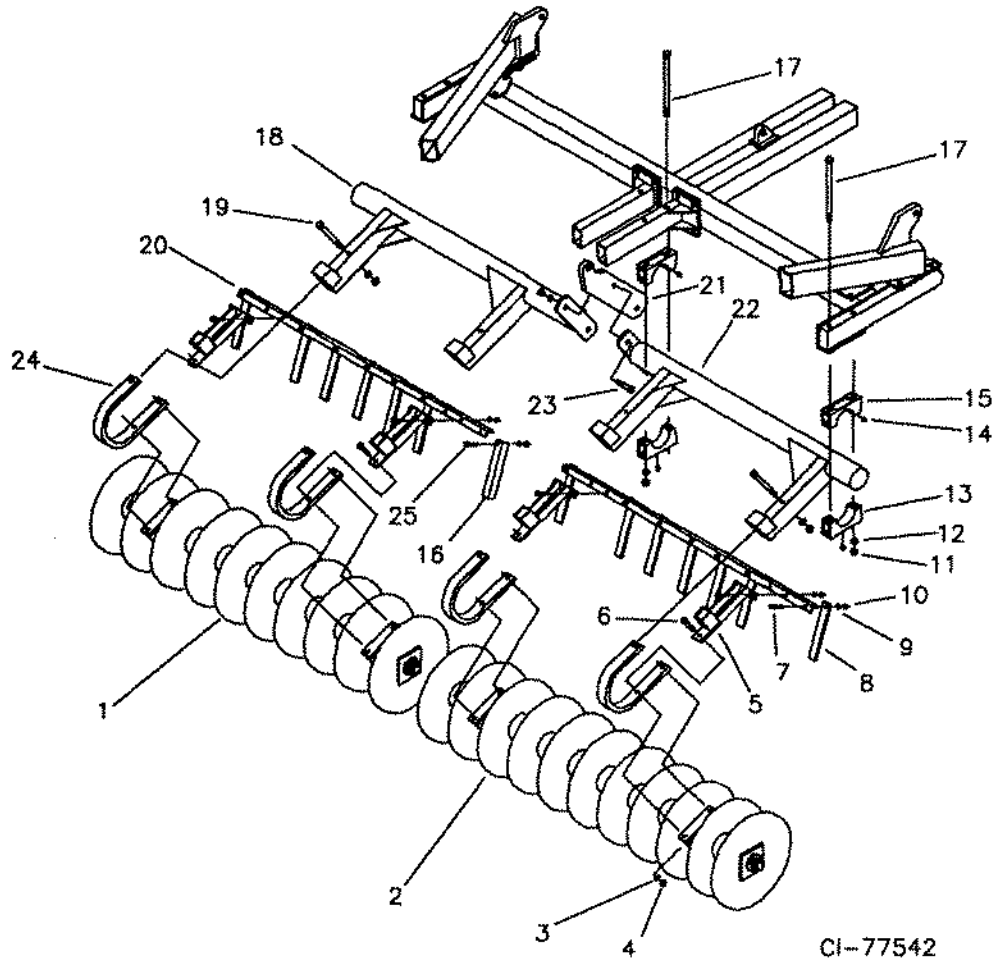

CI-77542

ITEM PARTNO. DESCRIPTION

1	41294	7-BLADE GANG (7 SHANK)
	41295	8-BLADE GANG (9 SHANK)
2	41295	8-BLADE GANG (7 SHANK)
	41296	9-BLADE GANG (9 SHANK)
3	88129	LOCK WASHER 5/8
4	88126	NUT 5/8NC
5	48897	SCRAPER BRACKET
6	88408	BOLT 5/8NC X 3 GR5
7	88475	BOLT 1/2NC X 1-1/2 GR5
8	29749	SCRAPER BAR
9	88303	LOCK WASHER 1/2
10	88104	NUT 1/2NC
11	88110	NUT 3/4NC
12	88130	LOCK WASHER 3/4

ITEM PARTNO. DESCRIPTION

13	34132	LOWER AXLE CLAMP
14	88550	GREASE FITTING 1/4NF
15	34131	TOP AXLE CLAMP
16	47773	CENTER SCRAPER BAR
17	88871	BOLT 3/4NC X 12 GR5
18	41293	RIGHT DISC AXLE
19	88293	BOLT 3/4NC X 6 GR5
20	48368	7-8 SCRAPER BAR (7 SHANK)
	47779	8 BLADE SCRAPER BAR (9 SHANK)
21	49028	DISC ANCHOR
22	41292	LEFT DISC AXLE
23	88291	BOLT 3/4NC X 3 GR5
24	41250	SPRING SHANK
25	88475	BOLT 1/2NC X 1-1/2 GR5

9, 9-11 & 9-13 SHANK MAIN FRAME

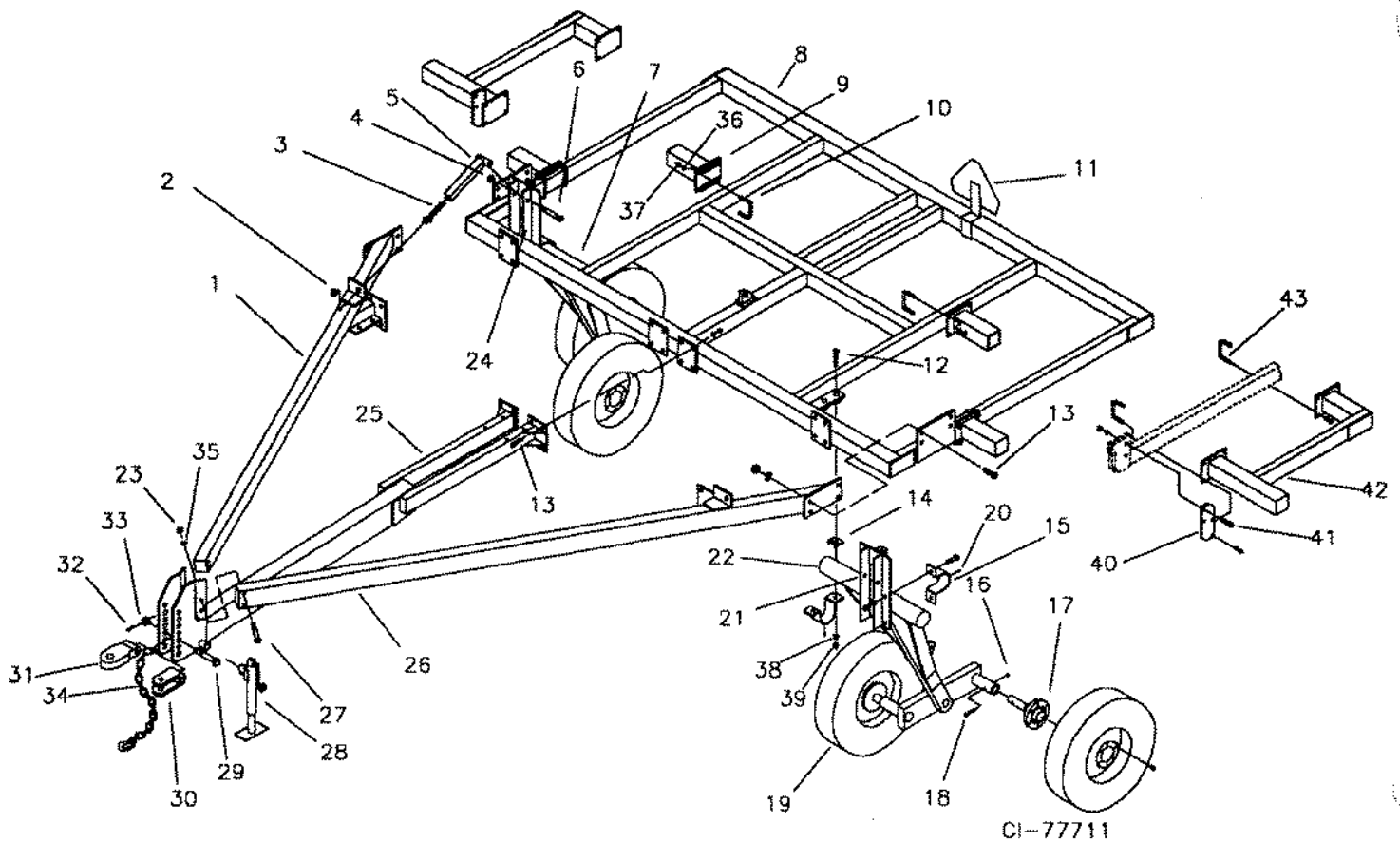

CI-77711

ITEM PART NO. DESCRIPTION

1	42453	RIGHT POLE BRACE
2	88125	NUT 1NC
3	48890	ADJUSTMENT ROD
4	88348	LOCK NUT 1NC
5	29756	TORQUE TUBE
6	88264	BOLT 1NC X 6 GR5
7	29774	RIGHT MAIN AXLE ASSY
8	42466	MAIN FRAME
9	29779	STUB
10	88388	U-BOLT 5/8NC X 4 X 3-1/4
11	41345	SMV KIT
12	88495	BOLT 7/8NC X 2-1/2 GR5
13	88290	BOLT 3/4NC X 2 GR8
14	10176	SPACER
15	10399	AXLE CAP
16	88304	LOCK NUT 1/2NF
17	14131	2" HUB & SPINDLE ASSY
18	88429	BOLT 1/2NF X 3-1/4 GR5
19	11950	WHEEL ASSY 9.5L 15 8PLY
20	88263	GREASE FITTING 1/8 NPT
21	29724	9.3 MAST
22	29773	LEFT MAIN AXLE ASSY

ITEM PART NO. DESCRIPTION

23	88110	NUT 3/4NC
24	29721	8.0 MAST
25	42465	POLE
26	42452	LEFT POLE BRACE
27	88421	BOLT 3/4NC X 4-1/2 GR5
28	12796	POLE JACK
29	11638	HITCH BOLT
30	11364	CLEVIS HITCH
31	18237	CAST HITCH
32	88133	COTTER PIN 3/16 X 2
33	33850	SLOTTED NUT 1-1/4NC
34	55174	CHAIN ASSEMBLY
35	88130	LOCK WASHER 3/4
36	88129	LOCK WASHER 5/8
37	88126	NUT 5/8NC
38	88341	LOCK WASHER 7/8
39	88371	NUT 7/8NC
40	54968	TIE PLATE
41	88291	BOLT 3/4NC X 3 GR5
42	54967	2 SHANK STUB
43	88388	U-BOLT 5/8NC X 4 X 3-1/4

9, 9-11 & 9-13 CUTTER GANG

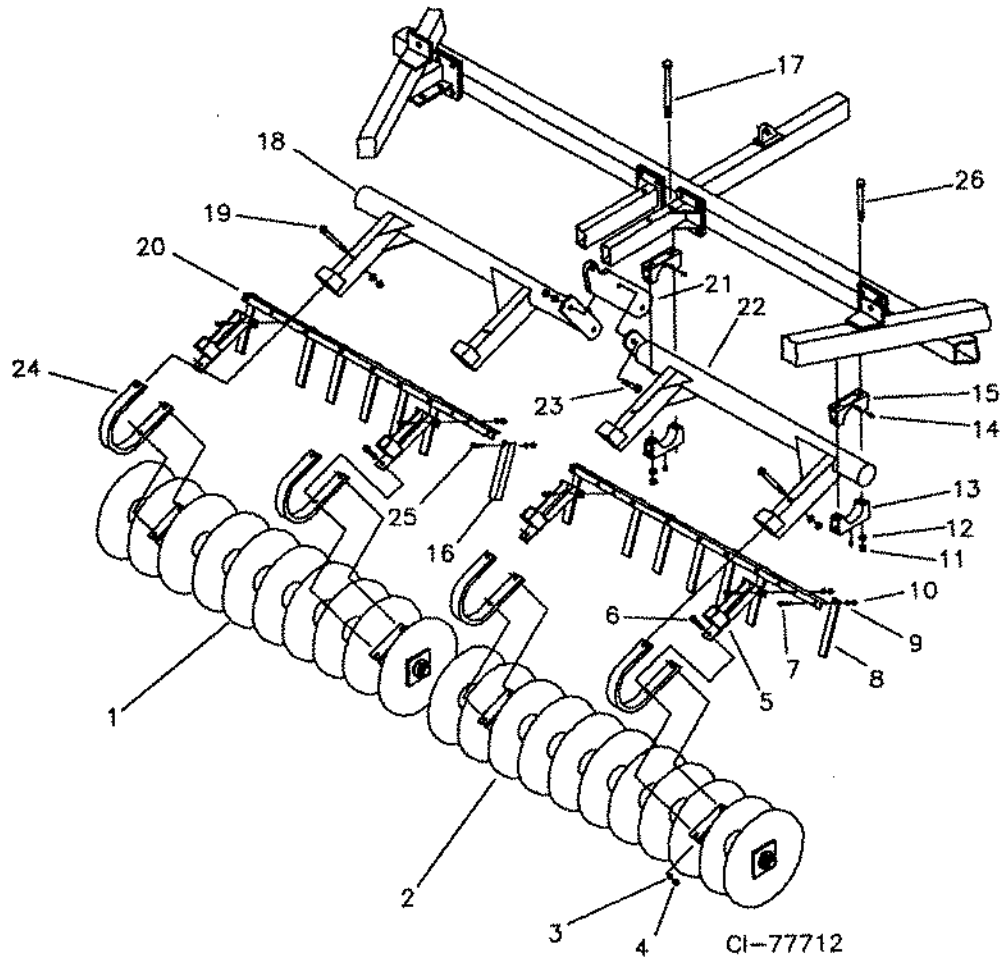

ITEM PART NO. DESCRIPTION

1	29782	9-BLADE GANG (9 SHANK)
	29781	10-BLADE GANG (11 SHANK)
	54957	12-BLADE GANG (13 SHANK)
2	29781	10-BLADE GANG (9 SHANK)
	40403	11-BLADE GANG (11 SHANK)
	54958	13-BLADE GANG (13 SHANK)
3	88129	LOCK WASHER 5/8
4	88126	NUT 5/8NC
5	48897	SCRAPER BRACKET
6	88408	BOLT 5/8NC x 3 GR5
7	88475	BOLT 1/2NC x 1-1/2 GR5
8	29749	SCRAPER BAR
9	88303	LOCK WASHER 1/2
10	88104	NUT 1/2NC
11	88110	NUT 3/4NC
12	88130	LOCK WASHER 3/4
13	34132	LOWER AXLE CLAMP
14	88550	GREASE FITTING 1/4NF

ITEM PART NO. DESCRIPTION

15	34131	TOP AXLE CLAMP
16	47773	CENTER SCRAPER BAR
17	88871	BOLT 3/4NC x 12 GR5
18	42500	RIGHT DISK AXLE (9-11 SHANK)
	54963	RIGHT DISK AXLE (13 SHANK)
19	88293	BOLT 3/4NC x 6 GR5
20	47770	10 BLADE SCRAPER BAR (11 SHANK)
	48369	9-10 SCRAPER BAR (9 SHANK)
	54964	12 BLADE SCRAPER BAR (13 SHANK)
21	49028	DISK ANCHOR
22	42499	LEFT DISK AXLE (9-11 SHANK)
	54962	LEFT DISK AXLE (13 SHANK)
23	88291	BOLT 3/4NC x 3 GR5
24	41250	SPRING SHANK
25	88475	BOLT 1/2NC x 1-1/2 GR5
26	88403	BOLT 3/4NC x 8 GR5

CUTTER GANG

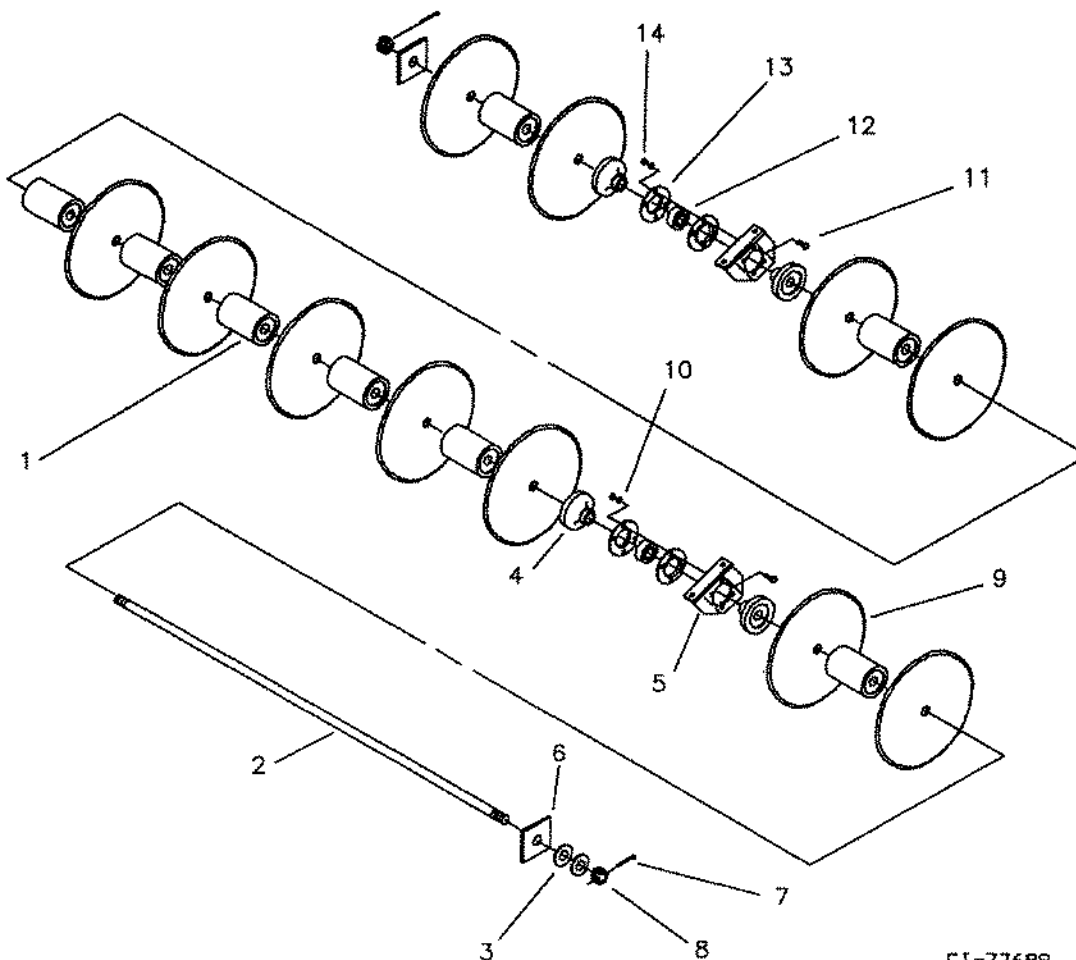

CI-77688

ITEM PART NO. DESCRIPTION

<u>7-9 SHANK MODELS</u>	
41294	7-BLADE GANG
41295	8-BLADE GANG
41296	9-BLADE GANG
<u>9-11 SHANK MODELS</u>	
29782	9-BLADE GANG
29781	10-BLADE GANG
40403	11-BLADE GANG (SHOWN)
<u>13 SHANK MODELS</u>	
54957	12 BLADE GANG
54958	13-BLADE GANG
1	33994 FULL SPOOL
2	34098 49.4IN ARBOR BOLT (7 BLD)
	34096 56.9IN ARBOR BOLT (8 BLD)
	34101 64.4IN ARBOR BOLT (9 BLD)
	34100 71.9IN ARBOR BOLT (10 BLD)
	40405 79.4IN ARBOR BOLT (11 BLD)
	54960 86.9IN ARBOR BOLT (12 BLD)
	54961 94.4IN ARBOR BOLT (13 BLD)

ITEM PART NO. DESCRIPTION

3	88616	FLAT WASHER 1-1/2
4	33996	HALF SPOOL
5	29757	BEARING HANGER
6	34097	END PLATE
7	88603	COTTER PIN 1/4 x 3
8	88614	SLOTTED NUT 1-1/2NC
9	34001	20IN DIA COULTER BLADE
10	88303	LOCK WASHER 1/2
11	88873	CARRIAGE BOLT 1/2NCx1-1/2
12	34002	BEARING
13	34003	BEARING FLANGETTE
14	88104	NUT 1/2NC

SHANK ASSEMBLY

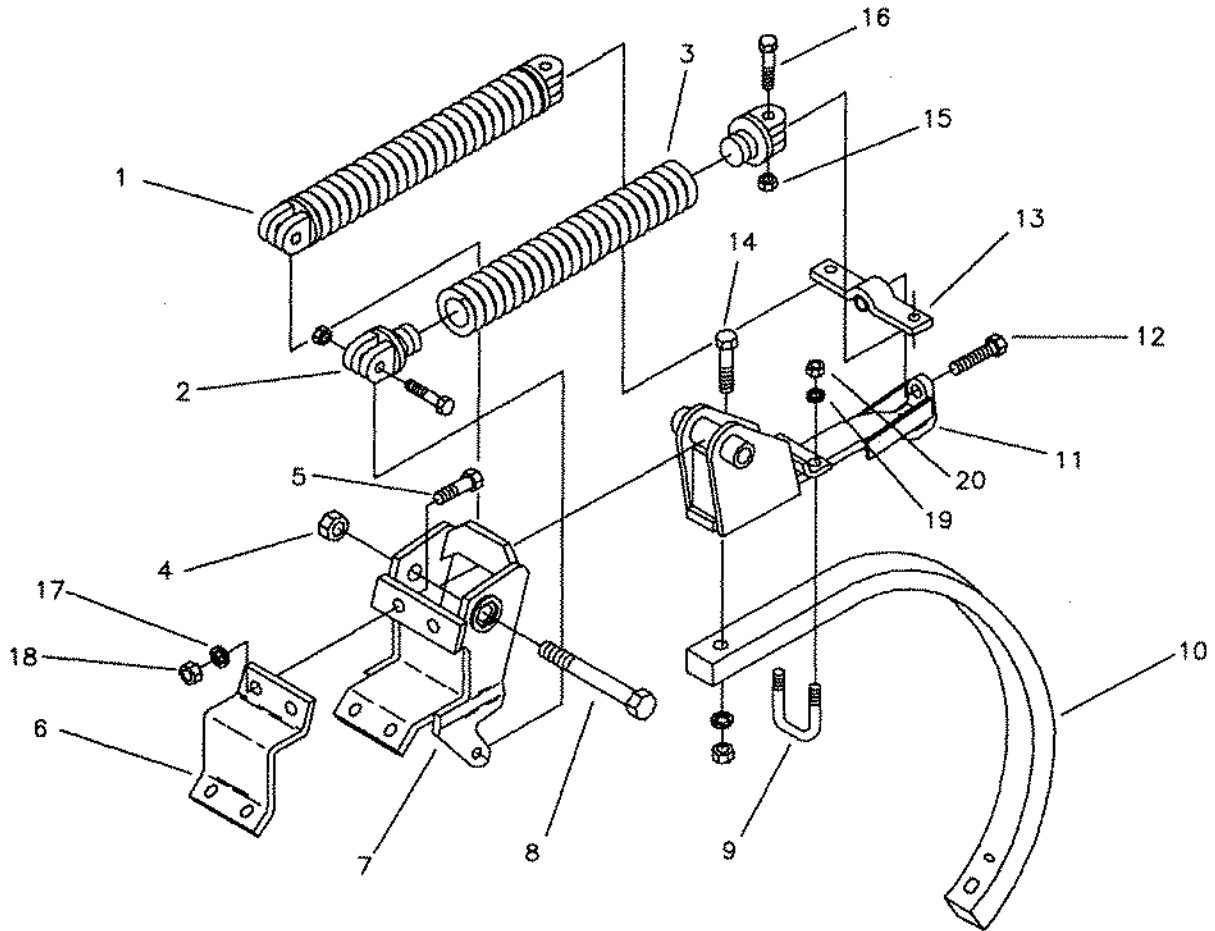

CI-77534

ITEM PART NO. DESCRIPTION

	54702	SHANK ASSEMBLY (COMPLETE W/MTG HDWE)
1	54704	SPRING & PLUG ASSEMBLY (INCLUDES ITEMS 2&3)
2	27261	SPRING CASTING
3	54703	CHISEL SPRING 5/8
4	88169	LOCK NUT 1NF
5	88290	BOLT 3/4NC X 2 GR8
6	54707	SHANK PLATE
7	54706	SHANK BRACKET
8	14987	PIVOT BOLT 1NF X 7 GR5
9	88441	U-BOLT 5/8NC X 2 X 3-1/4

ITEM PART NO. DESCRIPTION

10	54705	HD 32IN SHANK
11	54449	SHANK HOLDER
12	29787	ADJUSTMENT BOLT 3/4NC x 3 GR8
13	29808	SPRING ADJUST ASSEMBLY
14	88955	BOLT 3/4NC X 3 GR5
15	88369	LOCK NUT 5/8NC
16	29788	YOKE BOLT 5/8NC X 2-1/2 GR5
17	88130	LOCK WASHER 3/4
18	89080	NUT 3/4NC
19	88129	LOCK WASHER 5/8
20	88126	NUT 5/8NC

HD RIGID SHANK ASSEMBLY

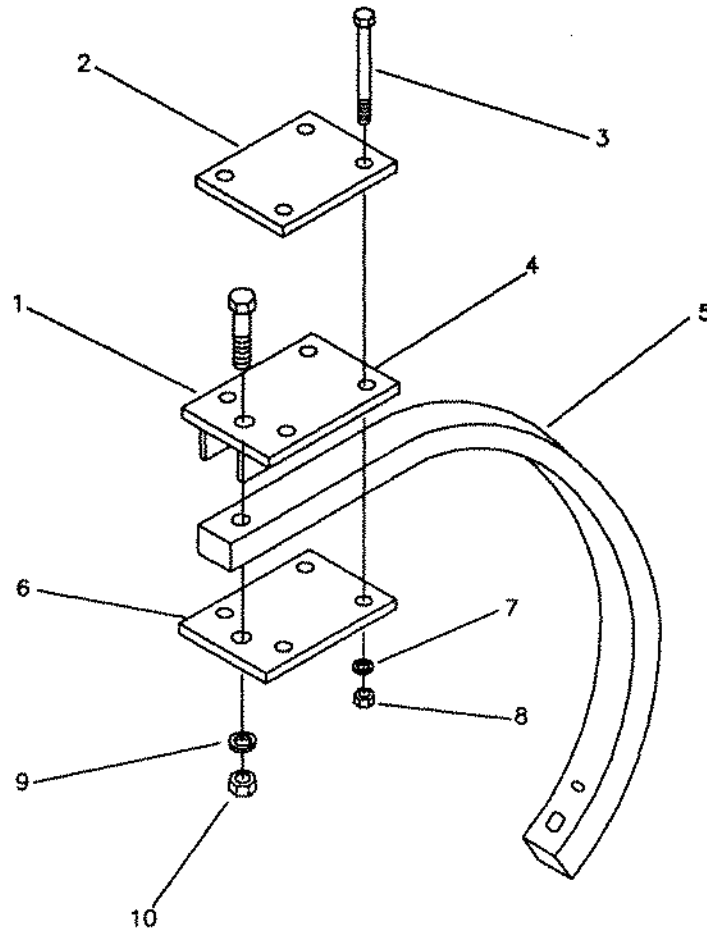

CI-78192

ITEM PART NO. DESCRIPTION

	21499	HD RIGID SHANK ASSEMBLY (EXCLUDES 2, 3, 7 & 8)
1	88111	BOLT 3/4NC X 3-1/2 GR5
2	12751	FRAME PLATE
3	88476	BOLT 5/8NC X 8 GR5
4	19919	RIGID SHANK HOLDER

ITEM PART NO. DESCRIPTION

5	54705	HD 32IN SHANK
6	19920	SHANK HOLDER PLATE
7	88129	LOCK WASHER 5/8
8	88126	NUT 5/8NC
9	89080	NUT 3/4NC
10	88130	LOCK WASHER 3/4

SPIKES & TWISTED MOLDBOARDS

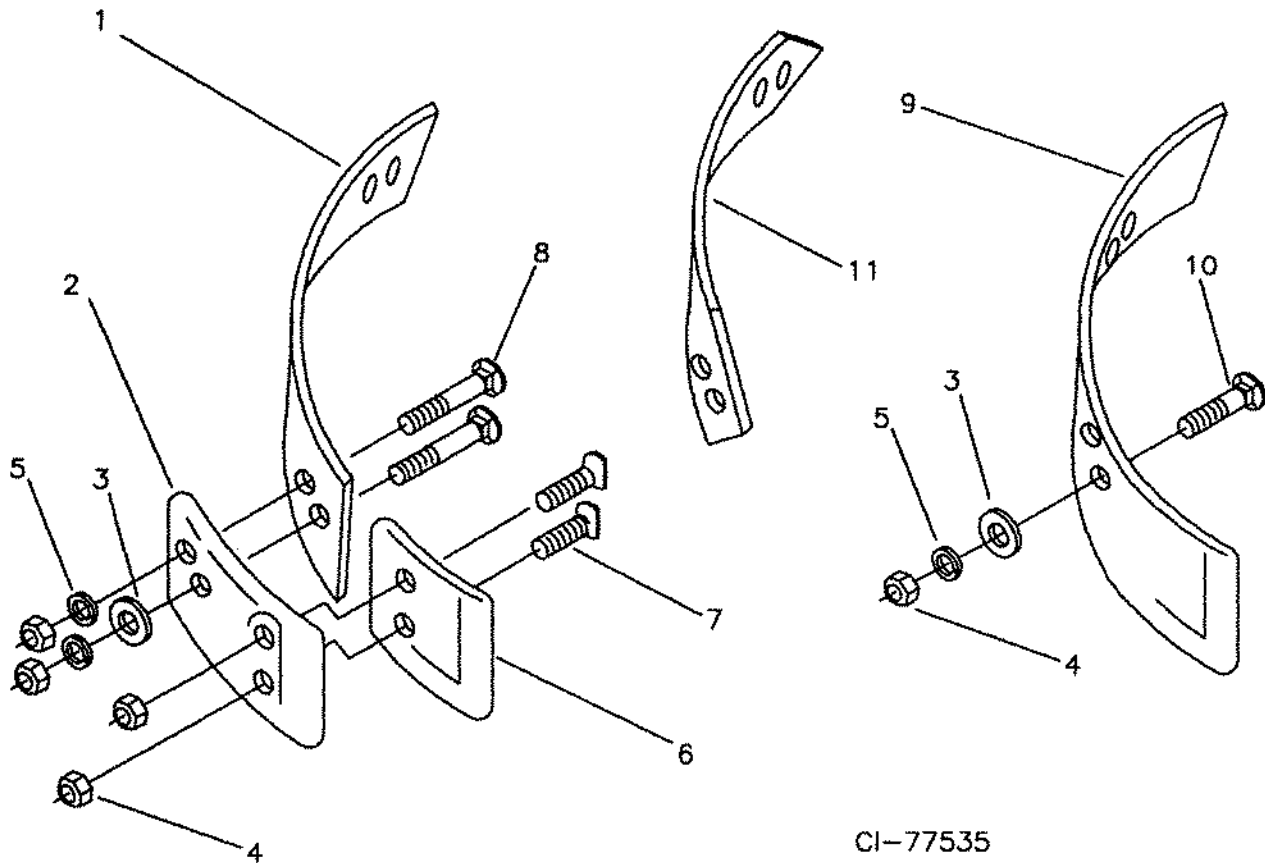

CI-77535

ITEM	PART NO.	DESCRIPTION
	19391	RIGHT 3PC MOLDBOARD ASSEMBLY(SHOWN) (INCLUDES ITEMS 1-8)
	19392	LEFT 3PC MOLDBOARD ASSEMBLY (INCLUDES ITEMS 1-8)
1	19393	LEFT MOLDBOARD
	19394	RIGHT MOLDBOARD (SHOWN)
2	19397	LEFT FROG
	19398	RIGHT FROG (SHOWN)
3	88347	FLAT WASHER 1/2
4	88346	NUT 1/2NC
5	88303	LOCK WASHER 1/2
6	19395	LEFT POINT RIGHT POINT (SHOWN)
7	34077	CLIPPED HEAD BOLT
8	88497	PLOW BOLT 1/2NC X 3-1/4 GR5

ITEM	PART NO.	DESCRIPTION
9	34110	LEFT 1PC MOLDBOARD
	34111	RIGHT 1PC MOLDBOARD (SHOWN)
	33984	TWISTED SPIKE 3/8 X 4 X 22 LEFT (WITH HARDWARE)
	33985	TWISTED SPIKE 3/8 X 4 X 22 RIGHT (WITH HARDWARE)
10	88384	PLOW BOLT 1/2NC X 2-1/2
11	12695	SPIKE 5/8 X 2 X 15
	13392	TWISTED SPIKE 3/8 X 3 X 22 LEFT
	13393	TWISTED SPIKE 3/8 X 3 X 22 RIGHT (SHOWN)

SPIKE MOUNTING HARDWARE

14691	HARDWARE KIT (BOX OF 50) FOR 13392 & 13393
14692	HARDWARE KIT (BOX OF 50) FOR 12695

7 & 7-9 CUTTER CHISEL HYDRAULIC

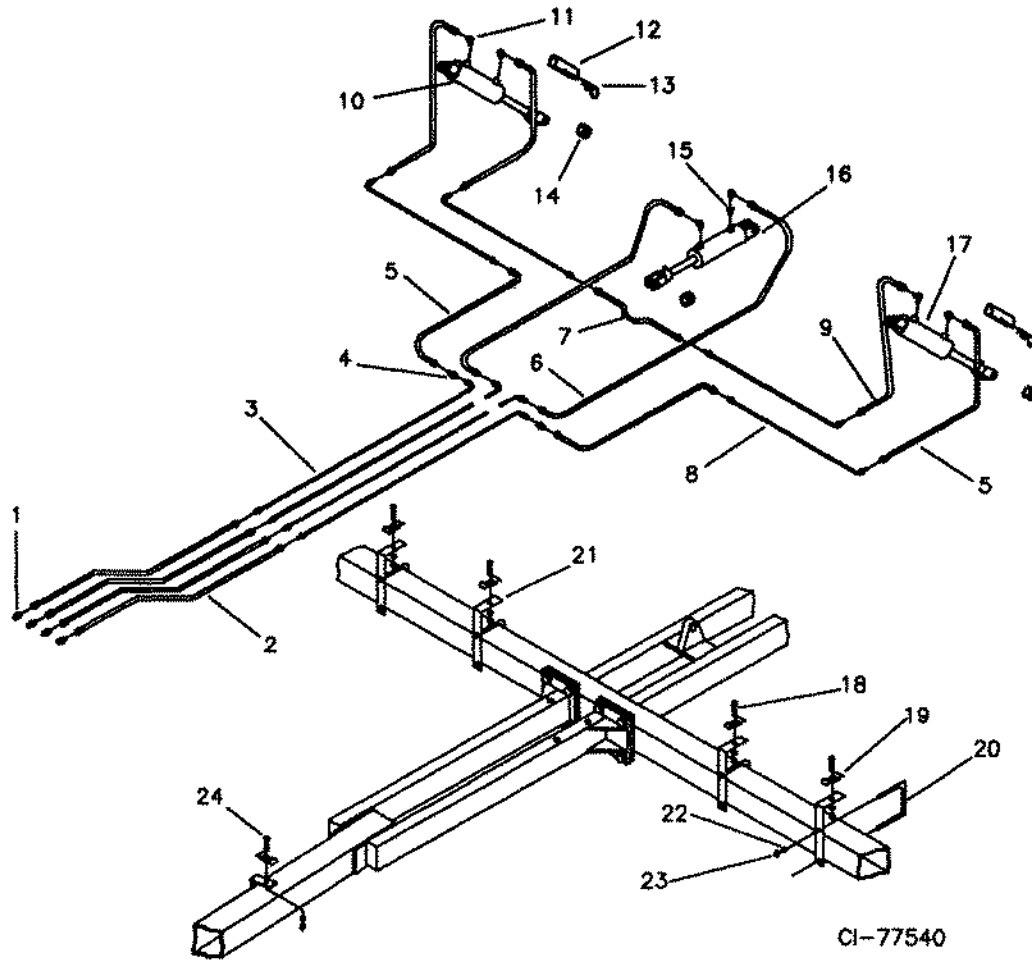

ITEM PARTNO. DESCRIPTION

1	13234	ADAPTER 1/2NPT-3/4JIC
2	13266	HOSE 3/8 X 60IN
3	13257	TUBE 1/2 X 75+2IN
4	13239	UNION 3/4JIC
5	13263	HOSE 3/8 X 36IN
6	13264	HOSE 3/8 X 48IN
7	15995	HOSE 3/8 X 24IN (M-M)
8	21021	TUBE 1/2 X 36+2IN
9	13260	HOSE 3/8 X 24IN
10	42579	TBP CYLINDER 4 X 8
11	13236	PORT ELBOW 1/2 NPT
12	13681	LOCK CHANNEL 1-1/2

ITEM PARTNO. DESCRIPTION

13	42721	SPRING LOCK PIN 1/4 X 5
14	15113	ADD-ON STOP COLLAR
15	24627	RESTRICTOR 1/2NPT (1/16)
16	13572	SCREW STOP CYLINDER 4 X 8
17	42580	TBP CYLINDER 4 X 9.3
18	88157	BOLT 3/8NC X 1
19	13215	TUBE CLAMP
20	88385	U-BOLT 3/8NC X 4 X 4-3/4
21	13270	HYDRAULIC TUBE BRACKET
22	88362	LOCK WASHER 3/8
23	88103	NUT 3/8NC
24	88553	BOLT 3/8NC X 1-1/2

9, 9-11 & 9-13 CUTTER CHISEL HYDRAULICS

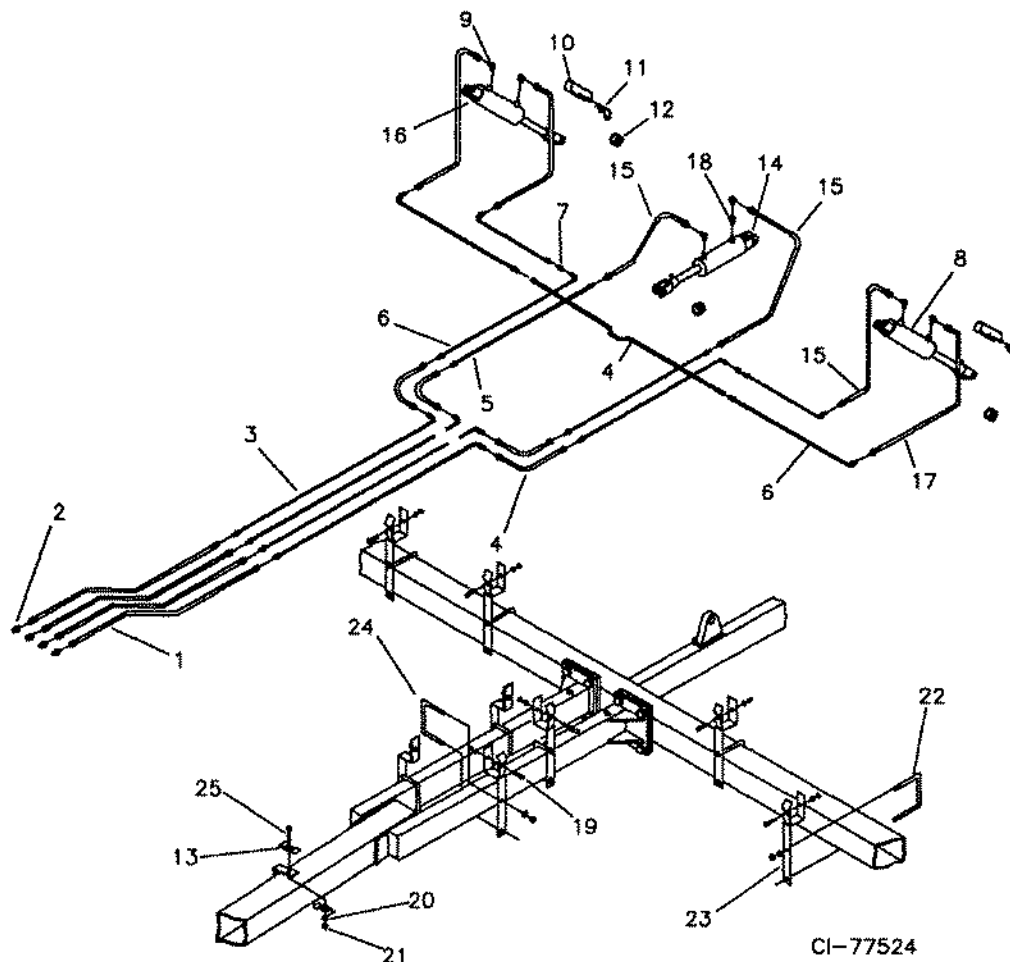

ITEM PARTNO. DESCRIPTION

1	13266	HOSE 3/8 X 60IN
2	13234	ADAPTER 1/2NPT-3/4JIC
3	13258	TUBE 1/2 X 60+2
4	15995	HOSE 3/8 X 24IN (M-M)
5	13287	TUBE 1/2 X 38IN
6	21021	TUBE 1/2 X 36+2IN
7	13239	UNION 3/4JIC
8	42580	TBP CYLINDER 4 X 9.3
9	13236	PORT ELBOW 1/2NPT
10	13681	CHANNEL LOCK 1-1/2
11	42721	SPRING LOCK PIN 1/4X5
12	15113	ADD-ON STOP COLLAR
13	13215	TUBE CLAMP

ITEM PARTNO. DESCRIPTION

14	13572	SCREW STOP CYLINDER 4X8
15	13260	HOSE 3/8 X 24IN
16	42579	TBP CYLINDER 4 X 8
17	13263	HOSE 3/8 X 36IN
18	24627	1/2NPT RESTRICTOR (1/16)
19	88157	BOLT 3/8NC X 1
20	88362	LOCK WASHER 3/8
21	88103	NUT 3/8NC
22	88385	U-BOLT 3/8NC X 4 X 4-3/4
23	13277	TUBE BRACKET
24	88515	U-BOLT 3/8NC X 4 X 2-3/4
25	88553	BOLT 3/8NC X 1-1/2 GR5

2IN HUB & SPINDLE

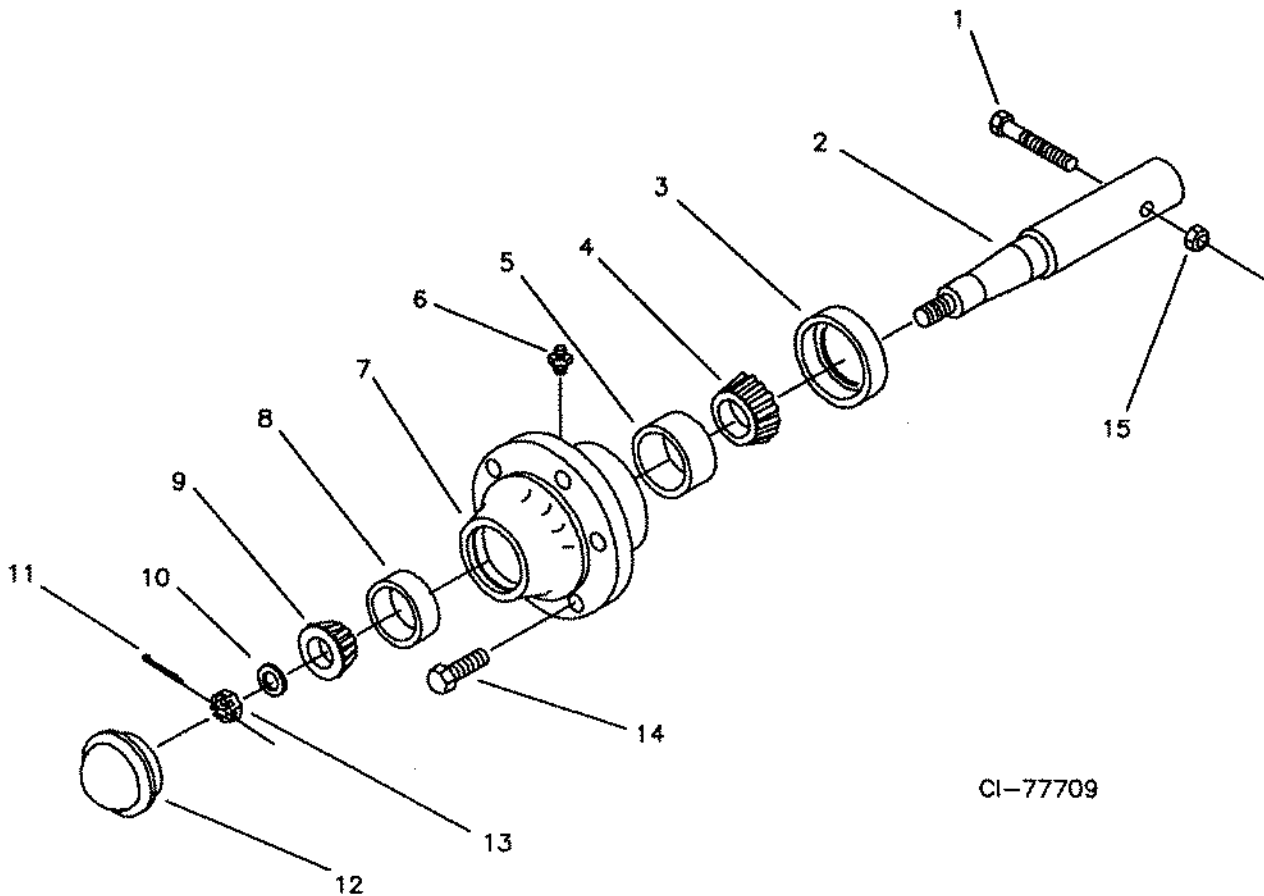

CI-77709

ITEM	PART NO.	DESCRIPTION
	14131	2IN HUB & SPINDLE ASSY (INCLUDES ITEMS 2-14)
1	88429	BOLT 1/2NF X 3-1/4 GR5
2	14251	SPINDLE
3	14247	SEAL
4	14248	INNER BEARING CONE
5	14249	INNER BEARING CUP
6	88263	GREASE FITTING 1/8NPT
7	24097	2IN PRESSED HUB (INCLUDES ITEMS 5, 6 & 8)

ITEM	PART NO.	DESCRIPTION
8	10344	OUTER BEARING CUP
9	10345	OUTER BEARING CONE
10	16094	SPINDLE WASHER 7/8
11	88301	COTTER PIN 3/16 X 1-1/2
12	11381	DUST CAP
13	88340	SLOTTED NUT 7/8NF
14	88142	WHEEL BOLT 1/2 NF X 1
15	88304	LOCK NUT 1/2NF

2IN WALKING TANDEM

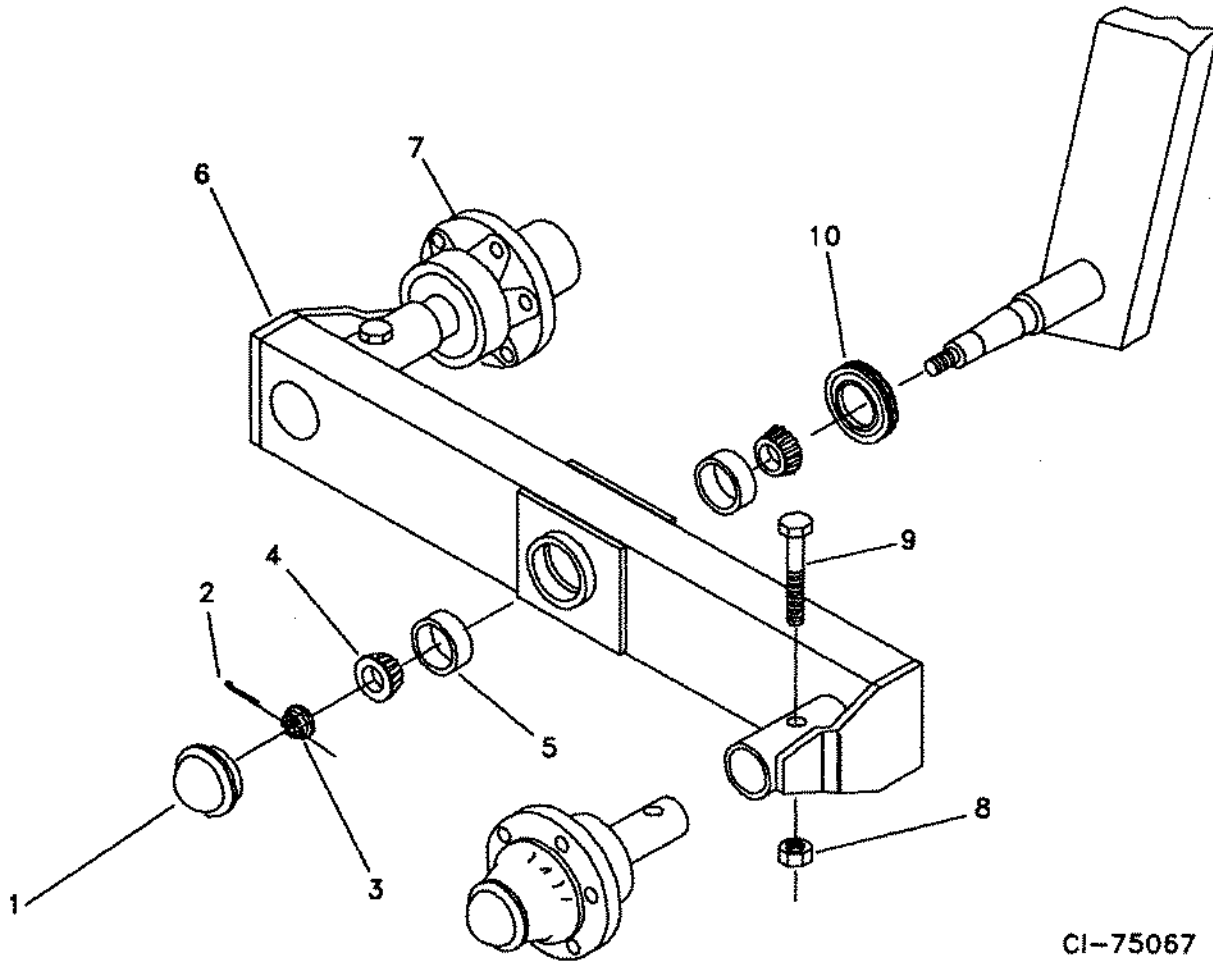

CI-75067

ITEM PART NO. DESCRIPTION

1	12206	DUST CAP
2	88133	COTTER PIN 3/16 X 2
3	12712	WALKING TANDEM NUT ASSY
4	12103	BEARING CONE
5	12104	BEARING CUP

ITEM PART NO. DESCRIPTION

6	29703	WALKING TANDEM ASSY 2X22
7	14131	2IN HUB & SPINDLE
8	88304	LOCK NUT 1/2NF
9	88429	BOLT 1/2NF X 3-1/4 GR5
10	23733	2-1/4ID SEAL KIT
	26120	SEAL
	76235	TRIPLE LIP SEAL ASSEMBLY
		INSTRUCTION

4 X 8 SCREW STOP CYLINDERS SERIES RB & SERIES I

NOTE: SERIES REFERS TO FIRST DIGIT OF SERIAL NUMBER.

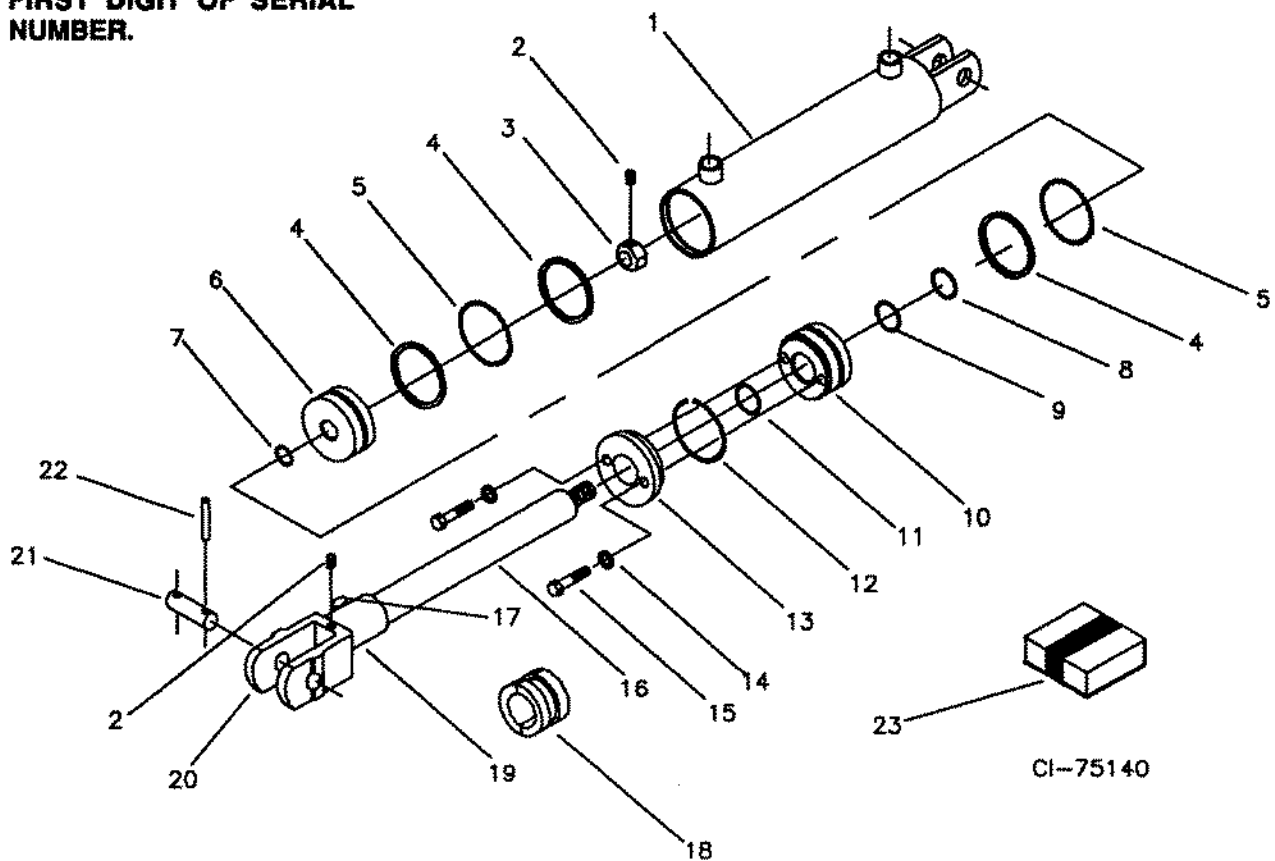

ITEM PART NO. DESCRIPTION

	51227	4x8 SS CYLINDER SERIES RB
	13572	4x8 SS CYLINDER SERIES I
1	12284	CYLINDER TUBE ASSY
2	88706	SET SCREW 5/16NC X 5/16
3	14824	PISTON LOCK NUT
4	12289	4IN BACK-UP WASHER
5	12291	4IN O-RING
6	12282	4IN PISTON
7	12290	1IN O-RING
8	42570	ROD SEAL (SERIES RB)
	14902	1-1/2IN O-RING (SERIES I)
9	14903	1-1/2IN BACK-UP WASHER (SERIES I)
10	42576	END GLAND (SERIES RB)
	12283	4IN CYLINDER GLAND (SERIES I)

ITEM PART NO. DESCRIPTION

11	42571	1-1/2 CANNED WIPER (SERIES RB)
	12288	ROD WIPER (SERIES I)
12	12286	4IN SNAP RING
13	13851	STOP PLATE
14	88362	LOCK WASHER 3/8
15	88553	BOLT 3/8NC X 1-1/2 GR5
16	13569	CYLINDER ROD
17	88387	THUMBSCREW 5/16NC X 5/16
18	15113	ADD-ON STOP COLLAR
19	13570	SCREW STOP COLLAR
20	14822	END YOKE
21	42473	CYLINDER PIN 1 X 3-1/8
22	42484	1/4 X 2-1/4 SPRING LOCK PIN
	42505	CYLINDER PIN KIT (INCLUDES ITEMS 21 & 22)
23	51212	SEAL KIT (SERIES RB)
	14907	SEAL KIT (SERIES I)

4 X 8 TOP BY-PASS CYLINDERS SERIES PX & SERIES PB

NOTE: SERIES REFERS TO
FIRST TWO DIGITS IN
SERIAL NUMBER.

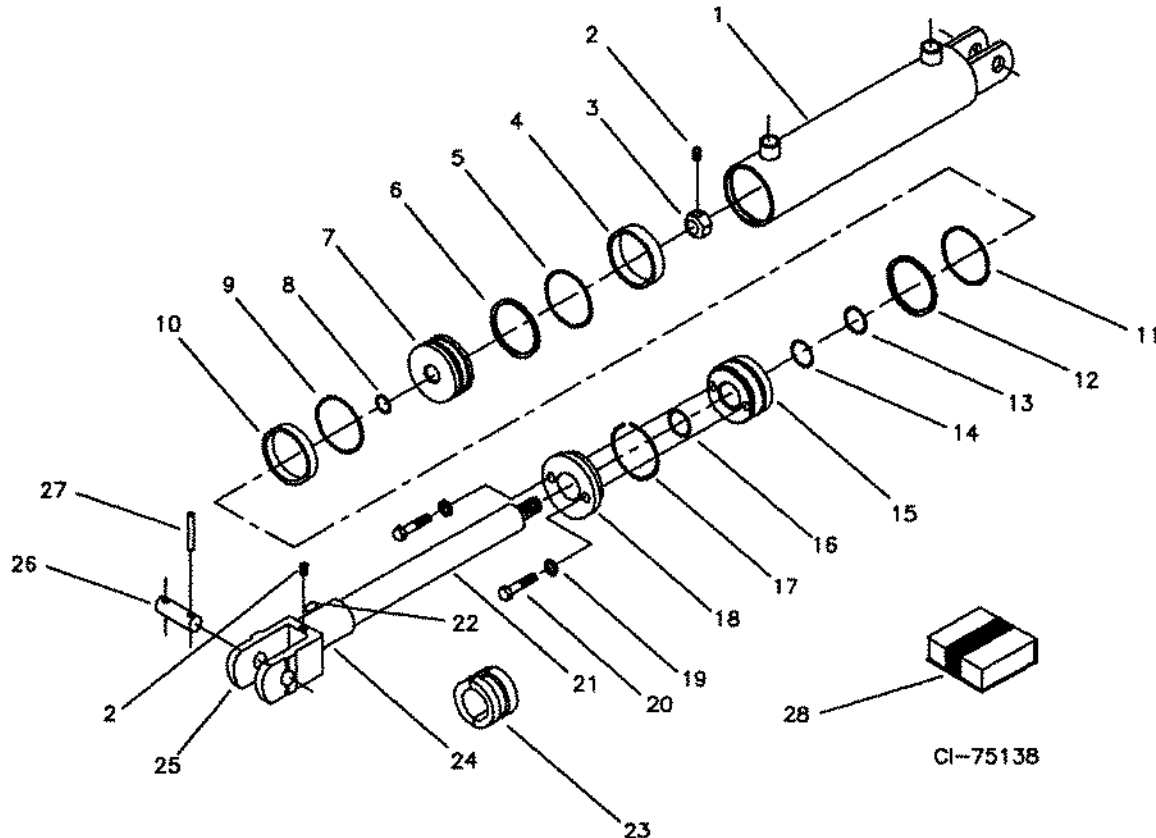

ITEM PART NO. DESCRIPTION

	42579	4 X 8 TBP CYLINDER SERIES PX
	14523	4 X 8 TBP CYLINDER SERIES PB
1	42573	CYLINDER TUBE ASSY
	14525	CYLINDER TUBE ASSY
2	88706	SET SCREW 5/16NC X 5/16
3	14824	PISTON LOCK NUT
4	14534	4IN WEAR RING (SERIES PB)
5	42569	O-RING (SERIES PX)
6	12289	4IN BACK-UP WASHER (SERIES PX)
7	42577	TOP BY-PASS PISTON (SERIES PX)
	14527	TOP BY-PASS PISTON (SERIES PB)
8	12290	SHAFT SEAL
9	12291	PISTON SEAL 4IN (SERIES PX)
	21097	4IN O-RING(SERIES PB)
10	21096	4IN GLIDE RING(SERIES PB)
11	12291	4IN PISTON SEAL
12	12289	4IN BACK-UP WASHER

ITEM PART NO. DESCRIPTION

13	42570	ROD SEAL (SERIES PX)
	14902	1-1/2 O-RING (SERIES PB)
14	14903	1-1/2IN BACK-UP WASHER (SERIES PB)
15	42576	END GLAND (SERIES PX)
	12283	END GLAND (SERIES PB)
16	42571	1-1/2 CANNED WIPER(SERIES PX)
	12288	ROD WIPER (SERIES PB)
17	12286	4IN SNAP RING
18	13851	STOP PLATE 4 X 8
19	88362	LOCK WASHER 3/8
20	88553	BOLT 3/8NC X 1-1/2 GR5
21	13569	CYLINDER ROD
22	88387	3/8NC X 1/2 THUMB SCREW
23	15113	ADD-ON STOP COLLAR
24	13570	SCREW STOP COLLAR
25	14822	ADJUSTABLE END YOKE
26	42473	CYLINDER PIN 1 X 3-1/8
27	42484	SPRING LOCK PIN 1/4 X 4-3/4
	42505	CYLINDER PIN KIT (INCLUDES ITEMS 26 & 27)
28	42664	SEAL KIT (SERIES PX)
	14906	SEAL KIT (SERIES PB)

4 X 9.3 TOP BY-PASS CYLINDERS SERIES PY & SERIES PE

NOTE: SERIES REFERS TO FIRST TWO DIGITS IN SERIAL NUMBER.

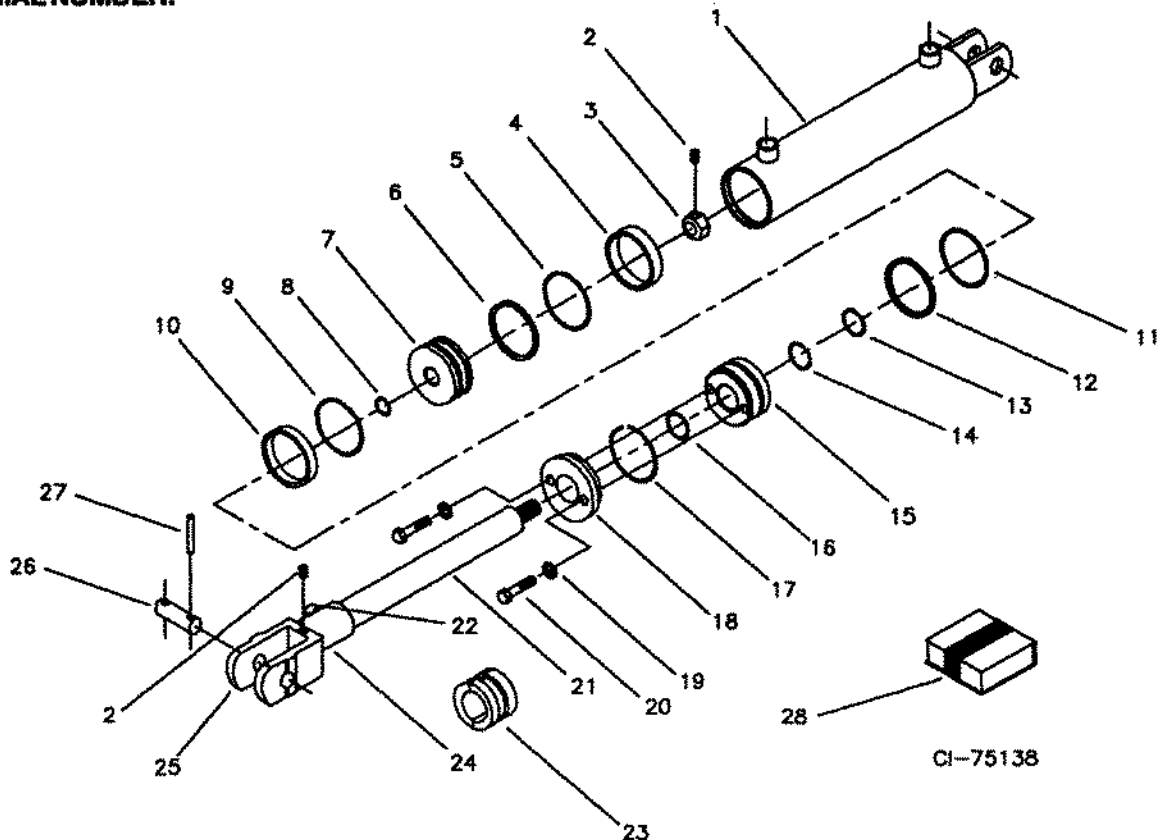

ITEM PART NO. DESCRIPTION

	42580	4 X 9.3 TBP CYLINDER SERIES PY
	16211	4 X 9.3 TBP CYLINDER SERIES PE
1	42574	CYLINDER TUBE ASSY
	16220	CYLINDER TUBE ASSY
2	88706	SET SCREW 5/16NC X 5/16
3	14824	PISTON LOCK NUT
4	14534	4IN WEAR RING (SERIES PE)
5	42569	O-RING (SERIES PY)
6	12289	4IN BACK-UP WASHER (SERIES PY)
7	42577	TOP BY-PASS PISTON (SERIES PY)
	14527	TOP BY-PASS PISTON (SERIES PE)
8	12290	SHAFT SEAL
9	12291	4IN PISTON SEAL (SERIES PY)
	21097	4IN O-RING(SERIES PE)
10	21096	4IN GLIDE RING(SERIES PE)
11	12291	4IN PISTON SEAL
12	12289	4IN BACK-UP WASHER

ITEM PART NO. DESCRIPTION

13	42570	ROD SEAL (SERIES PY)
	14902	1-1/2 O-RING (SERIES PE)
14	14903	1-1/2IN BACK-UP WASHER (SERIES PE)
15	42576	END GLAND (SERIES PY)
	12283	END GLAND (SERIES PE)
16	42571	1-1/2 CANNED WIPER(SERIES PY)
	12288	ROD WIPER (SERIES PE)
17	12286	4IN SNAP RING
18	13851	STOP PLATE 4 X 8
19	88362	LOCK WASHER 3/8
20	88553	BOLT 3/8NC X 1-1/2 GR5
21	16221	CYLINDER ROD
22	88387	3/8NC X 1/2 THUMB SCREW
23	15113	ADD-ON STOP COLLAR
24	13570	SCREW STOP COLLAR
25	14822	ADJUSTABLE END YOKE
26	42473	CYLINDER PIN 1 X 3-1/8
27	42484	SPRING LOCK PIN 1/4 X 4-3/4
	42505	CYLINDER PIN KIT (INCLUDES ITEMS 26 & 27)
28	42664	SEAL KIT (SERIES PY)
	14906	SEAL KIT (SERIES PE)

WIL-RICH
4411 CUTTER CHISEL

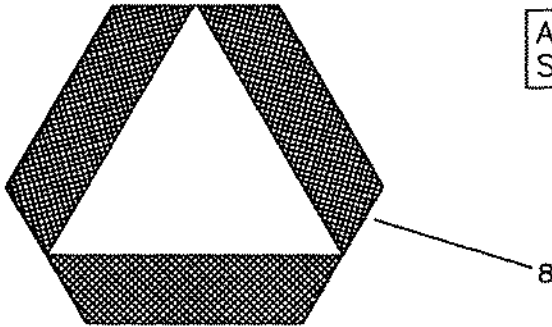
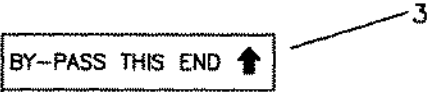

CI-77706

ITEM PARTNO.	DESCRIPTION
1 18298	WIL-RICH LOGO 3/4 X 9
18299	WIL-RICH LOGO 1-1/8 X 13
18300	WIL-RICH LOGO 1-3/4 X 20
24134	WIL-RICH LOGO 3-5/8 X 40
2 29995	4411 CUTTER CHISEL DECAL

ITEM PARTNO.	DESCRIPTION
3 20339	BYPASS DECAL
4 23325	CAUTION DECAL
5 20119	SCREW STOP ADJUST DECAL
6 74086	OPERATOR'S MANUAL
7 74062	ASSEMBLY MANUAL
8 41345	SMV KIT

9 & 9-11 SHANK MAIN FRAME HITCH

NON CURRENT

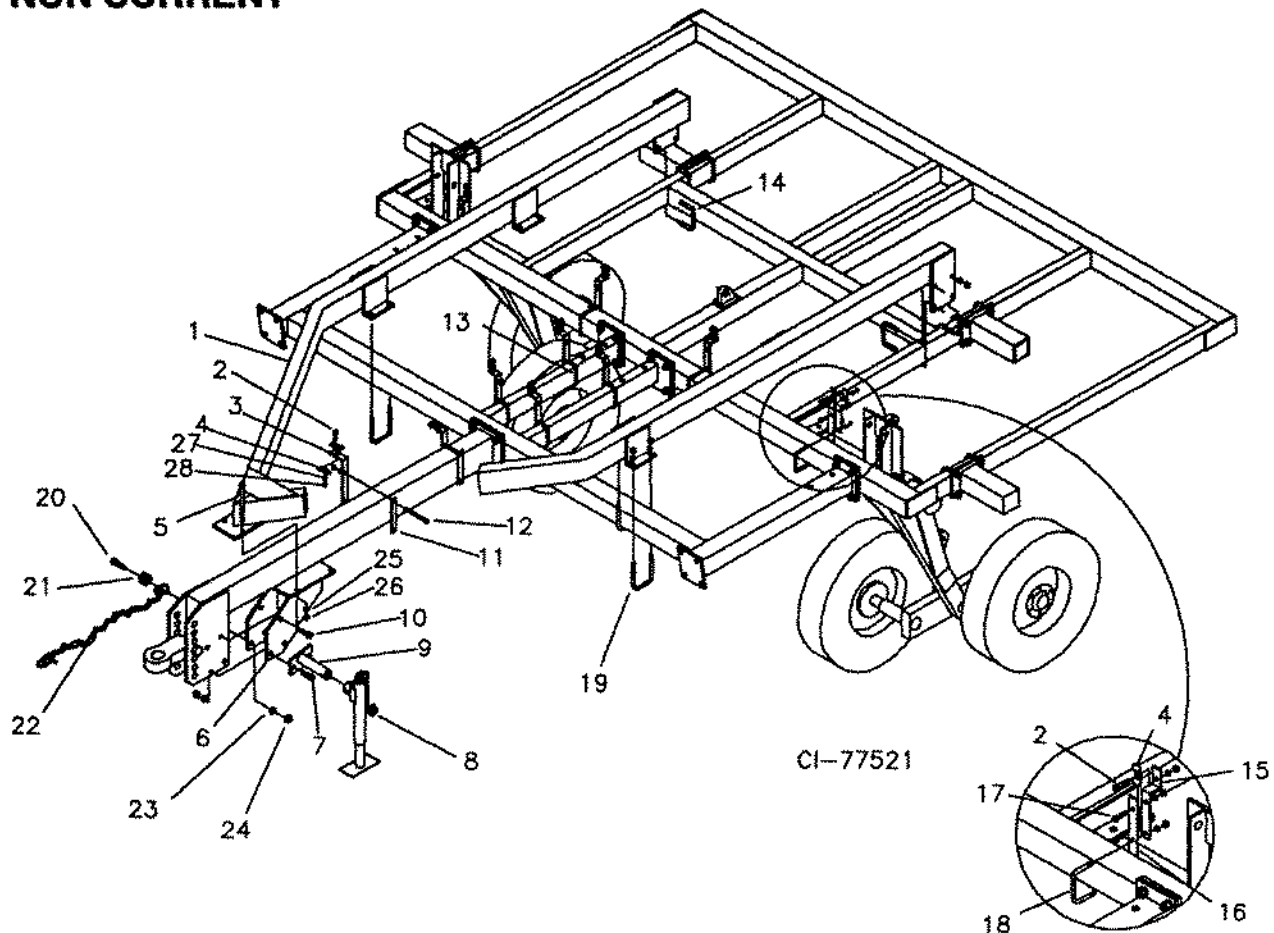

ITEM PART NO. DESCRIPTION

1	41181	4411 BRACE ASSEMBLY
2	88553	BOLT 3/8NC X 1-1/2
3	18213	TUBE SUPPORT
4	13215	TUBE CLAMP
5	88476	BOLT 5/8NC X 8 GR5
6	41190	HITCH BRACE
7	88404	BOLT 3/4NC X 2-1/2 GR5
8	12796	POLE JACK
9	41249	JACK MOUNT
10	88290	BOLT 3/4NC X 2 GR8
11	18212	STRAP
12	88583	BOLT 3/8NC X 5-1/2
13	88515	U-BOLT 3/8NC X 4 X 2-3/4
14	88388	U-BOLT 5/8NC X 4 X 3-1/4

ITEM PART NO. DESCRIPTION

15	13277	TUBE BRACKET
16	22995	STRAIGHT TUBE BRACKET
17	88157	BOLT 3/8NC X 1
18	88385	U-BOLT 3/8NC X 4 X 4-3/4
19	88145	U-BOLT 5/8NC X 4 X 5-1/4
20	88111	BOLT 3/4NC X 3-1/2 GR5
21	88131	FLAT WASHER 3/4
22	55174	SAFETY CHAIN
23	88130	LOCK WASHER 3/4
24	88110	NUT 3/4NC
25	88129	LOCK WASHER 5/8
26	88126	NUT 5/8NC
27	88362	LOCK WASHER 3/8
28	88103	NUT 3/8NC

9 & 9-11 SHANK MAIN FRAME

NON CURRENT

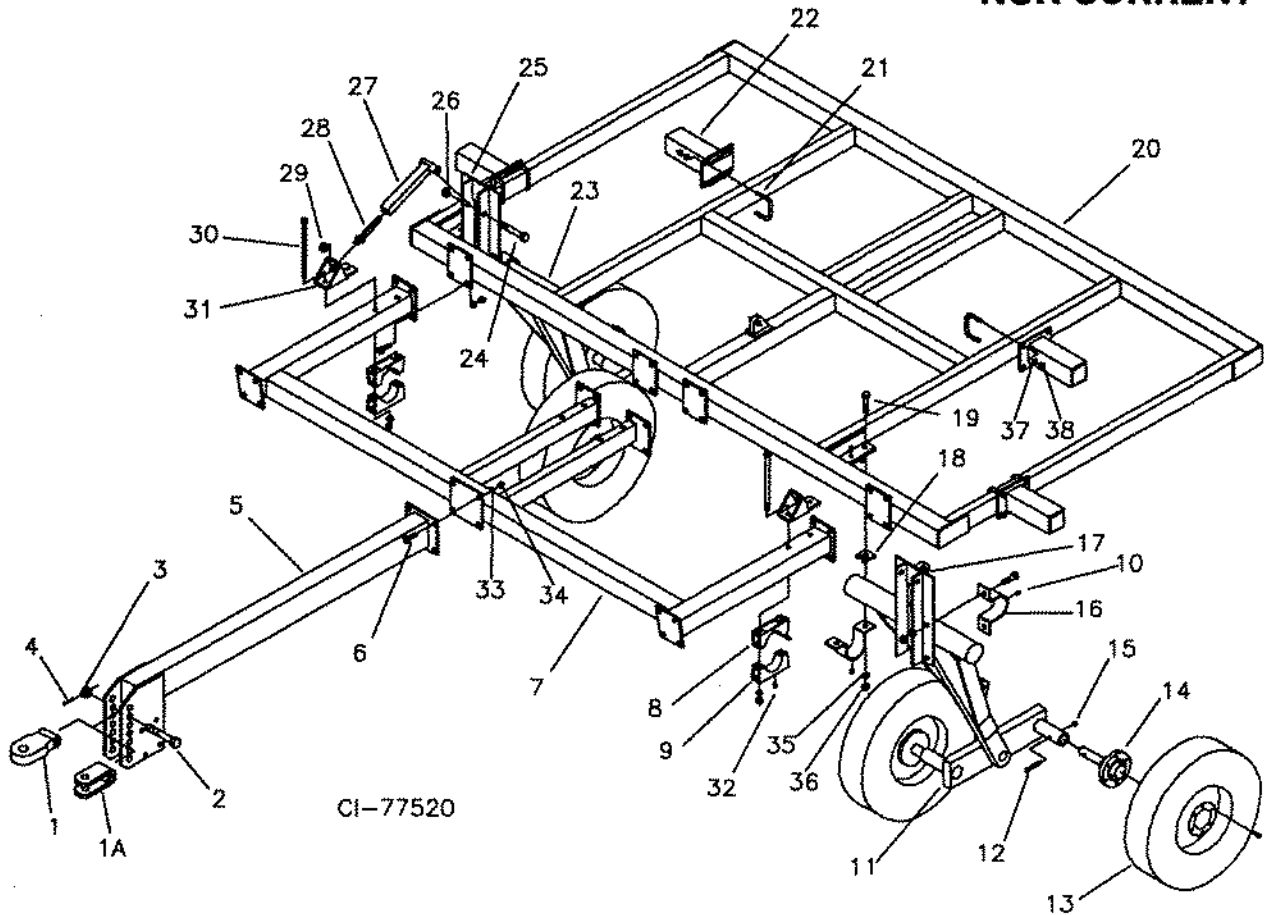

ITEM PARTNO. DESCRIPTION

1	18237	CAST HITCH
1A	11364	CLEVIS HITCH
2	11638	HITCH BOLT 1-1/4NC X 6-1/2 GR5
3	88350	SLOTTED NUT 1-1/4NC
4	88133	COTTER PIN 3/16 X 2
5	29769	4411 MAIN POLE
6	88290	BOLT 3/4NC X 2 GR8
7	29748	DISK MOUNT FRAME
8	34000	TOP AXLE CLAMP
9	33999	LOWER AXLE CLAMP
10	88263	GREASE FITTING 1/8NPT
11	29773	LEFT MAIN AXLE
12	88429	BOLT 1/2NF X 3-1/4 GR5
13	13142	9.5L X 15 TIRE ASSEMBLY
	10236	15 X 6 6-BOLT RIM
	11950	9.5L X 16 6-PLY TIRE
	11956	7.60/9.5L X 15 TUBE
14	14131	2IN HUB & SPINDLE
15	88304	LOCK NUT 1/2NF
16	10399	3IN AXLE CAP
17	29721	8.0 TBP AXLE MAST

ITEM PARTNO. DESCRIPTION

18	10176	AXLE SPACER
19	88495	BOLT 7/8NC X 2-1/2 GR5
20	29712	4411 MAIN FRAME (9-SHANK)
21	88388	U-BOLT 5/8NC X 4 X 3-1/4
22	29779	STUB
23	29774	RIGHT MAIN AXLE
24	88264	BOLT 1NC X 6 GR5
25	29724	9.3 TBP AXLE MAST
26	88348	LOCK NUT 1NC
27	29756	TORQUE BAR
28	48890	ADJUSTMENT ROD
29	88125	NUT 1NC
30	88871	BOLT 3/4NC X 12 GR5
31	29760	MAST REST
32	88550	GREASE FITTING 1/4NF
33	88130	LOCK WASHER 3/4
34	88110	NUT 3/4NC
35	88341	LOCK WASHER 7/8
36	88371	NUT 7/8NC
37	88129	LOCK WASHER 5/8
38	88126	NUT 5/8NC

4411 CUTTER CHISEL PARTS (74088) 12/94

9 & 9-11 CUTTER GANG

NON CURRENT

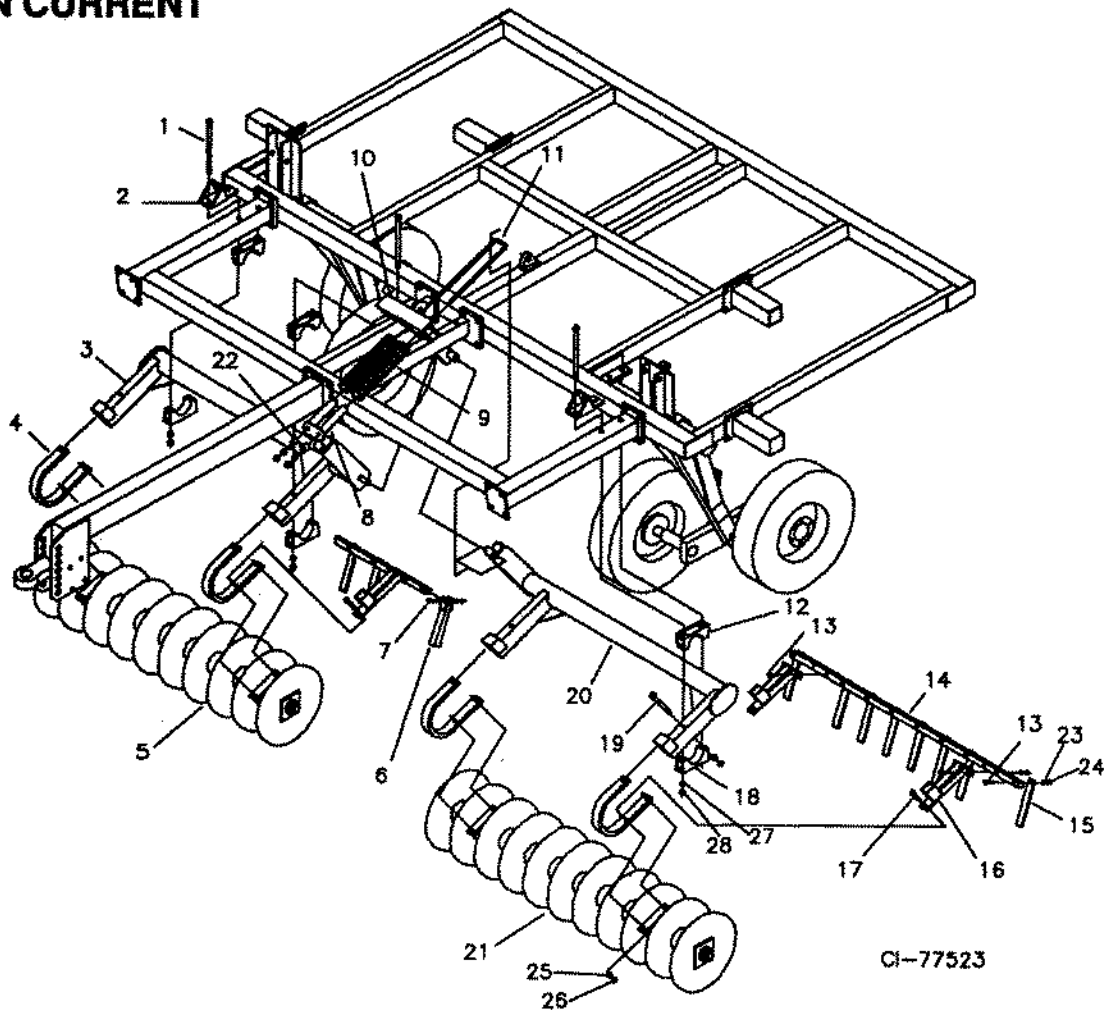

ITEM PART NO. DESCRIPTION

1	88871	BOLT 3/4NC X 12 GR5
2	29760	MAST REST
3	29735	RIGHT DISK AXLE
4	41250	SPRING SHANK
5	29782	9-BLADE GANG (9 SHANK MODEL)
	29781	10 BLADE GANG (11 SHANK MODEL)
6	29789	CENTER SCRAPER BAR
7	88541	BOLT 1/2NC X 3 GR5
8	22289	SPRING GUIDE
9	23340	COMPRESSION SPRING
10	29764	DISK LEVER
11	22287	U-BOLT 3/4NC X 2-1/2 X 21
12	34132	TOP AXLE CLAMP
13	88410	BOLT 1/2NC X 2-1/2 GR5
14	29775	63.5IN SCRAPER BAR (9 SHANK MODEL)
	40408	69.0IN SCRAPER BAR (11 SHANK MODEL)

ITEM PART NO. DESCRIPTION

15	29749	SCRAPER BAR
16	29750	SCRAPER BRACKET
17	88408	BOLT 5/8NC X 3 GR5
18	34131	LOWER AXLE CLAMP
19	88293	BOLT 3/4NC X 6 GR5
20	29734	LEFT DISK AXLE
21	29781	10-BLADE GANG (9 SHANK MODEL)
	40403	11-BLADE GANG (11 SHANK MODEL)
22	41371	SPRING BUSHING
23	88303	1/2 LOCK WASHER
24	88104	NUT 1/2NC
25	88129	LOCK WASHER 5/8
26	88126	NUT 5/8NC
27	88130	LOCK WASHER 3/4
28	88110	NUT 3/4NC