



ASSEMBLY/OPERATOR'S & PARTS MANUAL

4 BAR FORMED CHANNEL COIL TINE HARROW

WARRANTY

The only warranty Wil-Rich gives and the only warranty the dealer is authorized to give is as follows:

We warrant products sold by us to be in accordance with our published specifications or those specifications agreed to by us in writing at time of sale. Our obligation and liability under this warranty is expressly limited to repairing, or replacing, at our option, within 12 months after date of retail delivery, any product not meeting the specifications. ***We make no other warranty, express or implied and make no warranty of merchantability or of fitness for any particular purpose.*** Our obligation under the warranty shall not include any transportation charges or costs or installation or any liability for direct, indirect or consequential damage or delay. If requested by us, products or parts for which a warranty claim is made are to be returned transportation prepaid to our factory. Any improper use, operation beyond rated capacity, substitution of parts not approved by us, or any alteration or repair by others in such manner as in our judgment affects the product materially and adversely shall void this warranty. ***No employee or representative is authorized to change this warranty in any way or grant any other warranty.***

Wil-Rich reserves the right to make improvement changes on any of our products without notice.

When warranty limited or not applicable: Warranty on hoses, cylinders, hubs, spindles, engines, valves, pumps or other trade accessories are limited to the warranties made by the respective manufactures of these components. Rubber tires and tubes are warranted directly by the respective tire manufacturer only, and not by Wil-Rich.

Warranty does not apply to any machine or part which has been repaired or altered in any way so as in the our judgment to affect its reliability, or which has been subject to misuse, negligence or accident.

A Warranty Validation and Delivery Report Form must be filled out and received by Wil-Rich to initiate the warranty coverage.

WARRANTY CLAIMS PROCEDURE

1. The warranty form must be returned to Wil-Rich within fifteen (15) working days from the repair date.
2. Parts returned to Wil-Rich without authorization will be refused. The parts must be retained at the dealership for ninety (90) days after the claim has been filed. If the Service Department would like to inspect the parts, a packing slip will be mailed to the dealer. The packing slip must be returned with the parts. The parts must be returned prepaid within thirty (30) days of receiving authorization. After the parts are inspected and warranty is verified, credit for the return freight will be issued to the dealer.
3. Parts that will be scrapped at the dealership will be inspected by a Wil-Rich Sales Representative, District Sales Manager or Service Representative within the ninety (90) day retaining period.

TO THE OWNER

It is the responsibility of the user to read the Operator's Manual and comply with the safe and correct operating procedures as pertains to the operation, lubrication and maintenance of the product according to the information outlined in the Operator's Manual.

If this machine is used by an employee or is loaned or rented, make certain that the operator(s), prior to operating, is instructed in safe and proper use and reviews and understands the Operator's Manual.

The user is responsible for inspecting his/her machine and for having parts repaired or replaced when continued use of this product would cause damage or excessive wear to the other parts. The word NOTE is used to convey information that is out of context with the manual text; special information such as specifications, techniques, reference information of supplementary nature.

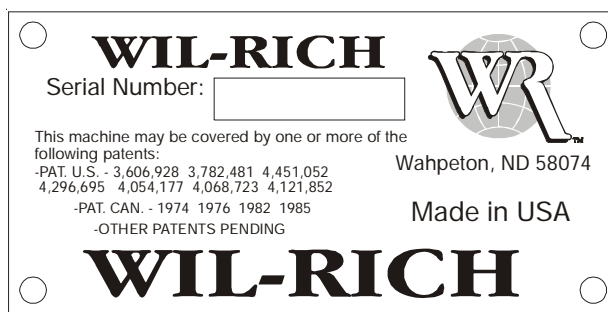

When in need of parts, always specify the model and serial number. Write this number in the space provided. The serial number plate is located on the main frame in the front left corner.

MODIFICATIONS

It is the policy of Wil-Rich to improve its products whenever possible and practical to do so. We reserve the right to make changes, improvements and modifications at any time without incurring obligation to make such changes, improvements on any equipment sold previously.

CONTENTS

MODIFICATIONS	3
TO THE OWNER	3
GENERAL INFORMATION	4
TO THE OPERATOR	5
SAFETY	5
PREPARATION	5
BEFORE OPERATING	5
DURING OPERATION	5
ON HIGHWAY OPERATION	5

ASSEMBLY

INSTALL MOUNTING ARMS	6
OPEN PACKAGING	6
INSTALL #1 SECTION BARS ACROSS THE MAINFRAME	6
INSTALL #1 SECTION BARS ACCROSS THE MAINFRAME	7
INSTALLATION OF MAINFRAME SECTION BARS #2-#4	8
INSTALLATION OF WING SECTION BARS #1-#4	9
INSTALLATION OF THE TINE ANGLE BRACKETS	10
7-1/2' FORMED CHANNEL HARROW	11
TINE ANGLE BRACKET	12
SECTION ASSEMBLY	12
4BAR COIL TINE CHANNEL HARROW EXTENSIONS	13
11' XL ² PLACEMENT CHART	14
13' XL ² /QX ² PLACEMENT CHART	15
16' XL ² /QX ² PLACEMENT CHART	16
13' XL ² /QX ² 5-SEC CHART	17
16' XL ² /QX ² 5-SEC CHART	18
DCIII PLACEMENT CHART	19

OPERATION

FIELD SETTINGS AND ADJUSTMENTS	20
INITIAL SHOP SETTINGS	20
FIELD ADJUSTMENT	21
SECTION OPERATING DEPTH ADJUSTMENT	21
SECTION LEVEL ADJUSTMENT	22
TINE ANGLE ADJUSTMENT	23-25

PARTS

4 BAR FORMED CHANNEL C/TINE SECTION	26
HARROW SECTION BAR	27
HARROW ARM ASSEMBLY	28
ANGLE TINE BRACKET	29
HARROW EXTENSIONS	30

GENERAL INFORMATION

Remove all wires and/or banding material. The parts have been conveniently arranged on the pallet for ease of assembly.

NOTE: Always wear safety glasses or goggles and be careful when cutting wires and steel bands as they are under tension and will spring back when cut.

Wherever the terms "left" and "right" are used, it must be understood to mean from a position behind and facing the machine.

Lubricate all bearings and moving parts as you proceed and make sure they work freely.

Loosely install all bolts connecting mating parts before final tightening.

When tightening bolts, they must be torqued to the proper number of foot-pounds as indicated in the table unless specified. It is important that all bolts be kept tight.

On new machines, all nuts and bolts must be re-checked after a few hours of operation.

When replacing a bolt, use only a bolt of the same grade or higher. Except in shear bolt applications, where you must use the same grade bolt.

Bolts with no markings are grade 2



Grade 5 bolts furnished with the machine are identified by three radial lines on the head.

Grade 8 bolts furnished with the machine are identified by six radial lines on the head.

All U-bolts are grade 5.



THIS SYMBOL USED TO CALL YOUR ATTENTION TO INSTRUCTIONS CONCERNING YOUR PERSONAL SAFETY. BE SURE TO OBSERVE AND FOLLOW THESE INSTRUCTIONS

	GRADE 2			GRADE 5			GRADE 8		
									
TORQUE IN FOOT POUNDS									
BOLT DIA	3/8	1/2	5/8	3/4	7/8	1			
HEX HEAD	9/16	3/4	15/16	1-1/8	1-5/16	1-1/2			
UNC GR2	18	45	89	160	252	320			
UNC GR5	30	68	140	240	360	544			
UNC GR8	40	100	196	340	528	792			
UNF GR2	21	51	102	178	272	368			
UNF GR5	32	70	168	264	392	572			
UNF GR8	48	112	216	368	792	840			

TORQUE.EPS

CAUTION

FAILURE TO FOLLOW THESE INSTRUCTIONS MAY RESULT IN PERSONAL INJURY AND/OR EQUIPMENT DAMAGE.

- Just before and during operation be sure no one is on or around the implement.
- Before activating the hydraulic system, check hoses for proper connections.
- Before lowering the wings for the first time, make sure the entire system has been charged with oil.
- With wings down always install hydraulic cylinder channel lock(s) for transporting.

49165

TO THE OPERATOR

SAFETY

Safety decals appear at various locations on your machine. The decals are provided for your safety and must be kept clean. Replace any decal that becomes worn, damaged, painted over or otherwise difficult to read. Replacement decals are available through you Wil-Rich dealer.



PREPARATION

Before using the Wil-Rich Harrow a careful inspection must become routine. A check must be made to insure that all hardware is securely tight and moving parts are able to move freely.

Tighten all loose nuts and bolts a replace any bent or broken parts.

BEFORE OPERATING

Use extreme care when making adjustments.

When working under or around Wil-Rich equipment always unfold wings and lower shanks to the ground **BEFORE SERVICING**.

After servicing, be sure all tools, parts, or service equipment is removed from the machine.

Make sure there is no one on or near the machine before or during operation.

DURING OPERATION

Reduce speed when cornering on field ends and when operating on or across dead furrows.

Do not attempt to remove any obstruction while the machine is in motion.

Use extreme care when operating close to ditches, fences or on hillsides.

No one other than operator should ride on the tractor.

Before and during operation be sure no one is on or around the implement. Serious injury can result from improper use.

ON HIGHWAY OPERATION

Comply with your local laws governing highway safety when moving machinery on a highway.

Reduce road speed on corners.

Drive at a responsible speed to maintain complete control of the machine at all times.

A S.M.V. emblem must be used at all times while traveling on public roads.

1.) OPEN PACKAGING

All the required parts for the complete mounting of the harrow sections to the unit should be contained in two to three pallets. The parts are packaged on the pallet in a manner to allow removal and assembly to the unit in a specific sequence.

Do not remove parts from the pallet until the assembly instructions direct you to do so.

Locate the cardboard box that is contained on one of the pallets. This box contains the assembly, mounting and operating instruction and any required mounting hardware. Open this box and remove the Assembly/Operators manual and associated papers.

Refer to the Assembly/Operators manual for the assembly and mounting instructions.

In the paper work is a Harrow Mounting Chart for your cultivator. Remove the chart and keep it in a central location.

2.)INSTALL MOUNTING ARMS

Locate your particular unit size on the left side of the chart and refer to the arm location mounting dimensions for your model.

Mark the rear centerline of the unit. The noted dimensions are measured left and right from this centerline point. Mark the mounting arm locations on the rear bar.

Remove the assembled mounting arms from the pallet and loosely attach the arms to the rear frame bar with the U-bolts and hardware provided in the hardware kits.

Tighten U-bolts to hold the arms in position but still allow the arms to be moved laterally.

Do not fully tighten the mounting hardware at this time.

For assembly hardware reference see Fig 6A, page11.

3.) INSTALL #1 SECTION BARS ACROSS THE MAIN FRAME

The harrow section bars are contained on a single pallet, packaged with the larger section bars on the bottom of the pallet.

Locate a #1 section bar for each section used on your particular main frame.

Placement of the #1 section bar is critical to the placement of the remaining section bars and to the functioning of the harrow.

Exact Section Bar Lengths:

4-1/2ft Section	=	45"
6ft Section	=	63"
7-1/2ft Section	=	81"

The mounting chart gives the sections required for each model. The sections are arranged as they are to be mounted. Arrange the main frame section bars under the mounting arms.

The section bars are spaced 9" from each other. The main frame section bar width is **centered on the main frame.**

Determine the section bar overhang. See the SAMPLE on fig 2.

Attach the section bars to the mounting arm pivot brackets.

See fig 2.

Note: It may be necessary to move the mounting arms laterally to get section bar to mount to the pivot brackets. It may also require the removal of the bolts that attach the coil tine clamp to the section bar if the pivot bracket must be located in that position.

3.) INSTALL #1 SECTION BARS ACROSS THE MAIN FRAME

EXAMPLE - FIND SECTION BAR WIDTH	
6FT SECTION	63"
SPACE	9"
6FT SECTION	63"
SPACE	9"
6FT SECTION	63"
TOTAL	207"

EXAMPLE FIGURING OVERHANG	
SECTION BAR WIDTH	207"
MAIN FRAME WIDTH	<u>192"</u>
TOTAL OVERHANG	15"
DIVIDED BY 2	7-1/2"
OVERHANG EACH SIDE	7-1/2"

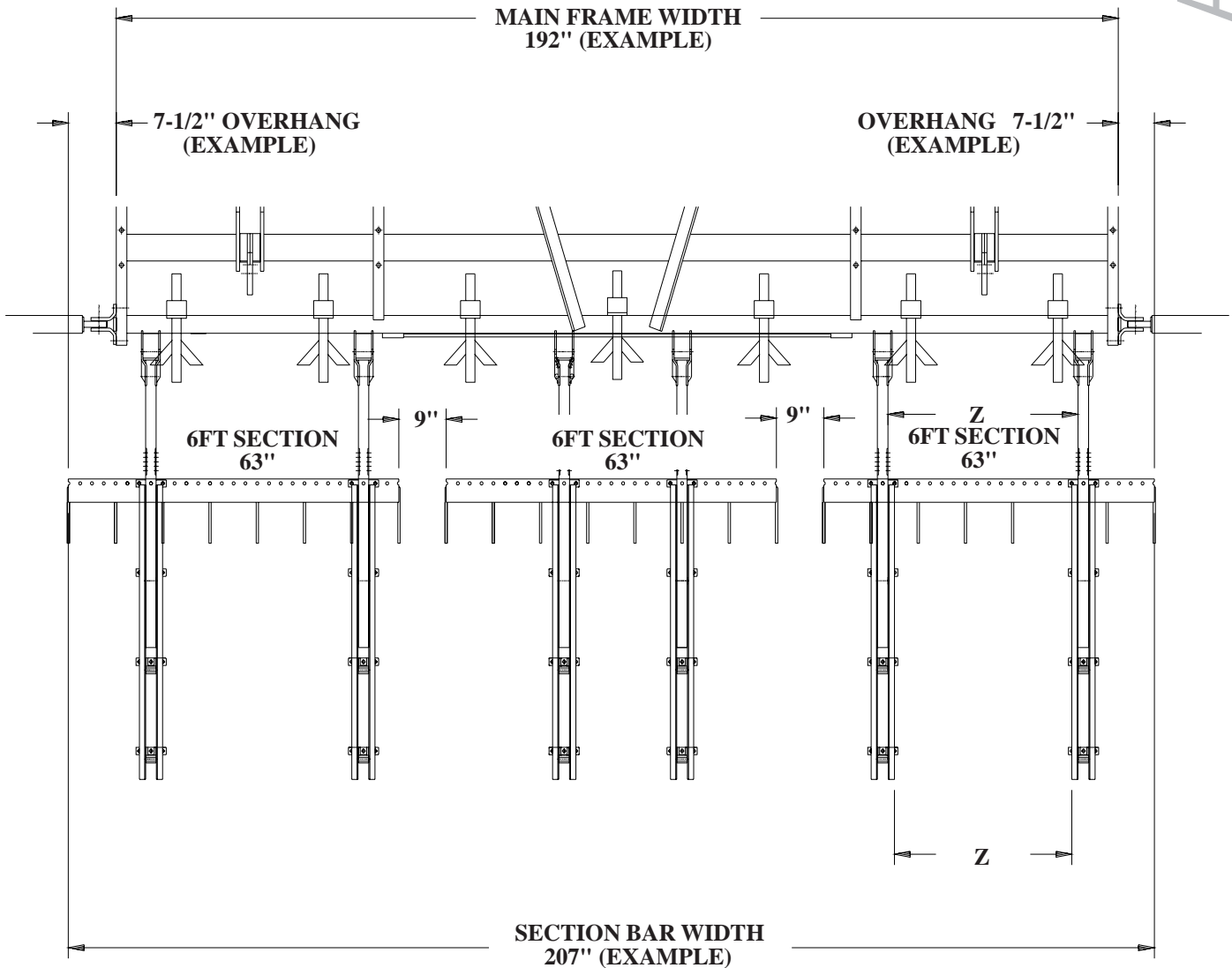

Fig. 2

Once the No. 1 section bars are in position, measure the distance (Z) between the mounting arms as shown in Fig. 2. front and back to ensure that the arms are parallel. If they are not, move the arms on the rear bar of the cultivator to position them correctly while maintaining the section location relative to the unit centerline.

4.)INSTALLATION OF MAIN FRAME SECTION BARS #2 - #4

Once the mounting arms and #1 section bars have been loosely positioned, attach the remaining section bars to complete the section. Refer to Fig. 3 for the correct position of the #2, #3 and #4 section bars relative to the #1 section bar.

Note: The remaining section bars must be placed as shown on all sections to ensure proper function of the harrows.

Recheck the location and offset of the section bars, as these sections are the basis for locating and mounting the remaining sections.

Once positioning is validated, tighten all mounting hardware.

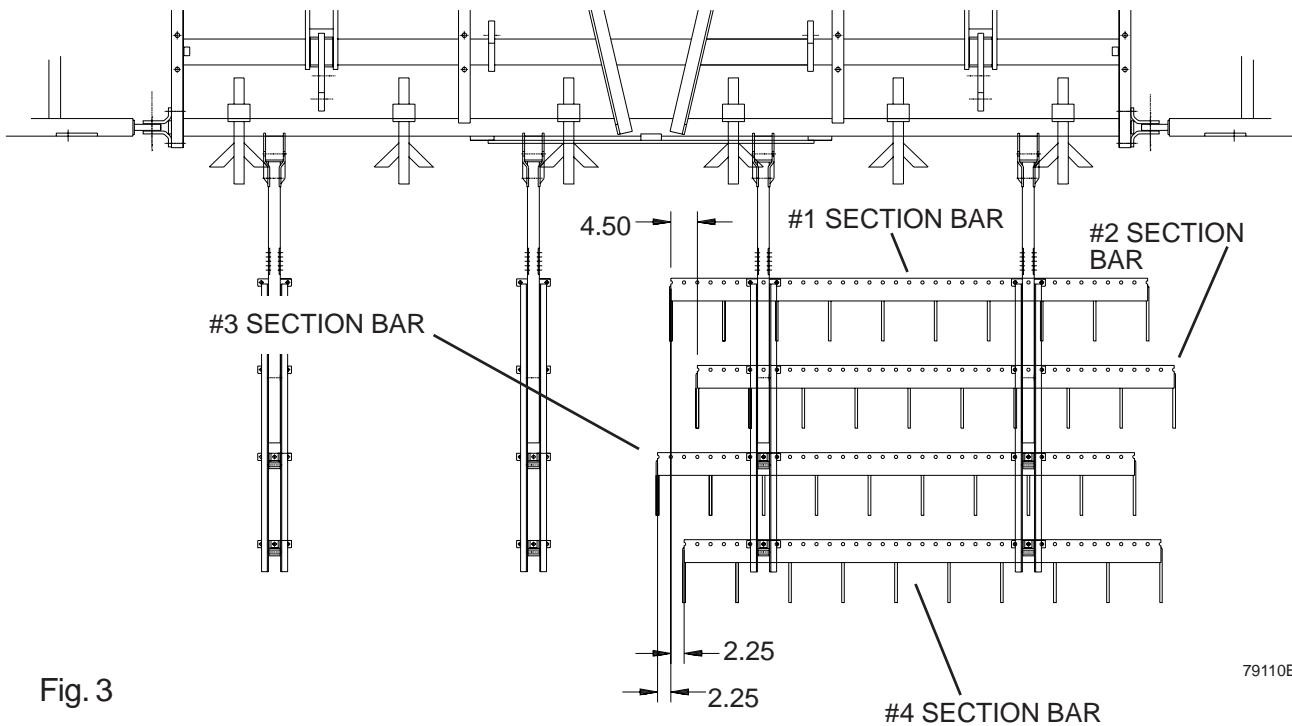

Fig. 3

79110E

Locate a section bar of the correct length required for the remaining harrow sections. Using the 9" dimensions shown on Fig 4, position and mount the #1 section bar on all the remaining arms of the unit.

Check that the mounting arms are parallel and adjust as required.

5.)INSTALLATION OF WING SECTION BARS #1 - #4

Check the general placement of the #1 bar to determine any obvious interference with the mounting arms or section bars. If everything looks functional you can mount section bars #2, #3 and #4 on the remaining sections.

Once all section bars and mounting arms are correctly positioned the mounting hardware can be tightened to the noted torque ratings.

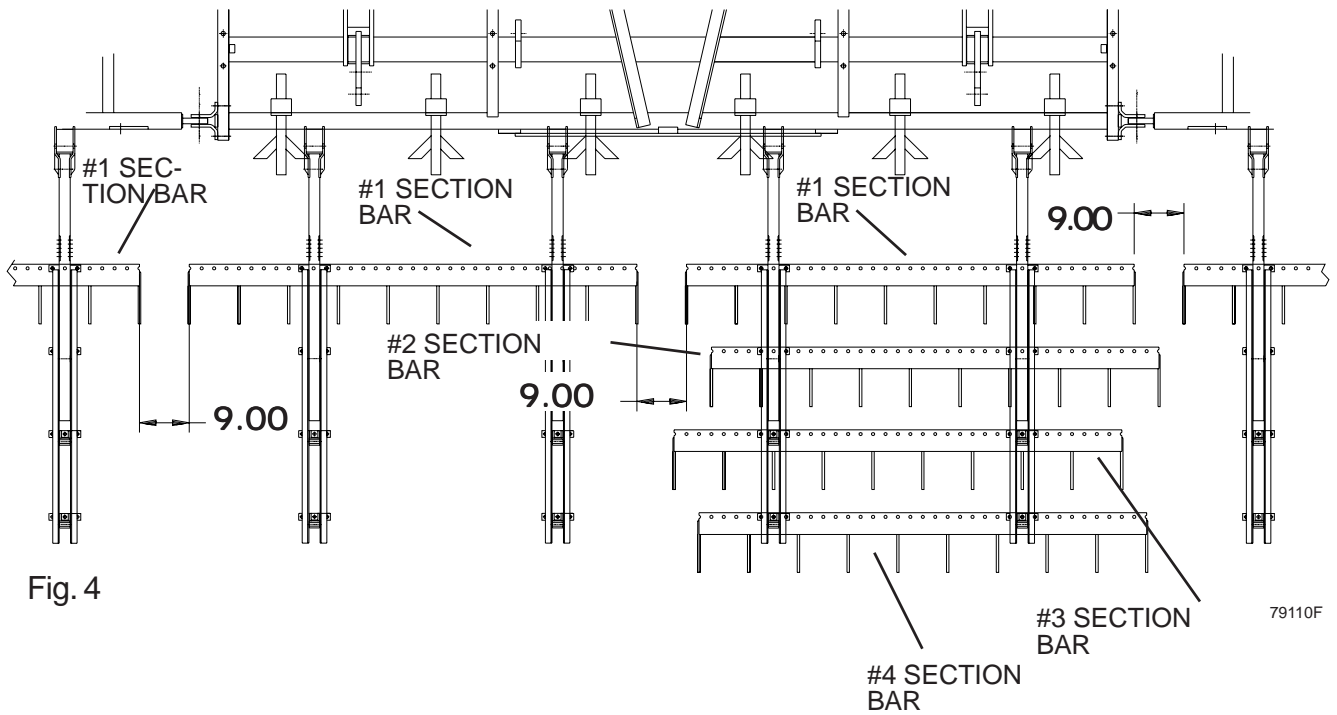

Fig. 4

79110F

6.) INSTALLATION OF THE TINE ANGLE BRACKETS

Position a tine angle bracket on the front and rear section bar as shown in Fig. 5. Center the tine angle bracket in the center of the section and secure with hardware noted. Make certain the tine angle brackets are parallel to the mounting arms (Dim X. Fig. 5).

Insert the spacer (67188) into the pivot bracket and position the tine angle bracket as shown into the top adjustment holes. Secure with the pin and hairpin cotter as shown in Fig. 6.

Once all hardware is secured, fold the wings of the unit and check for any mounting bracket interference or other contact between parts.

It may be necessary to re-position a mount arm by moving the tine angle brackets on the section bars laterally. Make certain to tighten all hardware if parts are repositioned.

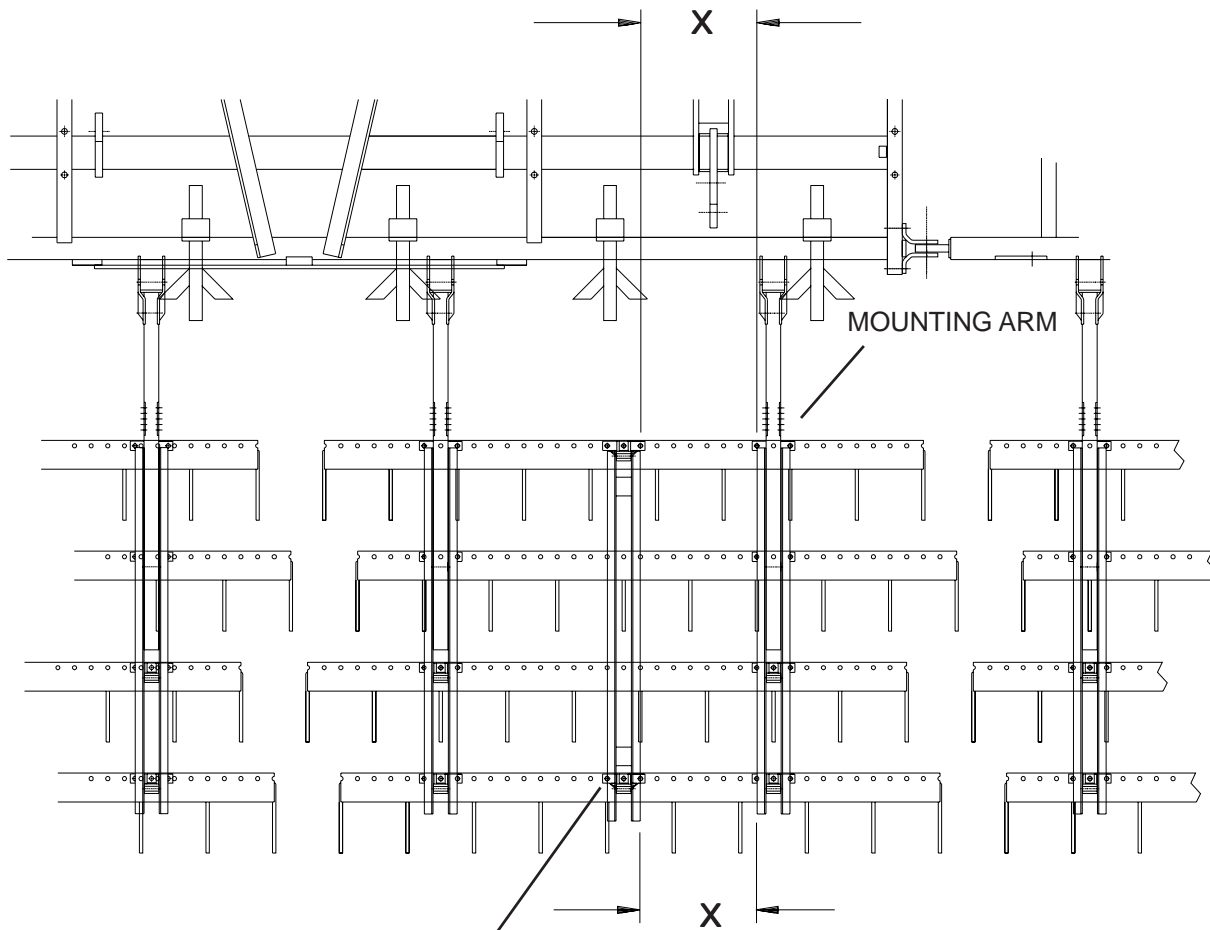

Fig. 5

79110G

TINE ANGLE BRACKET
 NOTE: 7-1/2 FT SECTIONS REQUIRE (2)
 BRACKETS SEE PAGE 11 FOR PLACE-
 MENT

7-1/2' FORMED CHANNEL HARROW

ASSEMBLY

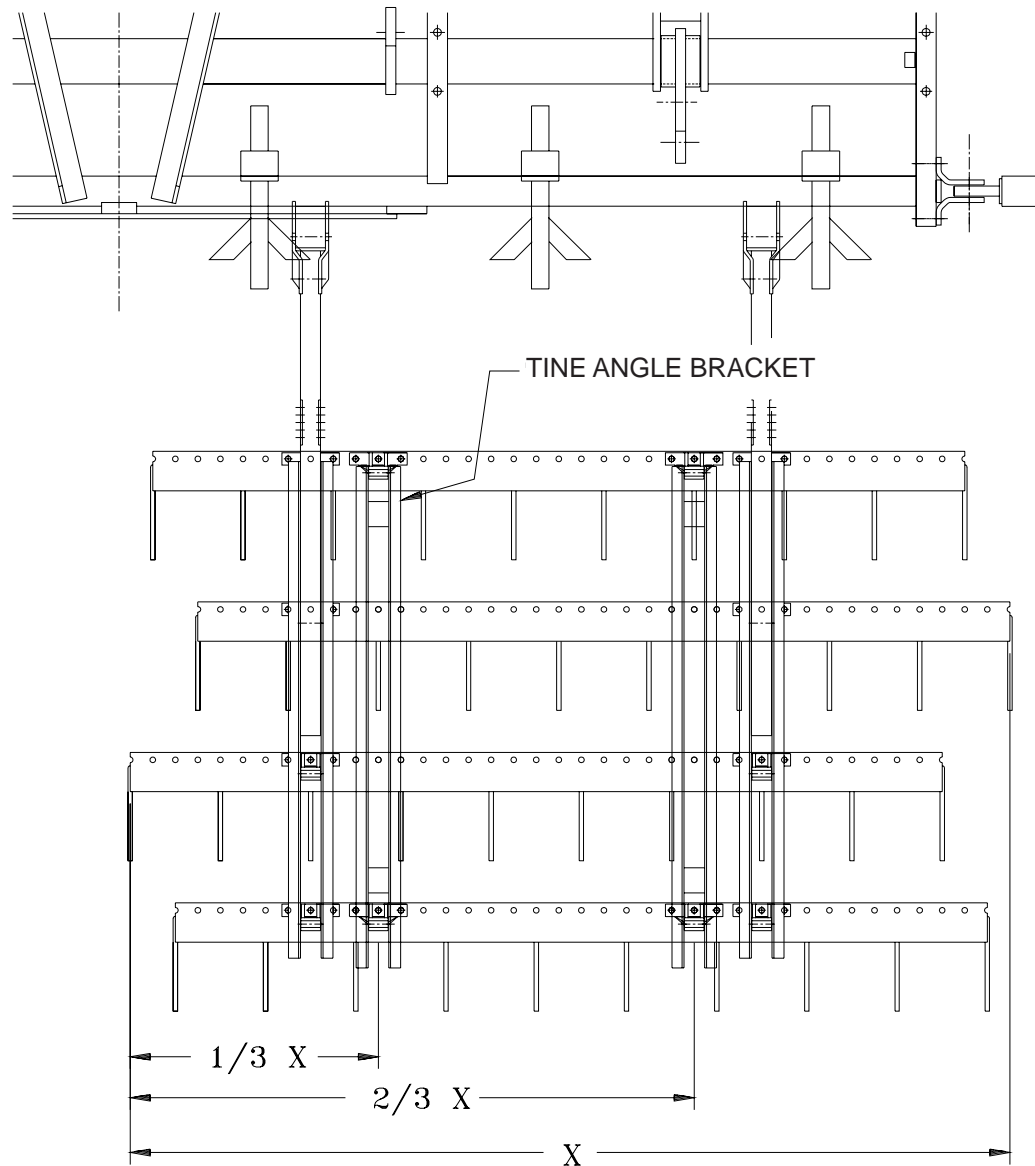

ON 7-1/2' HARROW SECTIONS, 2 TINE ANGLE BRACKETS ARE UTILIZED. LOCATE THESE BRACKETS APPROXIMATELY EQUAL ACROSS THE WIDTH OF THE SECTION AS SHOWN ABOVE. SECURE THE TINE ANGLE BRACKETS PER THE ASSEMBLY INSTRUCTIONS.

TINE ANGLE BRACKET

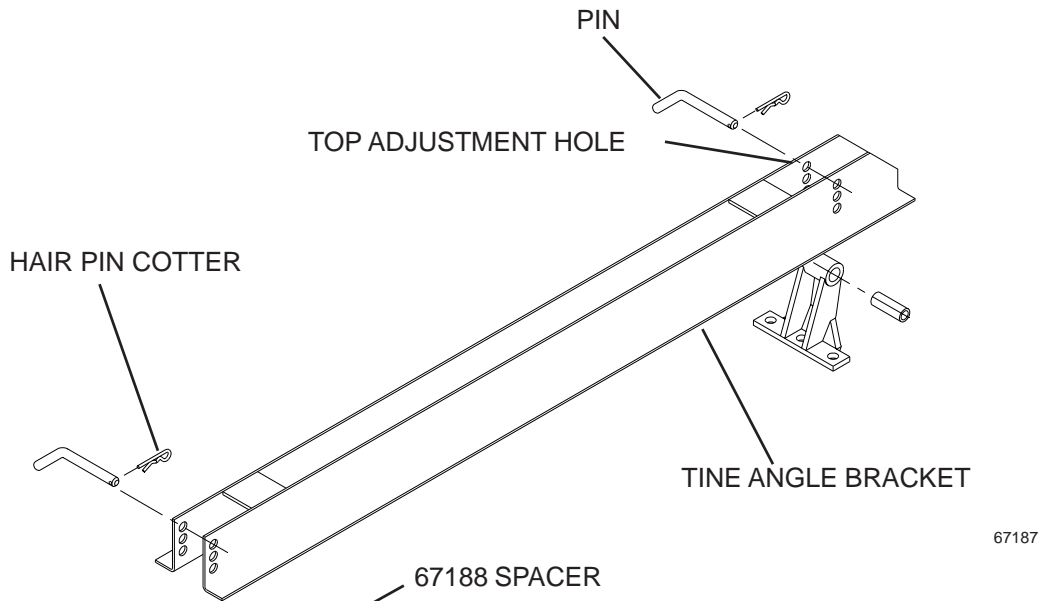

Fig. 6

SECTION ASSEMBLY

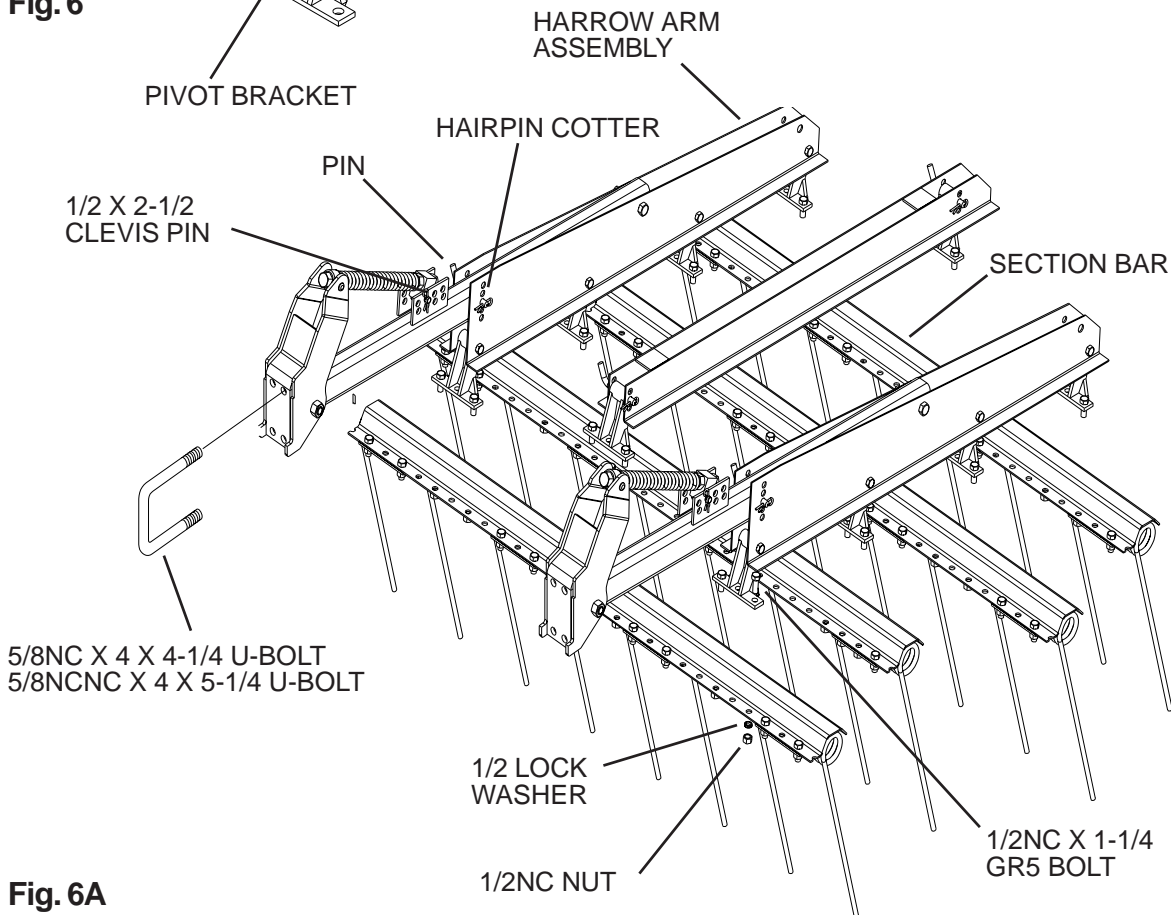
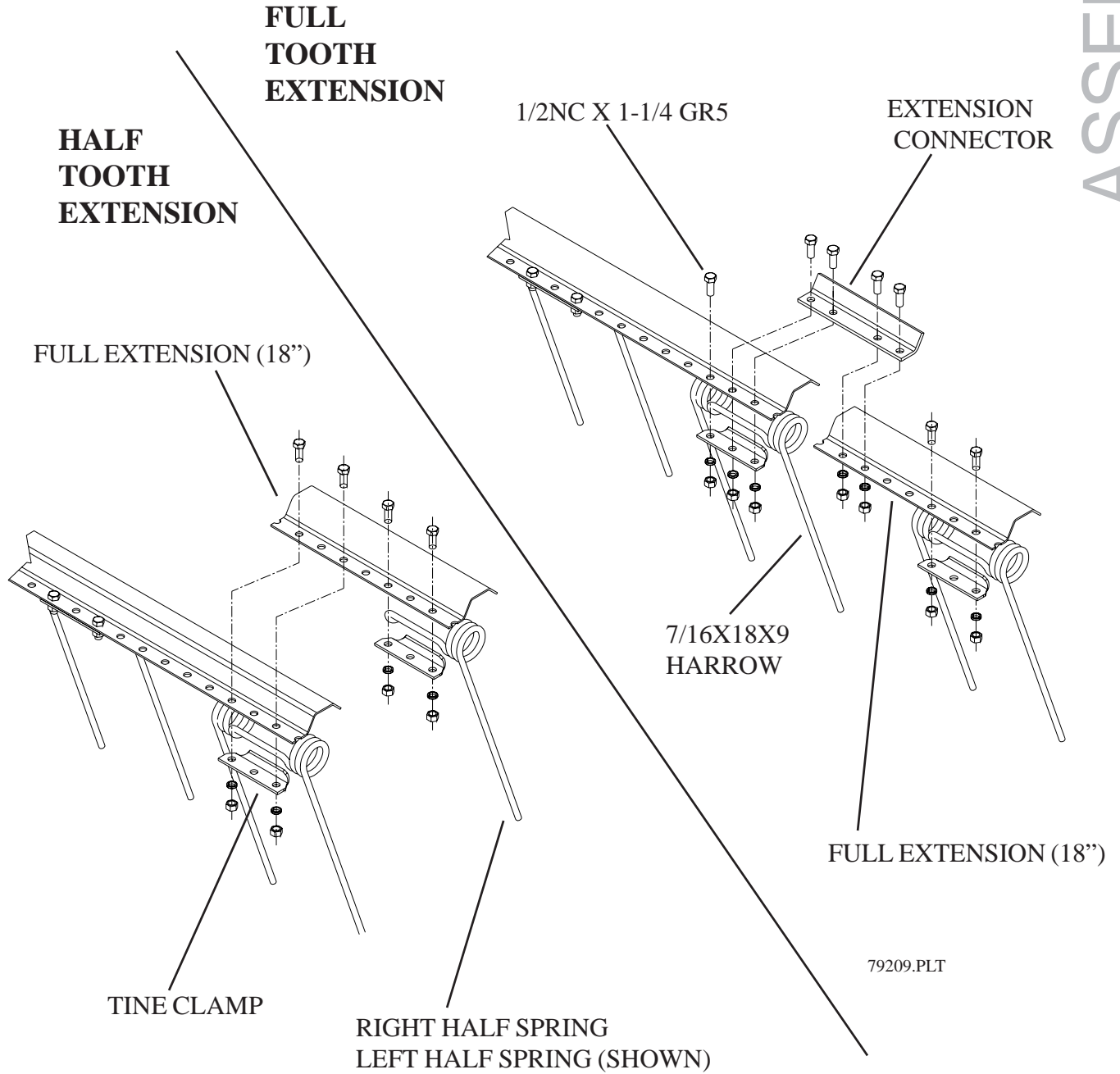

Fig. 6A

4-BAR COIL TINE CHANNEL HARROW EXTENSIONS

ASSEMBLY



11' MF XL² CULTIVATOR 4-BAR COIL TINE HARROW

NOTE: EXACT ARM LOCATION COULD VARY EITHER DIRECTION, DEPENDENT ON IMPLEMENT ACCESSORIES. DO NOT TIGHTEN ARMS COMPLETELY UNTIL ALL SECTIONS ARE IN PLACE.

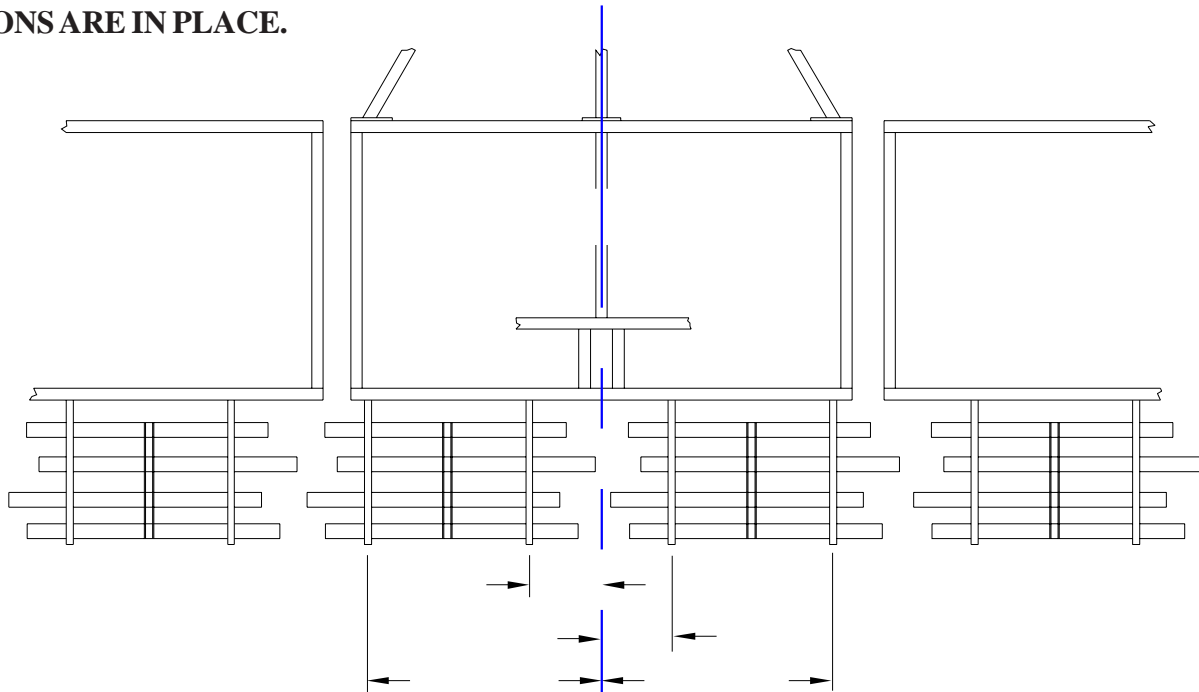

56	36	0	56	- ARM LOCATION (INCH FROM CENTER LINE) - SECTION
4-1/2'		7-1/2'		

	WING'S				MAIN FRAME				WING'S							
11 XL 19-20	113	89			60	35	4	55			89	113				
	4-1/2'				4-1/2'		7-1/2'				4-1/2'					
11 XL 19-22	119	98			62	10	32	62			98	119				
	4-1/2'				7-1/2'		6'				4-1/2'					
11 XL 25	144	90			52	21	22	52			94	146				
	7-1/2'				6'		6'				7-1/2'					
11 XL 25 - 26	148	98			62	10	32	62			98	148				
	7-1/2'				7-1/2'		6'				7-1/2'					
11 XL 25 - 27	148	98			62	18	18	62			98	148				
	7-1/2'				7-1/2'		7-1/2"				7-1/2'					
11 XL 25 - 30	176	156	122	96	62	14	22	62	94	120	146	174				
	4-1/2'		4-1/2'		7-1/2'		6'		4-1/2'		4-1/2'					
11 XL 30	174	152	124	98	62	14	22	62	94	120	146	172				
	4-1/2'		4-1/2'		7-1/2'		6'		4-1/2'		4-1/2'					
11 XL 30 - 31	174	144	106	90	58	18	14	54	90	108	140	174				
	6'		4-1/2'		6'		6'		4-1/2'		6'					
11 XL 30 - 32	184	152	122	98	62	12	24	64	94	118	152	184				
	4-1/2'		6'		7-1/2'		6'		6'		4-1/2'					
11 XL 30 - 34	202	160	128	92	50	14	14	50	92	128	160	202				
	6'		6'		6'		6'		6'		6'					
11 XL 30 - 36	210	188	150	98	62	12	24	62	102	154	186	208				
	4-1/2'		7-1/2'		7-1/2'		6'		7-1/2'		4-1/2'					
11 XL 30 - 39	228	188	150	98	62	12	24	62	102	154	188	228				
	6'		7-1/2'		7-1/2'		6'		7-1/2'		6'					
11 XL 30 - 40	230	196	160	146	106	76	50	14	14	50	92	106	146	160	202	230
	6'		4-1/2'		4-1/2'		6'		6'		4-1/2'		4-1/2'		6'	

13' MF XL²/QX² CULTIVATOR 4 BAR COIL TINE HARROW

NOTE: EXACT ARM LOCATION COULD VARY EITHER DIRECTION, DEPENDENT ON IMPLEMENT ACCESSORIES. DO NOT TIGHTEN ARMS COMPLETELY UNTIL ALL SECTIONS ARE IN PLACE.

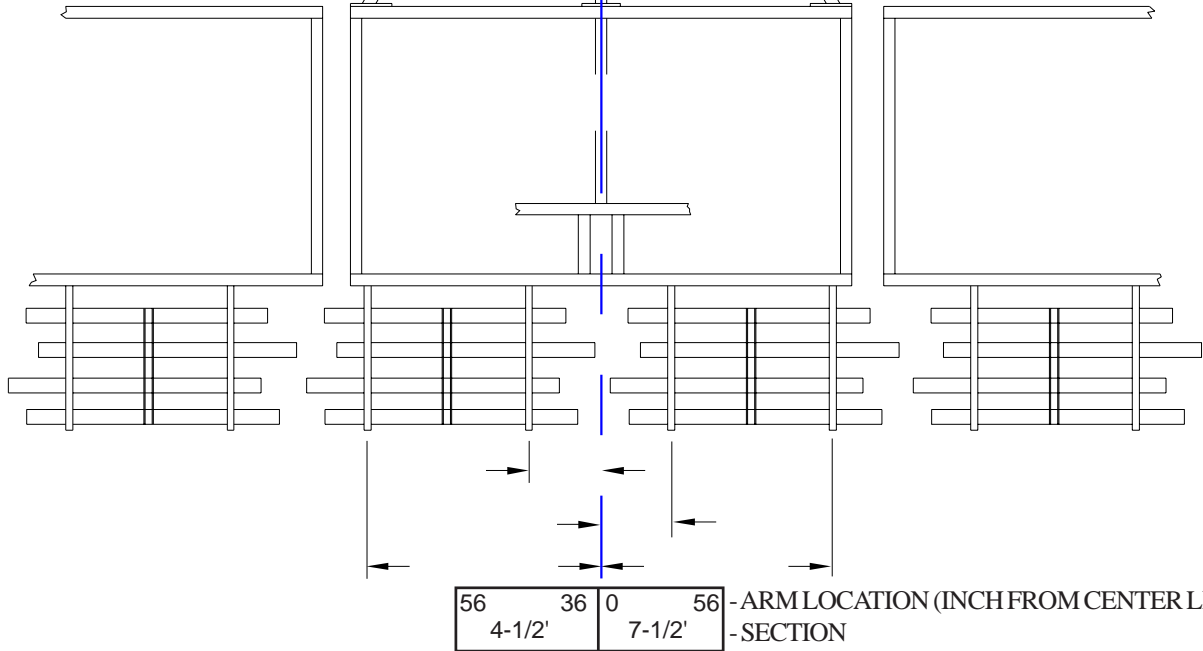

	WING'S				MAIN FRAME				WING'S							
13 XL/QX 32	189	169	141	110	70	13	20	70	110	141	169	189				
	4-1/2'		6'		7-1/2'		6'		6'		4-1/2'					
13 XL/QX 32-34	189	169	140	110	70	20	20	70	110	141	169	189				
	4-1/2'		6'		7-1/2'		7-1/2'		6'		4-1/2'					
13 XL/QX 32-37	218	176	148	110	70	20	20	70	110	148	176	218				
	6'		6'		7-1/2'		7-1/2'		6'		6'					
13 XL/QX 32-42	244	214	186	160	130	110	70	20	20	70	110	130	160	186	214	244
	6'		4-1/2'		4-1/2'		7-1/2'		7-1/2'		4-1/2'		4-1/2'		6'	
13 XL/QX 32-45	268	232	186	160	130	106	70	13	20	70	110	130	160	186	232	268
	7-1/2'		4-1/2'		4-1/2'		7-1/2'		6'		4-1/2'		4-1/2'		7-1/2'	
13 XL/QX 37	218	176	148	110	70	20	20	70	110	148	176	218				
	6'		6'		7-1/2'		7-1/2'		6'		6'					
13 XL/QX 37-39	215	188	151	111	63	14	27	65	111	151	188	215				
	6'		7-1/2'		7-1/2'		6'		7-1/2'		6'					
13 XL/QX 37-42	250	230	200	160	130	110	70	20	20	70	110	130	160	200	230	250
	4-1/2'		6'		4-1/2'		7-1/2'		7-1/2'		4-1/2'		6'		4-1/2'	
13 XL/QX 37-47	268	238	200	186	150	110	70	13	20	70	110	150	186	200	238	268
	6'		4-1/2'		7-1/2'		7-1/2'		6'		7-1/2'		4-1/2'		6'	
13 XL/QX 37-50	288	250	200	178	140	110	70	20	20	70	110	140	178	200	250	288
	6'		6'		6'		7-1/2'		7-1/2'		6'		6'		6'	

16' MF XL²/QX²CULTIVATOR 4-BAR COIL TINE HARROW

NOTE: EXACT ARM LOCATION COULD VARY EITHER DIRECTION, DEPENDENT ON IMPLEMENT ACCESSORIES. DO NOT TIGHTEN ARMS COMPLETELY UNTIL ALL SECTIONS ARE IN PLACE.

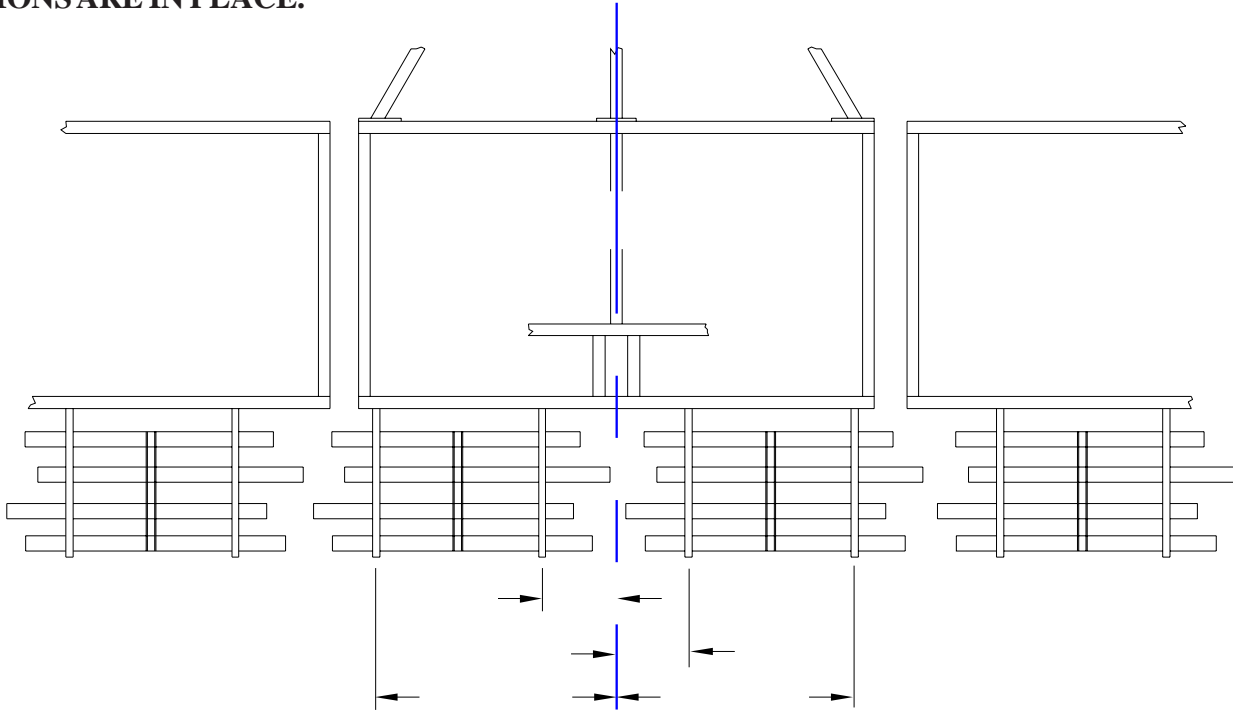

56	36	0	56	- ARM LOCATION (INCH FROM CENTER LINE)
4-1/2'		7-1/2'		

WING'S				MAIN FRAME				WING'S										
16EXC/QX 39	226 6'	188 6'	154 6'	116 6'	80 6'	48 4-1/2'	10 6'	10 4-1/2'	48 6'	80 6'	116 6'	154 6'	188 6'	226 6'				
16EXC/QX 39-40	230 6'	202 6'	164 6'	124 6'	92 6'	50 6'	20 6'	20 6'	50 6'	92 6'	124 6'	164 6'	202 6'	230 6'				
16EXC/QX 39-41	196 6'	174 6'	144 7-1/2'	104 6'	80 6'	48 4-1/2'	14 4-1/2'	14 4-1/2'	48 6'	80 6'	104 7-1/2'	144 6'	174 6'	196 6'				
16EXC/QX 39-45	266 4-1/2'	242 4-1/2'	212 4-1/2'	190 6'	154 6'	120 6'	80 6'	42 4-1/2'	14 4-1/2'	14 4-1/2'	42 6'	80 6'	120 6'	154 4-1/2'	190 4-1/2'	212 4-1/2'	242 6'	266 4-1/2'
16EXC/QX 39-46	266 4-1/2'	246 4-1/2'	222 4-1/2'	196 4-1/2'	164 6'	124 6'	92 6'	50 6'	20 6'	20 6'	50 6'	92 6'	124 6'	164 4-1/2'	196 4-1/2'	222 4-1/2'	246 4-1/2'	266 6'
16EXC/QX 39-48	286 4-1/2'	268 6'	230 6'	202 6'	154 6'	120 6'	80 6'	42 4-1/2'	14 4-1/2'	14 4-1/2'	42 6'	80 6'	120 6'	154 6'	202 6'	230 4-1/2'	268 4-1/2'	286 6'
16EXC/QX 39-50	284 6'	264 4-1/2'	217 4-1/2'	201 6'	163 6'	124 6'	88 6'	52 6'	21 6'	21 6'	52 6'	88 6'	124 6'	163 4-1/2'	201 6'	217 6'	264 6'	284 6'
16EXC/QX 39-52	284 7-1/2'	264 4-1/2'	217 4-1/2'	201 6'	163 6'	124 6'	88 6'	52 6'	21 6'	21 6'	52 6'	88 6'	124 6'	163 4-1/2'	201 6'	217 4-1/2'	264 6'	284 7-1/2'

13' MF 5 SECTION XL²/QX² CULTIVATOR 4-BAR COIL TINE HARROW

NOTE: EXACT ARM LOCATION COULD VARY EITHER DIRECTION, DEPENDENT ON IMPLEMENT ACCESSORIES. DO NOT TIGHTEN ARMS COMPLETELY UNTIL ALL SECTIONS ARE IN PLACE.

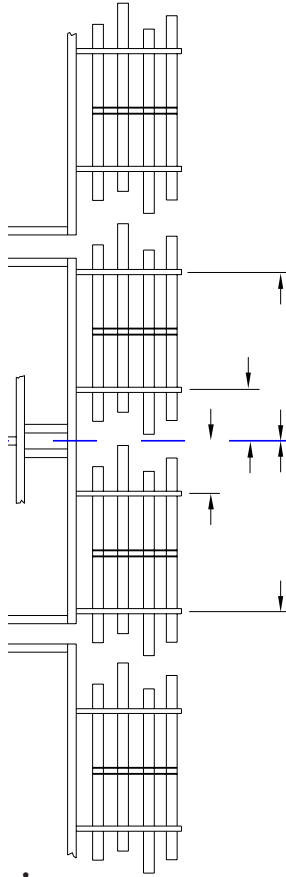

56	36	0	56
4-1/2'	7-1/2'	7-1/2'	- ARM LOCATION (INCH FROM CENTER LINE) - SECTION

	OUTER WINGS	INNER WINGS	MAIN FRAME	INNER WINGS	INNER WINGS	OUTER WINGS
13 5SECT 46	287 241 7-1/2'	217 177 145 110 4-1/2' 4-1/2'	75 20 26 26 7-1/2' 6'	70 70	110 145 177 217 4-1/2' 4-1/2'	241 287 7-1/2'
13 5SECT 46-48	287 241 7-1/2'	217 177 145 110 6' 4-1/2'	75 20 26 26 7-1/2' 6'	70 70	110 145 177 217 4-1/2' 6'	241 287 7-1/2'
13 5SECT 46-50	291 241 7-1/2'	217 177 145 110 6' 4-1/2'	75 20 26 26 7-1/2' 7-1/2'	70 70	110 145 177 217 4-1/2' 6'	241 291 7-1/2'
13 5SECT 50	298 244 7-1/2'	206 177 131 110 6' 6'	65 25 20 20 6' 7-1/2'	65 65	110 131 177 206 6' 6'	244 298 7-1/2'
13 5SECT 50-53	312 264 7-1/2'	217 177 131 110 7-1/2' 6'	65 25 20 20 6' 7-1/2'	65 65	110 131 177 217 6' 7-1/2'	264 312 7-1/2'
13 5SECT 55	327 301 271 253 4-1/2' 4-1/2'	217 177 145 110 6' 6'	75 49 20 20 49 75 4-1/2' 6' 4-1/2'	75 75	110 145 177 217 6' 6'	253 271 301 327 4-1/2' 4-1/2'
13 5SECT 55-58	342 315 287 241 4-1/2' 6'	217 177 145 110 6' 6'	75 49 20 20 49 70 4-1/2' 6' 4-1/2'	70 70	110 145 177 217 6' 6'	241 287 315 342 6' 4-1/2'
13 5SECT 55-60	346 315 287 241 6' 6'	217 177 145 110 6' 6'	75 20 26 26 7-1/2' 6'	70 70	110 145 177 217 6' 6'	241 287 315 346 6' 6'

16' MF 5 SECTION XL²/QX² CULTIVATOR 4-BAAR COIL TINE HARROW

NOTE: EXACT ARM LOCATION COULD VARY EITHER DIRECTION, DEPENDENT ON IMPLEMENT ACCESSORIES. DO NOT TIGHTEN ARMS COMPLETELY UNTIL ALL SECTIONS ARE IN PLACE.

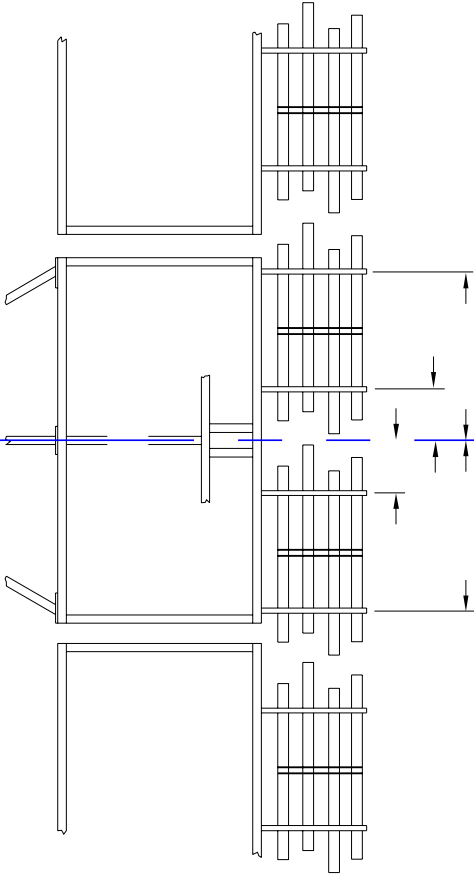

56	36	0	56
4-1/2'	7-1/2'	7-1/2'	-ARM LOCATION (INCH FROM CENTER LINE) -SECTION

	OUTER WINGS		INNER WINGS		MAIN FRAME		INNER WINGS		OUTER WINGS													
16 5SECT 53	313	268	228	201	163	134	91	62	20	20	62	91	134	163	201	228	268	313				
	7-1/2'	7-1/2'	4-1/2'	6'	6'	6'	6'	7-1/2'	6'	6'	6'	6'	6'	4-1/2'	6'	4-1/2'	7-1/2'	7-1/2'				
16 5SECT 53-54	325	274	228	201	154	125	91	50	21	21	50	91	125	154	201	228	274	325				
	7-1/2'	7-1/2'	6'	6'	6'	6'	6'	6'	6'	6'	6'	6'	6'	6'	6'	6'	7-1/2'	7-1/2'				
16 5SECT 53-55	325	274	228	201	154	125	91	50	21	21	50	91	125	154	201	228	274	325				
	7-1/2'	7-1/2'	6'	6'	6'	6'	6'	6'	6'	6'	6'	6'	6'	6'	6'	6'	7-1/2'	7-1/2'				
16 5SECT 58	342	303	275	248	217	177	150	125	91	50	21	21	50	91	125	150	177	217	248	275	303	342
	6'	6'	4-1/2'	6'	6'	6'	4-1/2'	6'	6'	6'	6'	6'	6'	6'	4-1/2'	6'	4-1/2'	6'	6'	4-1/2'	6'	6'
16 5SECT 58-59	352	314	284	259	230	190	159	131	91	62	20	20	62	91	131	159	190	230	259	284	314	352
	6'	6'	4-1/2'	6'	6'	6'	4-1/2'	6'	6'	7-1/2'	6'	6'	6'	6'	4-1/2'	6'	4-1/2'	6'	4-1/2'	6'	4-1/2'	6'
16 5SECT 58-60	352	314	284	259	230	190	159	131	91	62	20	20	62	91	131	159	190	230	259	284	314	352
	6'	6'	4-1/2'	6'	6'	6'	4-1/2'	6'	6'	7-1/2'	6'	6'	6'	6'	4-1/2'	6'	4-1/2'	6'	4-1/2'	6'	4-1/2'	6'

DCIII DISK CULTIVATOR 4-BAR COIL TINE HARROW ARM MOUNING LOCATIONS

42	22	27	60
4-1/2'		7-1/2'	

LEFT WING MAIN FRAME RIGHT WING

	LEFT WING	MAIN FRAME	RIGHT WING
11 DC III 19	108 79 6'	43 22 22 43 4-1/2'	79 108 6'
11 DC III 19-22	108 79 7-1/2'	43 22 22 43 4-1/2'	79 108 7-1/2'
11 DC III 25	144 108 6'	61 27 27 61 7-1/2'	108 144 6'
11 DC III 25-28	148 98 7-1/2'	62 10 32 62 7-1/2'	98 148 7-1/2'
11 DC III 31	180 158 131 95 4-1/2'	59 27 27 59 6'	95 131 158 180 6'
14 DC III 34	194 157 121 103 6'	57 22 22 57 7-1/2'	103 121 157 194 4-1/2'
14 DC III 34-37	209 157 121 103 7-1/2'	57 22 22 57 7-1/2'	103 121 157 209 4-1/2'

FIELD SETTINGS AND ADJUSTMENTS

Initial setting of the harrows can be completed before the unit is taken to the field. It must be noted that all final adjustments need to be made under field conditions with the tillage unit and harrow sections operating at the desired depth.

The WIL-RICH 4 Bar Formed Channel Coil Tine Harrow has a number of adjustments to set the sections to the required operating depth and tine angle. These adjustments include section operating depth, section operating level and tine angle adjustments.

Initial Shop Settings

Once all the sections have been mounted as noted in the Assembly Instructions move the tillage unit to a flat surface.

Unfold all sections and lower the tillage unit down so the sweeps are touching the ground.

Remove the level control pin that controls the level of the complete gang "A".

Remove the clevis pin "B" that adjusts the section depth as shown in Fig. 7.

With the tine angle bracket set in the top position reinsert the clevis pin "B" in the hole required to hold the section with the coil tines resting on the ground. Utilizing the level control pin "A" secure the section in this level position.

OPERATION

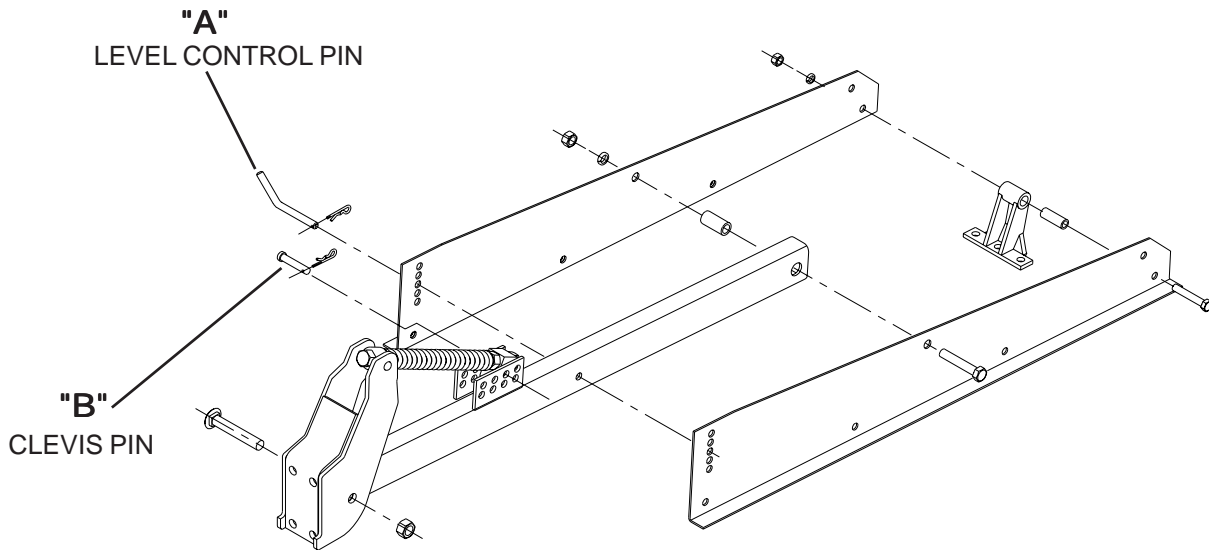

68201

FIG. 7.

FIELD ADJUSTMENT

Move to the field and set the main tillage unit to function at the depth desired. Check the front to rear and side to side level as noted in the Operators manual for the tillage unit.

Once the tillage unit has been properly set the harrows can be adjusted for proper function. Move the unit through the field and observe the function of the harrow. Adjust the following items as required.

SECTION OPERATING DEPTH ADJUSTMENT

There are 10 positions available to set the depth of the complete section as shown in Fig. 8.

By assembling the pin in the various positions the working depth is changed. By changing the pin position at this point you can also adjust the relative down pressure on the section. Adjust the position and down pressure as required, keeping in mind that by adjusting the section down you will also decrease the transport clearance of the harrow and change the level of the section.

This harrow has sufficient weight to function with limited spring down pressure in most situations.

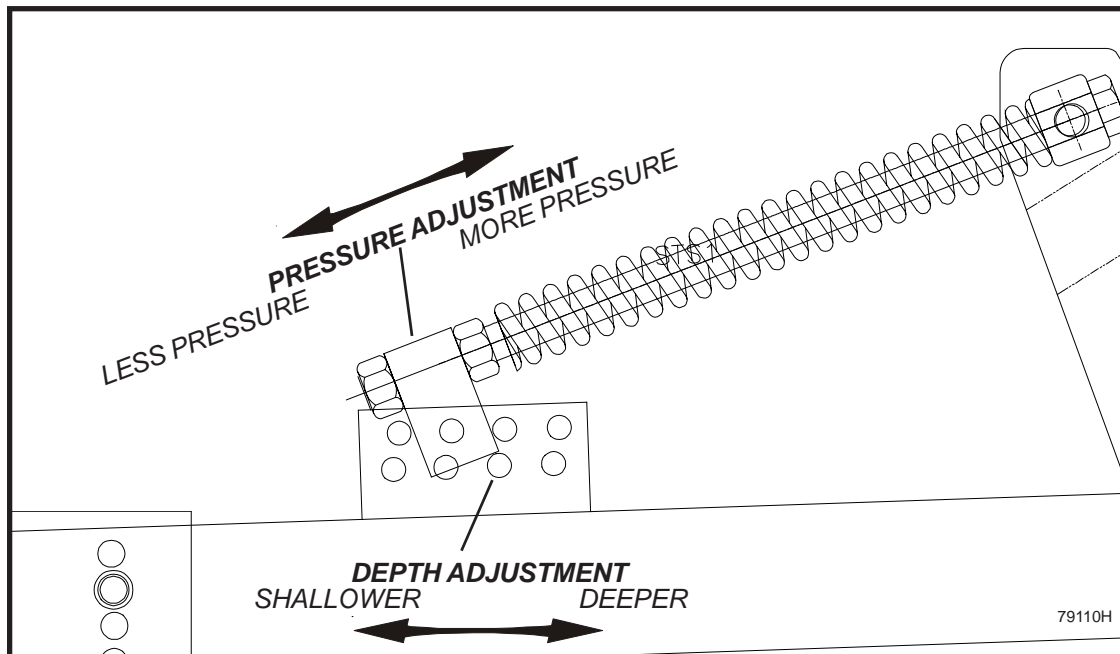

FIG. 8.

OPERATION

SECTION LEVEL ADJUSTMENT

To set the front to rear level of the section adjust the pin location as shown in Fig. 9. Remove the pin and rotate the section as required. The section should be set to run level in the working position. As a general rule the front of the section will be carried somewhat higher when in the transport position as the section arms pivot up when the section is in the operating position.

To rotate the section into the storage position remove the pin and rotate the section forward over the top of the carrying arms as shown in Fig 10. Replace pin to hold the section in the desired position. With changes in operating conditions additional adjustment may be required.

Note: When harrow is in storage position, make certain harrow sections do not contact or interfere at wing hinge points when folding the wings.

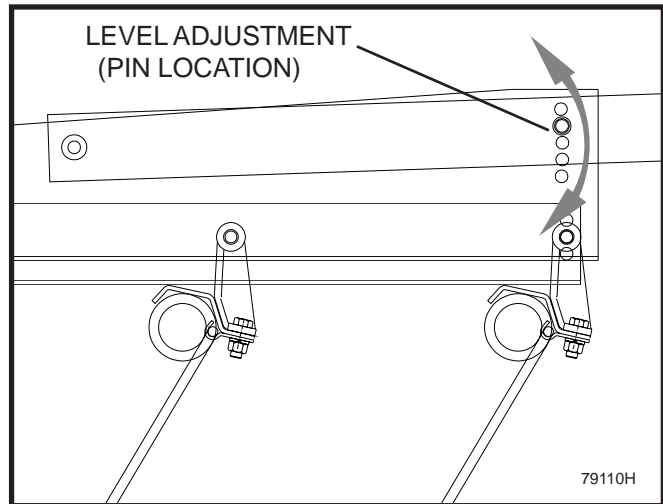

Fig. 9.

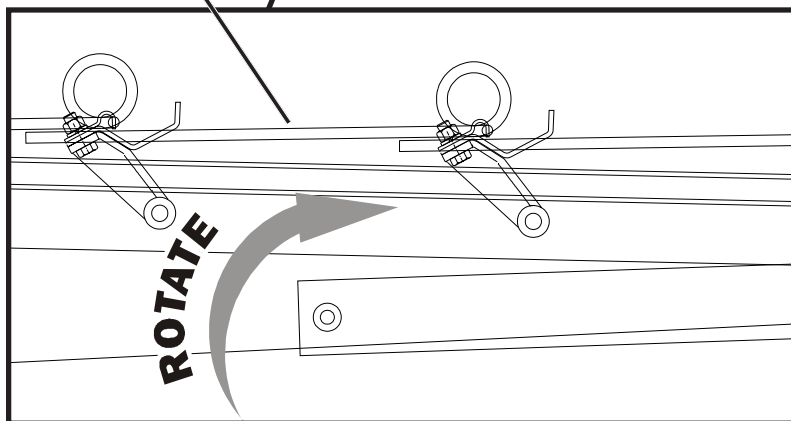
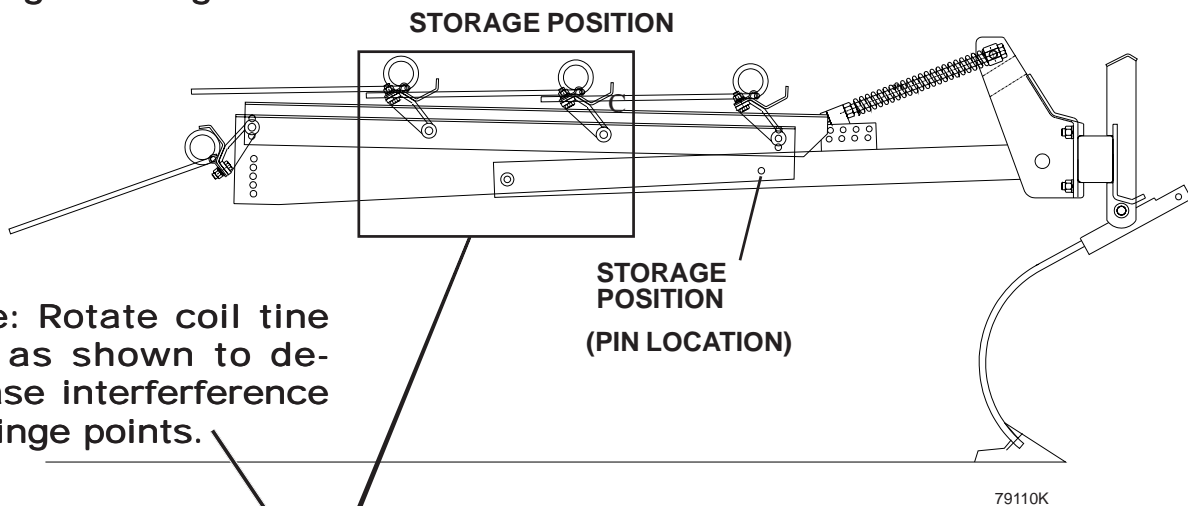
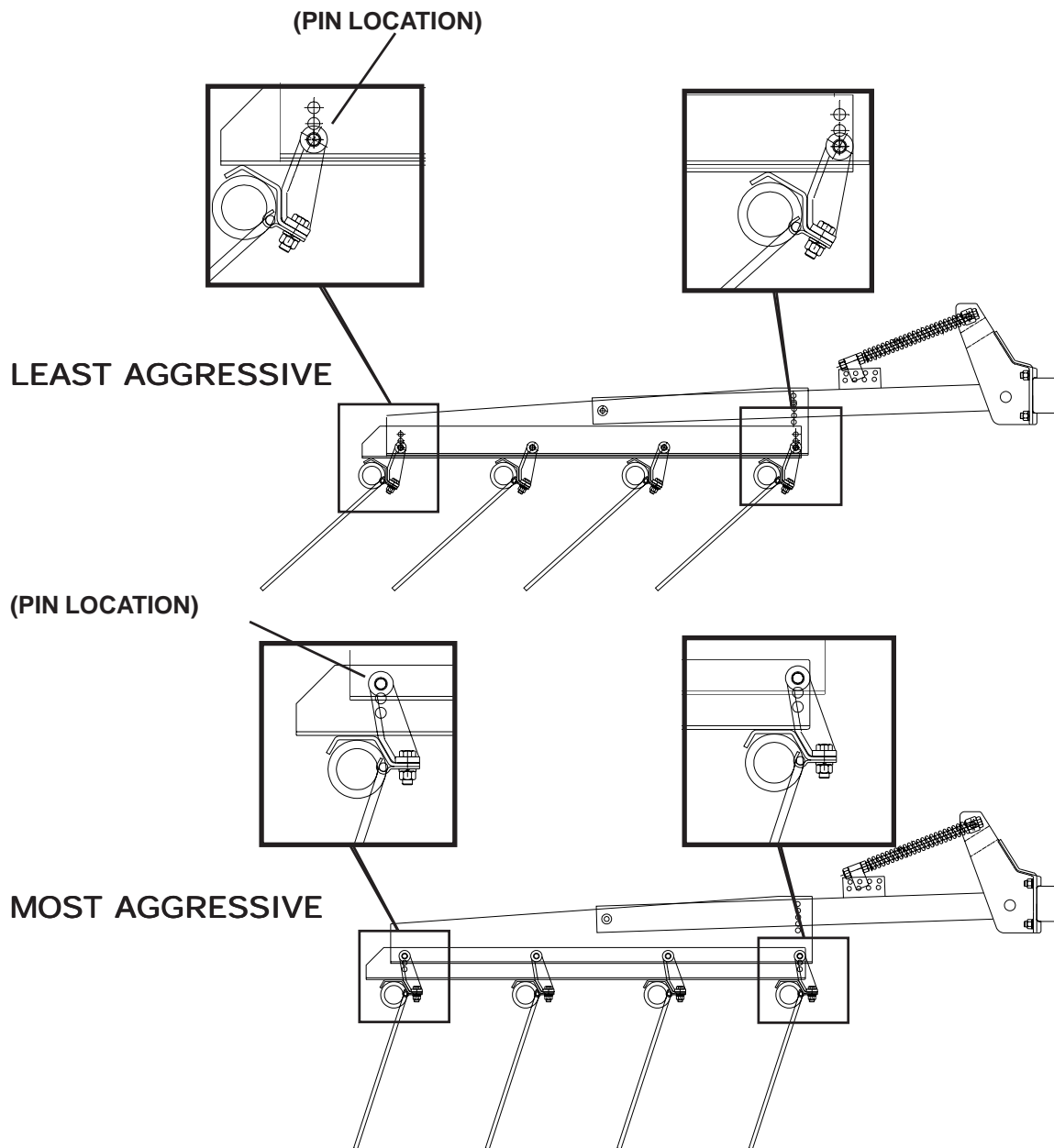

Fig. 10.

TINE ANGLE ADJUSTMENT

Adjusting the tine angle bracket to any of the three positions shown in Fig.11. controls the working angle of the tine. Pinning the tine angle bracket in the lower hole allows the section bars to rotate back to the least aggressive position. This position will allow trash to move more easily through the harrow with reduced soil mixing.

Pinning in the upper holes will set the tine angle to its most aggressive position. Setting the harrow at the aggressive setting will allow the harrow to move more soil and knock down ridges but will be less tolerant of trash.



79110L

Fig. 11.

The tine angle of the section bars can be varied from the front to rear bar.

By placing the tine angle bracket assembly in the upper hole on the front bar and in the lower hole on the rear bar you can vary the section bar tine angles as shown in Fig.12.

This tine angle setting will give a more aggressive working action at the front of the section and a less aggressive, trash shedding action at the rear of the harrow.

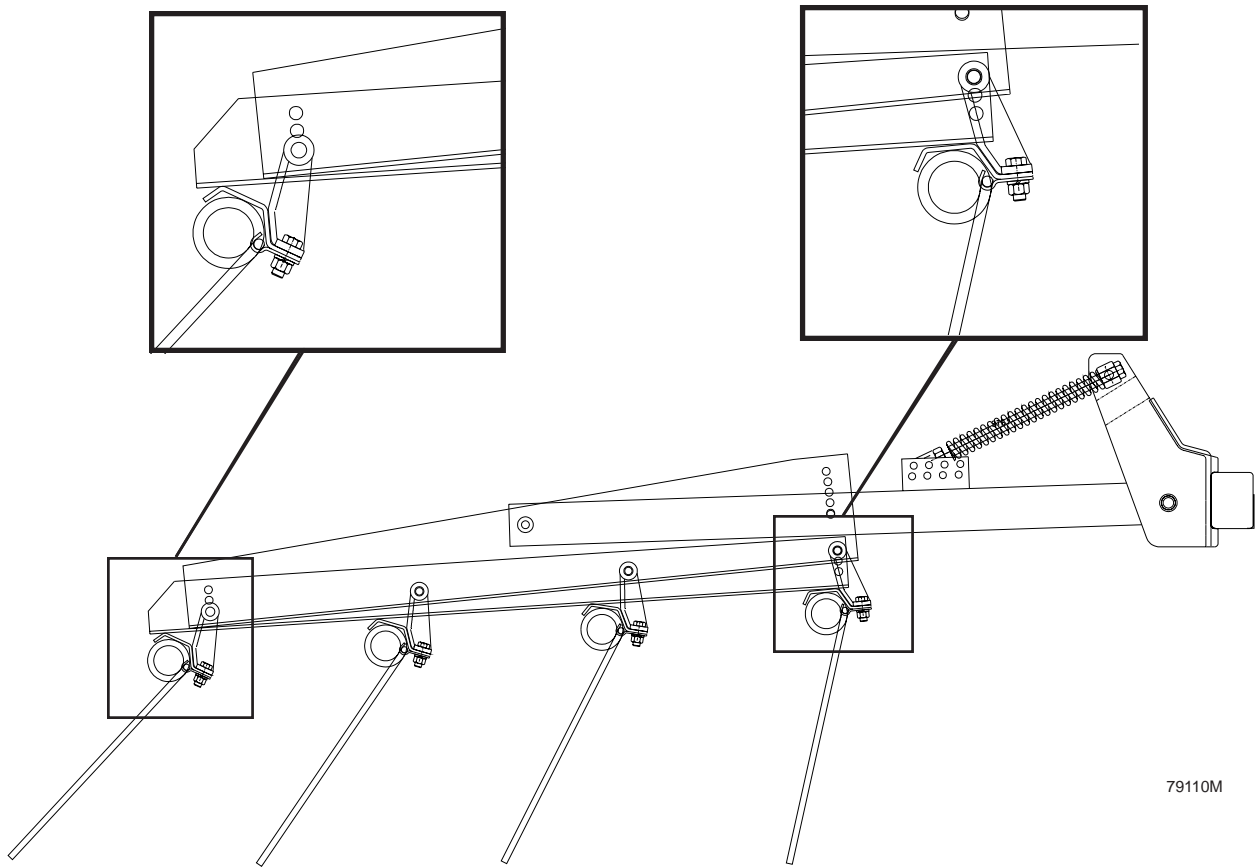
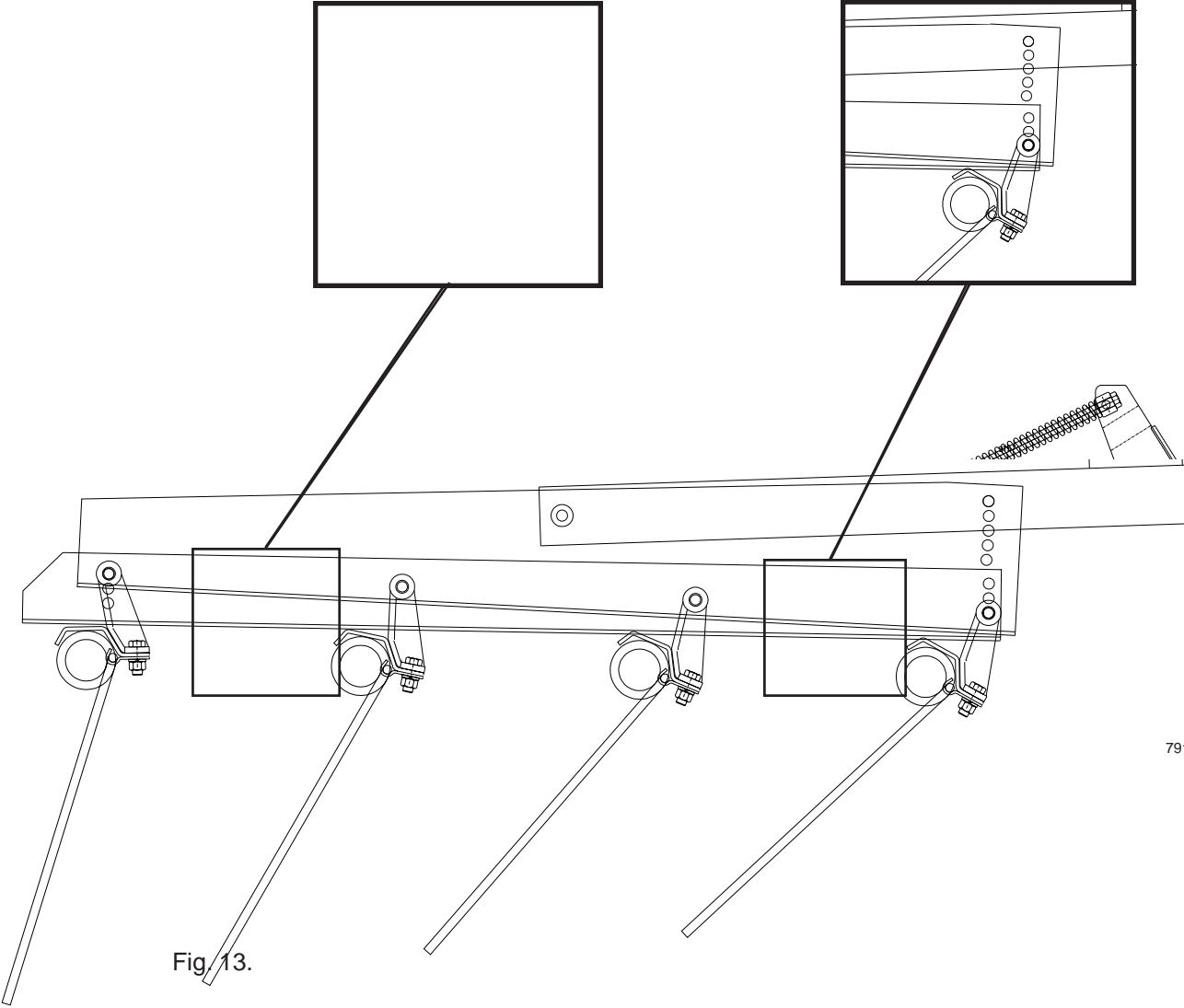

Fig. 12.

By mounting in the opposite holes in the tine angle bracket assembly as shown in Fig. 13. The reverse positioning is possible. The front and rear tine angle settings can be set the same or different depending on the finishing desired. For most applications the tine angle should be set the same at the adjustment points.



OPERATION

79110N

4 BAR FORMED CHANNEL COIL TINE SECTION

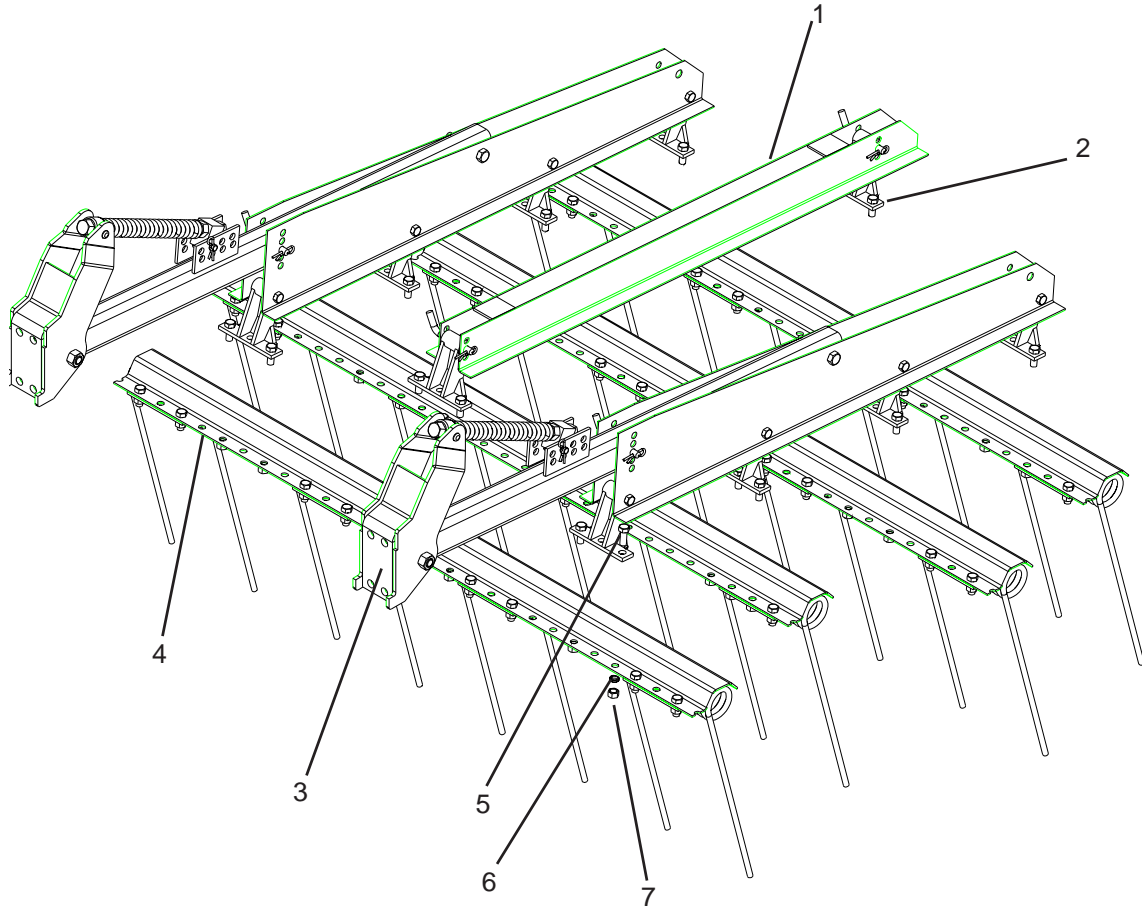

67191A

COMPLETE SECTIONS

67190	4HAC 4-1/2 FT
67191	4HAC 6 FT (SHOWN)
67192	4HAC 7-1/2 FT
221108	4HAC CP 4-1/2 FT
221109	4HAC CP 6 FT
221110	4HAC CP 7-1/2 FT

ITEM	PART NO	DESCRIPTION
1	67187	TINE ANGLE BRACKET
2	68578	PIVOT BRACKET
3	68201	HARROW ARM ASSEMBLY
	221107	CP HARROW ARM ASSY
4	67764	4BAR HA (18) HD 4-1/2 FT
	67765	4BAR HA (18) HD 6 FT
	67766	4BAR HA (18) HD 7-1/2 FT
5	88554	1/2NCx1-1/4 GR5 BOLT
6	88303	1/2 LOCK WASHER
7	88104	1/2NC NUT

PARTS

HARROW SECTION BAR

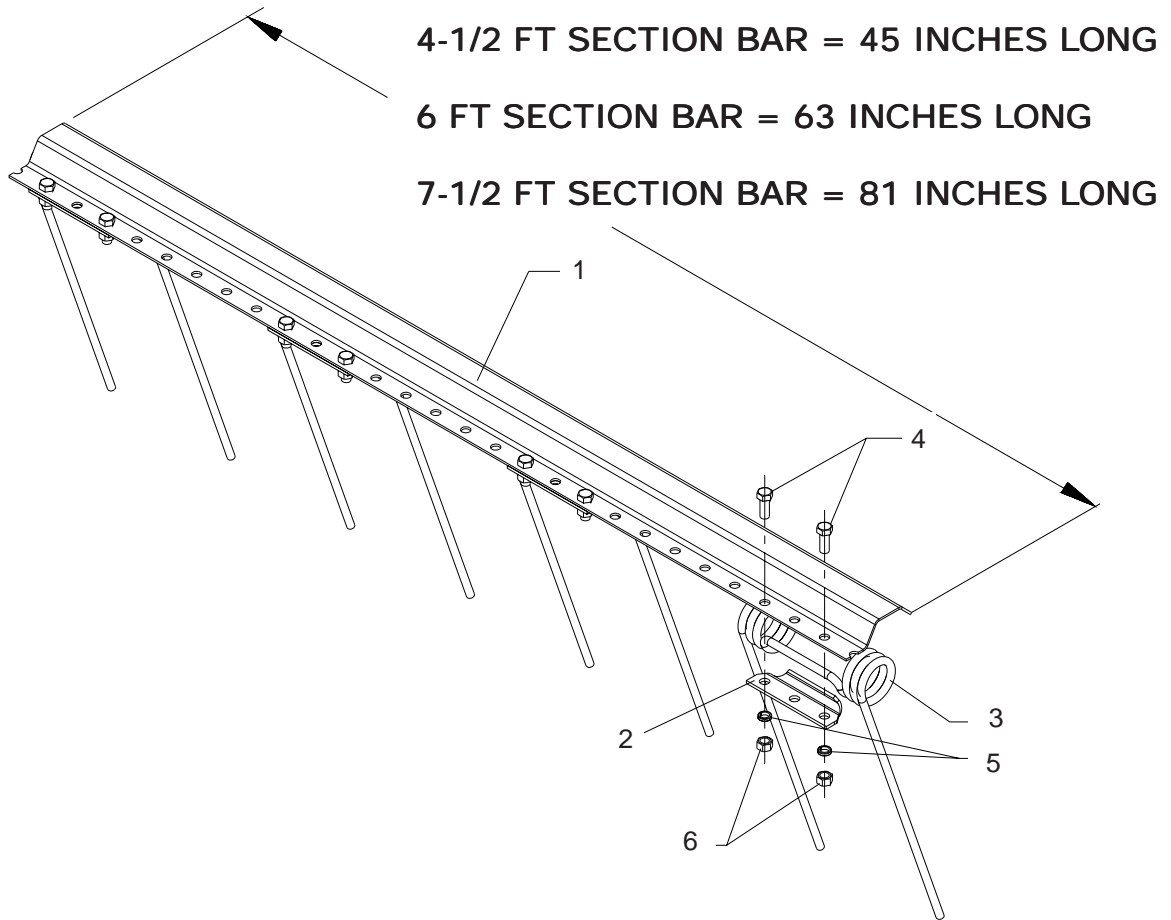

67765A

COMPLETE SECTION BARS

67764	4BAR HA(18)HD 4-1/2FT
67765	4BAR HA(18)HD 6FT
67766	4BAR HA(18)HD 7-1/2FT

ITEM	PART NO	DESCRIPTION
1	67883	4-1/2FT SECTION BAR
	67884	6FT SECTION BAR
	67885	7-1/2FT SECTION BAR
2	67062	TINE CLAMP
3	67886	7/16 x18x9 HARROW SPRING
4	88554	1/2NCx1-1/4 GR5 HEX BOLT
5	88303	1/2 LOCK WASHER
6	88104	1/2NC NUT

PARTS

HARROW ARM ASSEMBLY

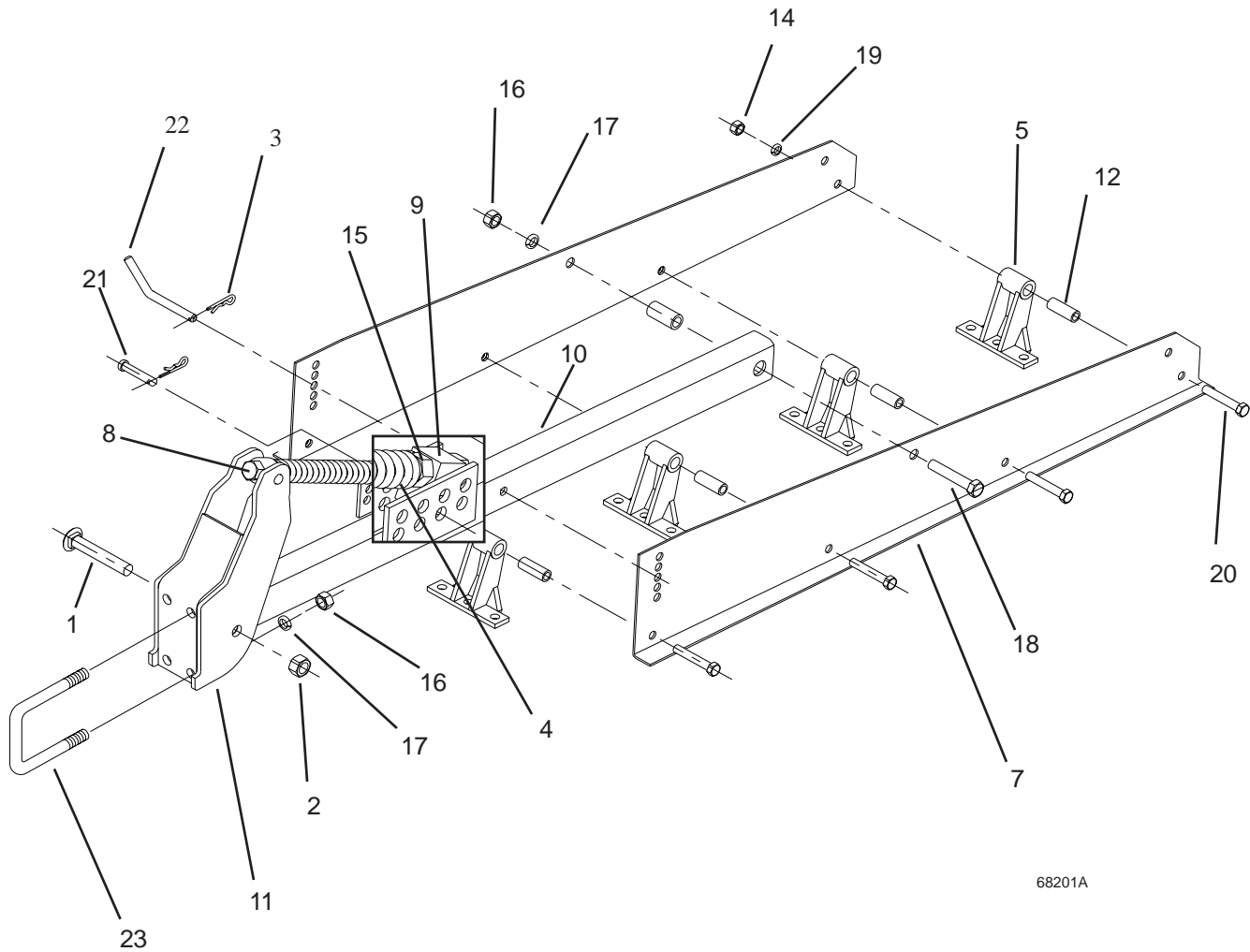

68201A

PARTS

ITEM	PART NO	DESCRIPTION	ITEM	PART NO	DESCRIPTION
	68201	FC HARROW ARM ASSY	13	67189	SPACER 1"OD
	221107	CP HARROW ARM ASSY	14	88104	1/2NC NUT
1	68575	SHANK CARRIAGE BOLT	15	88110	3/4NC NUT
2	22463	3/4NF GRC TOP LOCK NUT	16	88126	5/8NC NUT
3	23039	HAIRPIN COTTER 2.69"	17	88129	5/8 LOCK WASHER
4	68581	COMPRESSION SPRING	18	88292	5/8NCx3-1/2 GR5 BOLT
5	68578	PIVOT PLATE	19	88303	1/2 LOCK WASHER
6	222100	BAR HANGER - RIGHT	20	88541	1/2NCx3 GR5 BOLT
7	222101	BAR HANGER - LEFT	21	89275	1/2"OD x 2-1/2 CLEVIS PIN
8	67076	3/4NCx16.5 SPECIAL BOLT	22	23048	PIN
9	221981	MOUNT	23	88501	5/8NCx4x4-1/4 U-BOLT (FC)
10	67185	HARROW ARM		88145	5/8NCx4x5-1/4 U-BOLT (CP)
	220936	HARROW ARM - LONG			
11	67186	HARROW ANCHOR			
12	67188	SPACER .75OD			

FC= FIELD CULTIVATOR
CP= CHISEL PLOW

ANGLE TINE BRACKET

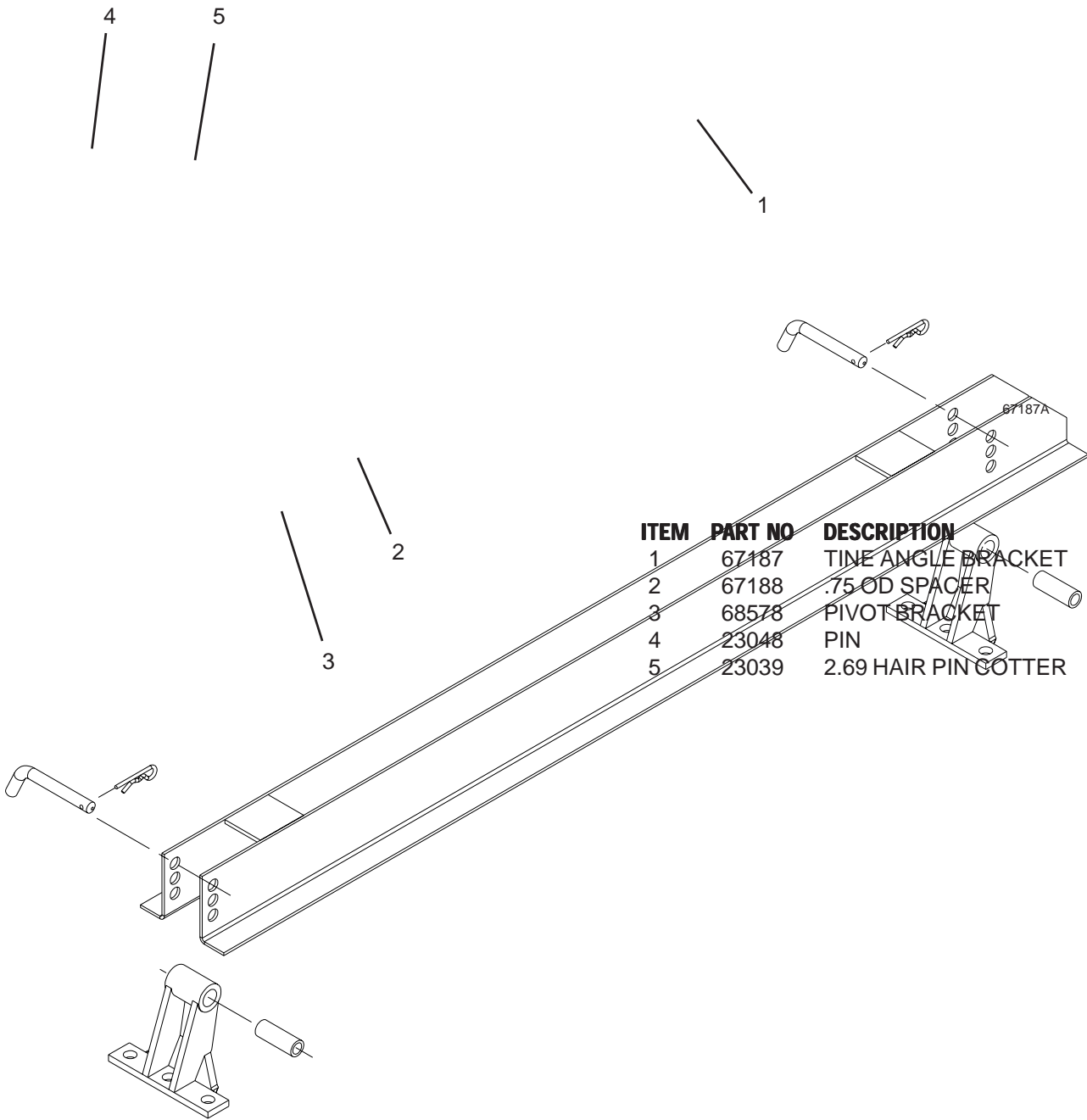

ITEM	PART NO	DESCRIPTION
1	67187	TINE ANGLE BRACKET
2	67188	.75 OD SPACER
3	68578	PIVOT BRACKET
4	23048	PIN
5	23039	2.69 HAIR PIN COTTER

PARTS

HARROW EXTENSIONS

HALF TOOTH EXTENSION

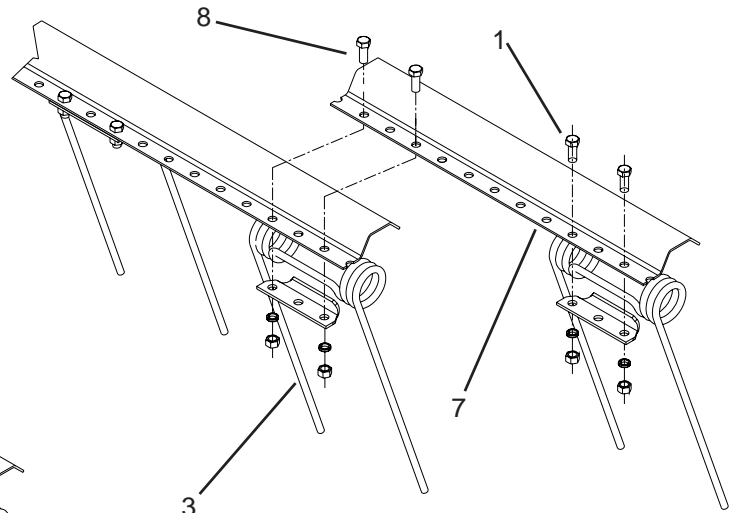
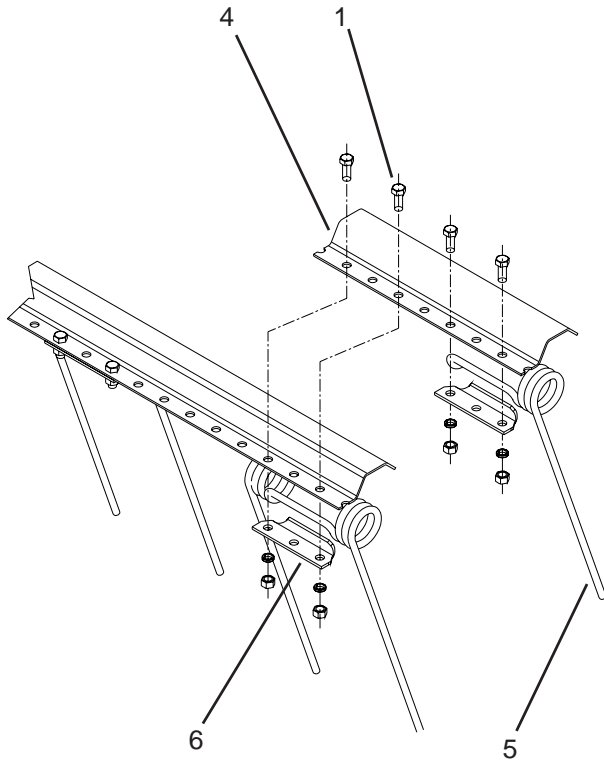

79209.PLT

FULL TOOTH EXTENSION

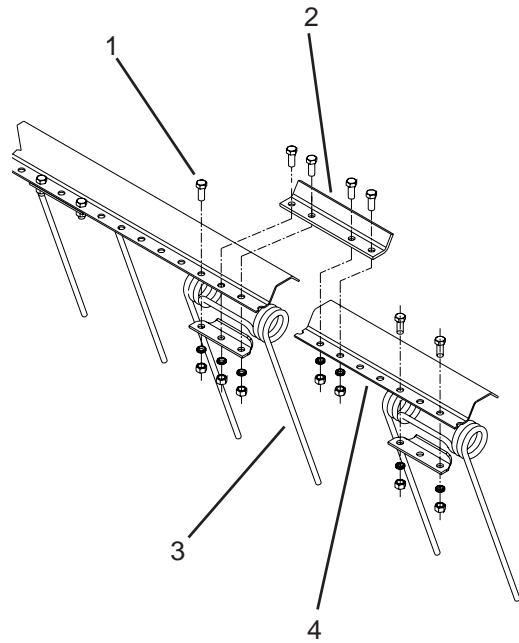

FULL TOOTH EXTENSION (NON-CURRENT)

ITEM	PART NO	DESCRIPTION
1	88554	1/2NCx1-1/4 GR5 BOLT
2	68203	EXTENSION CONNECTOR (NON-CURRENT)
3	67886	7/16x18x9 HARROW SPRING
4	68202	FULL EXTENSION (18")
5	221970	LEFT HALF SPRING (SHOWN)
	221971	RIGHT HALF SPRING
6	67062	TINE CLAMP
7	233305	TOOTH CHANNEL EXTENSION (27")
8	88475	1/2NCx1-1/2 GR5 BOLT

PARTS