

OPERATOR'S MANUAL

WIL-RICH 2900 STRAIGHT MOLDBOARD PLOW

SERVICE & ASSEMBLY

Wil-Rich
P.O. Box 1030
Wahpeton, ND 58074

WARRANTY VALIDATION AND DELIVERY REPORT

Your new machine is covered by a warranty that appears in your Operator's Manual. To initiate the warranty, this Delivery Report must be completed at the time of delivery and promptly returned to Wil-Rich.

IMPORTANT: Failure to do so within 10 days, or providing false information on this Delivery Report will invalidate the warranty.

NOTE: ALL OF THE FOLLOWING INFORMATION IS IMPORTANT AND IS KEPT AS A PERMANENT RECORD.

PLEASE PRINT OR TYPE ALL INFORMATION LEGIBLY!

COMPLETE UNIT DESCRIPTION _____
(Include model description and size of unit.)

SERIAL NUMBER _____ DELIVERY DATE _____

DEALER _____ OWNER _____

ADDRESS _____ ADDRESS _____

CITY _____ CITY _____

STATE _____ ZIP CODE _____ STATE _____ ZIP CODE _____

TELEPHONE NO. _____

NAME OF DISTRIBUTOR _____
(If Applicable)

1. The equipment is set up properly and is in good operating condition.

2. Owner has been instructed by the dealer in the proper use of all safety devices. Owner has also been informed of all safety warnings on the equipment and has been advised to read the Operator's Manual.

3. Owner has received instructions by the dealer on the proper field adjustment and maintenance procedures.

4. Owner has received the proper Operator's Manual and has been advised to read the same before operating the equipment.

Owner's Signature _____ Date _____

Dealer's Signature _____ Date _____

Personal safety is important!

All personnel involved with the assembly and/or operation of this equipment must be informed of proper safety procedures. Operator's and assembly manuals provide the necessary information. If a manual is lost for a particular implement, order a replacement at once. Operator's and assembly manuals are available at no charge upon request.

Address inquires to:

Wil-Rich

P.O. Box 1030

Wahpeton, ND 58074

PH (701) 642-2621 FAX (701) 642-3372

SAFETY

Safety decals appear at various locations on your machine. These decals are provided for your safety and should be kept clean. Replace any decal that becomes worn, damaged, painted over, or otherwise difficult to read. Replacement decals are available through your Wil-Rich dealer.

BEFORE OPERATING

Use extreme care when making adjustments.

When working under or around the machine always lower shanks to the ground.

After servicing, be sure all tools, parts, or servicing equipment is removed from the machine.

Make sure that there is no one near the machine just before operating and during operation.

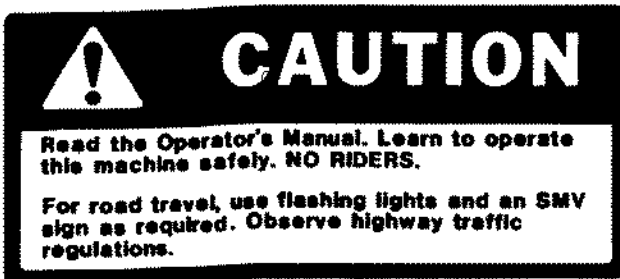

DURING OPERATION

Reduce speed when cornering on field ends and when operating on or across dead furrows.

Do not attempt to remove any obstruction while the machine is in motion.

Use extreme care when operating close to ditches, fences, or on hillsides.

No one other than the operator should ride on the tractor.

Before and during operation be sure no one is on or around the implement. Serious injury can result from improper use.

Hydraulic fluid escaping under pressure can have enough force to penetrate the skin. Hydraulic fluid may also infect a minor cut or opening in the skin. If injured by escaping fluid, see a doctor at once. Serious infection or reaction can result if medical treatment is not given immediately. Make sure all connections are tight and that hoses and lines are in good condition before applying pressure to the system. Relieve pressure before disconnecting the lines or performing other work on the hydraulic system. To find a leak under pressure use a small piece of cardboard or wood. Never use hands.

ON-HIGHWAY OPERATION

Always place the machine in the transport position.

Comply with your state and local laws governing highway safety when moving machinery on a highway.

Reduce road speed on corners.

Drive at a reasonable speed to maintain complete control of the machine at all times.

A S.M.V. emblem should be used at all times while traveling on public roads.

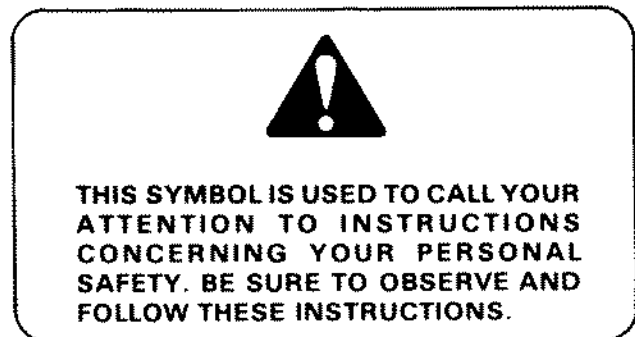

TO THE OWNER

It is the responsibility of the user: To read the Operator's Manual and comply with the safe and correct operating procedure as: Pertains to the operation of the product; and to lubricate and maintain the product according to the information outlined in the Operator's Manual.

The user is responsible for inspecting his machine, and for having parts repaired or replaced when continued use of the product would cause damage or excessive wear to the other parts.

The word NOTE is used to convey information that is out of context with the manual text; special information such as specifications, techniques, reference information, and other information of supplementary nature.

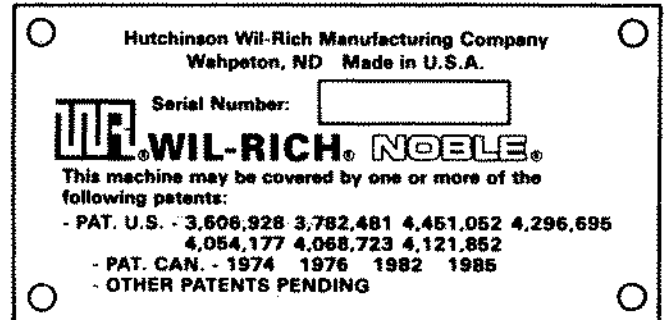

When in need of parts, always specify the model and serial numbers, including prefix and suffix letters. Write these numbers in the spaces provided. The serial number plate is located on the left side of the front furrow wheel corner.

CONTENTS

PREPARATION	1
ADJUSTING AND OPERATING	2-7
SETTING UP	8-16
OPTIONAL EQUIPMENT	17-18
LUBRICATION	19
TROUBLESHOOTING	20-21

MODIFICATIONS

It is the policy of Wil-Rich Operations to improve its products whenever possible and practical to do so. We reserve the right to make changes, improvements, and

modifications at any time without incurring the obligation to make such changes, improvements, and modifications on any equipment sold previously.

ADJUSTING AND OPERATING

PREPARATION

Before using your Wil-Rich plow, a careful inspection should become routine. A check should be made to insure that all hardware is securely tightened and moving parts properly lubricated.

TRACTOR PREPARATION

Refer to tractor's operator's manual furnished with tractor for recommended adjustments and weight distribution.

TRACTOR TIRES

For in-furrow plowing the recommended minimum wheel setting is 30" from center line of tractor to inside of each drive wheel. (See Fig. 1) The left wheel may be set out wider for additional stability.

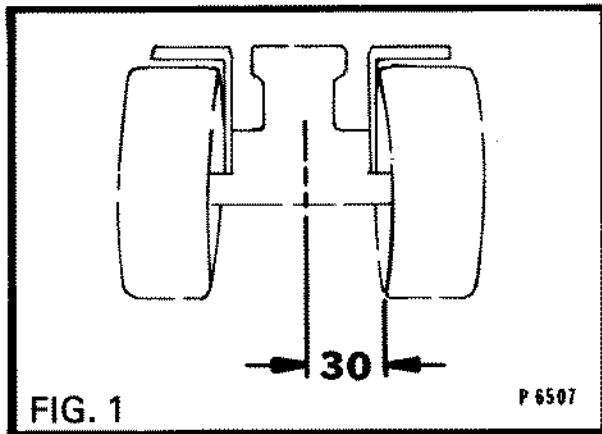

The recommended maximum overall width of the tractor tires with or without duals is 142" (see fig. 2). Operating conditions will determine if duals can be used.

See your tractor's operator's manual for recommended tire pressures of main tires and duals.

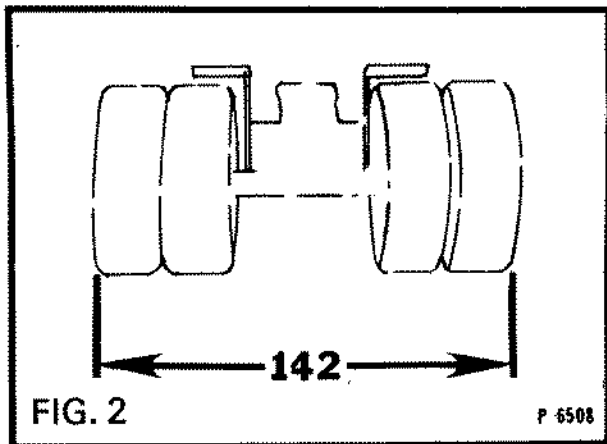

TIRE INFLATION

The use of the proper air pressure is the most important factor in satisfactory performance and maintenance of implement tires. Underinflation will damage the cord body of the tire and cause a series of diagonal breaks in the fabric in the sidewall area.

If the tire buckles or wrinkles, the air pressure should be increased to the point where the sidewalls remain smooth while operating.

WHEEL BOLTS

It is recommended that all wheel bolts be checked for tightness before using and again after one day of use. Paint or rust can work out causing the wheel to become loose. Check periodically to be sure the wheel bolts are tight.

BEARING ASSEMBLIES

Bearing assemblies should be checked periodically for looseness. A loose bearing will cause costly damage after a short period of time.

ATTACHING TO TRACTOR

The hitch point on the straight moldboard plow can be adjusted 25 to 71 inches from the furrow wall. When the hitch is assembled as shown in Fig. 3 the range of adjustment is 45 to 71 inches from the furrow wall. By reversing the hitch pole and pole brace, the hitch point can be moved from 25 to 48 inches from the furrow wall. The correct hitch point, which is affected by field conditions, will determine which way the hitch is used.

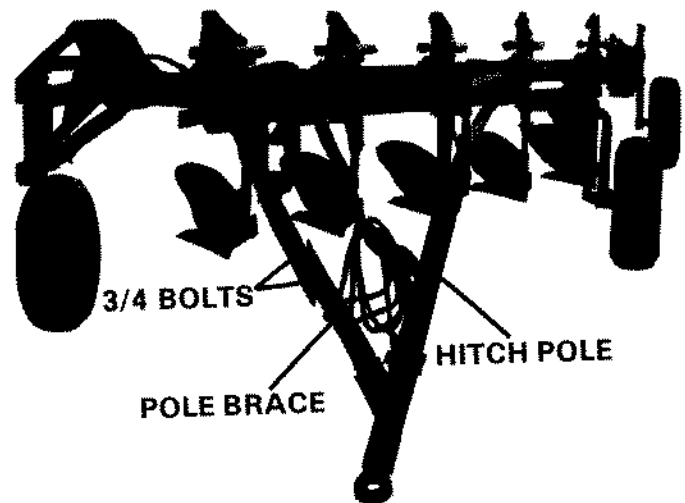

FIG. 3 HITCH

P1-75460

ADJUSTING AND OPERATING

TRANSPORTING

A SMV slow moving vehicle bracket is provided on the rear portion of tailsection. The SMV emblem should be used at all times while on public roads.

Drive at a reasonable speed to maintain complete control of the machine at all times.

Comply with your state and local laws governing highway safety and with any regulations which cover moving machinery on the highway in your area.



NOTE: ALWAYS LOCK THE REAR TAILWHEEL WHEN OPERATING THIS PLOW ON THE ROAD OR WHEN TRANSPORTING THE UNIT TO AND FROM THE FIELD. (FIG. 4) DO NOT MAKE SHARP TURNS WHEN TAILWHEEL IS LOCKED.

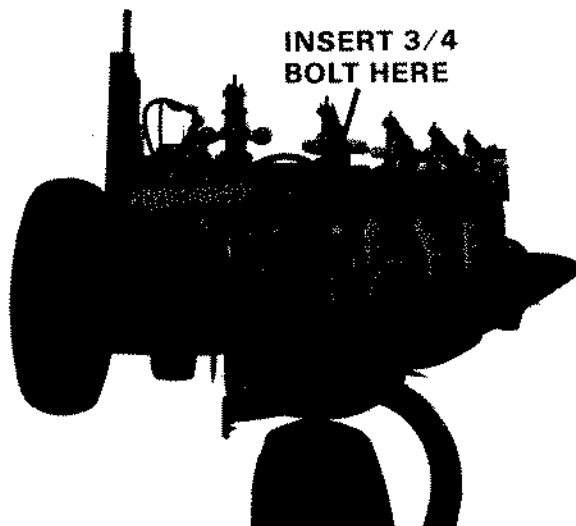

FIG. 4 TAILWHEEL

P1-75462

NOTE: NEVER DISCONNECT THE PLOW FROM THE TRACTOR WHILE IN THE RAISED POSITION. LOWER PLOW TO GROUND HYDRAULICALLY BEFORE DISCONNECTING THE PLOW HITCH.



REMOVING PROTECTIVE COATING FROM BOTTOMS

Plow bottoms are polished and coated to prevent rusting before leaving the factory. Good work cannot be accomplished until this coating is removed.

The black, protective coating on the bottoms will quickly wear away in most soils; however, for soils which scour with difficulty, it is advisable to remove the coating before attempting to plow. For this purpose, use a paint remover and wipe or scrape off.

NOTE: DO NOT PERMIT SMOKING OR AN OPEN FLAME WHERE COMBUSTIBLE FUELS ARE BEING USED TO REMOVE THE PROTECTIVE COATING. KEEP THE WORK AREA WELL VENTILATED.

If the plow is not to be used for a long period of time, scrape off the dirt, clean, and protect the polished surface of the bottoms with a liberal coating of mold-board bottom paint protector. These paints are a rust preventative; they apply easily and are easily scoured when the plow is again used. Heavy grease may be used to protect the bottoms for short periods of time.

SCOURING

If the plow bottoms do not scour immediately, it is because the soil is rather sticky and you will have to wait until the bottoms have taken a land polish. This may require a few rounds or in very sticky soil, a few days. To obtain this land polish, it is recommended that you run the plow rather shallow and fast. It is also advisable to set the coulter far to the outside of the landside and not too deep. Sometimes it is necessary to remove the coulter entirely so as to obtain the maximum pressure on the plow bottom.

ADJUSTING AND OPERATING

FRONT FURROW WHEEL

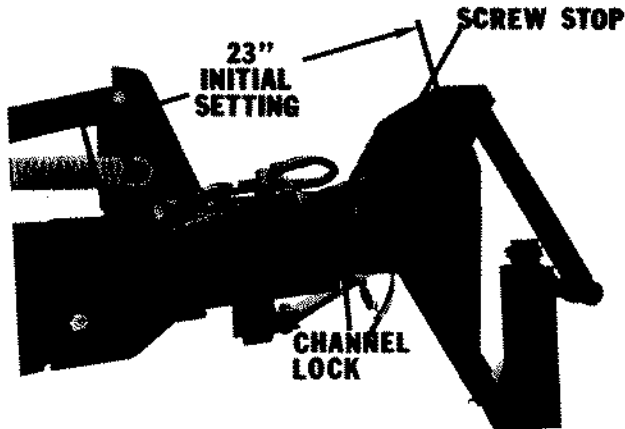

FIG. 5

PI-75357

When striking out, the furrow wheel cylinder should be set to its shortest retracted length. This is accomplished by turning the screw stop against the cylinder rod yoke.

After striking out the screw stop is to be adjusted so the retracted length of the cylinder is approximately 23" as shown in illustration. (See Fig. 5) This setting may require a later adjustment.

A thumbscrew is provided with the screw stop to insure the desired cylinder setting is held.

A channel lock is always to be used when transporting.

LANDWHEEL

There are two settings on the landwheel cylinder anchor. The highest setting should be used for plowing depths up to 8". The lower setting is used for plowing depths up to 12" (See Fig. 6).

For initial setting, place the cylinder anchor in its highest setting and adjust the screw stop approximately one half of its total travel away from the cylinder rod yoke. This will set the plowing depth at approximately 8".

A thumbscrew is provided with the screw stop to insure the desired cylinder setting is held.

A channel lock is always to be used when transporting.

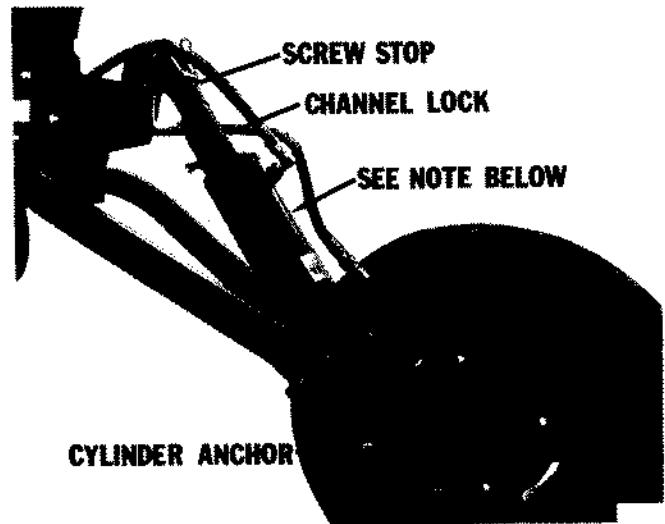
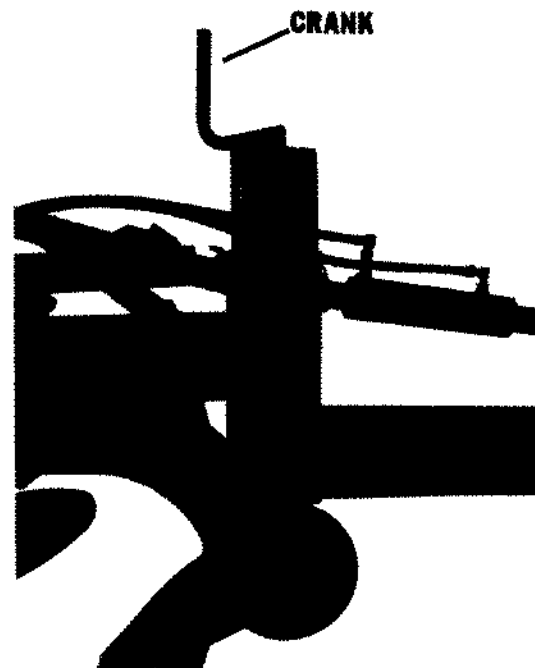

FIG. 6

PI-75463

NOTE: INSTALL LANDWHEEL CYLINDER ONLY AS SHOWN. IMPROPER PLACEMENT WILL RESULT IN CYLINDER ROD DAMAGE. (SEE FIG. 6)

GAUGE WHEEL



TIRE AND WHEEL REMOVED FOR BETTER VIEW.

FIG. 7

PI-75455

To set gauge wheel to desired plowing depth turn gauge wheel crank (See Fig. 7) as required. When plow is in operation the gauge wheel should be supporting approximately 60 percent of the rear end weight.

ADJUSTING AND OPERATING

TAILWHEEL

The tailwheel is to be set when the plow is at the gauge wheel plowing depth. Turn the tailwheel cylinder screw stop in until contact is made with the cylinder. Then partially raise the tailwheel and turn the screw stop in one full turn. This adjustment will put approximately 40 percent of the rear end weight on the tailwheel. This weight serves to stabilize the rear of the plow while in operation (See Fig. 8).

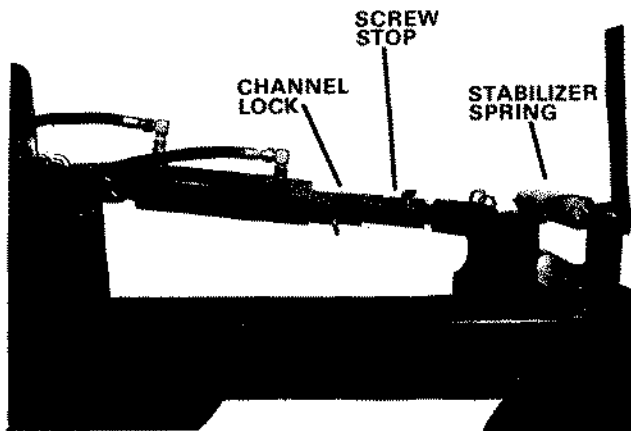

FIG. 8

PI-75452

The tailwheel serves to carry the rear end of the plow when transporting. Be sure the tire is inflated to the recommended air pressure before making adjustments.

A channel lock is to be used to lock tailwheel cylinder in transport position.

Tighten stabilizer spring to prevent tailwheel from oscillating while plowing and to increase stability of plow while turning.

LEVELING PLOW

FRONT-TO-REAR

Before the plow can be properly leveled, the strike out round must be made. Set the desired depth of the rear bottom with the gauge wheel. Set the desired depth of the front bottom by setting the screw stop on the front furrow wheel cylinder.

SIDE-TO-SIDE

After the striking out round has been made and the plow has been leveled front to rear, the front 2 x 6 beam should be set horizontal with the ground when it is in field position. The screw stop on the landwheel cylinder is used to set the 2 x 6 beam. Its setting is entirely dependent on the plowing depth. (See Fig. 9)

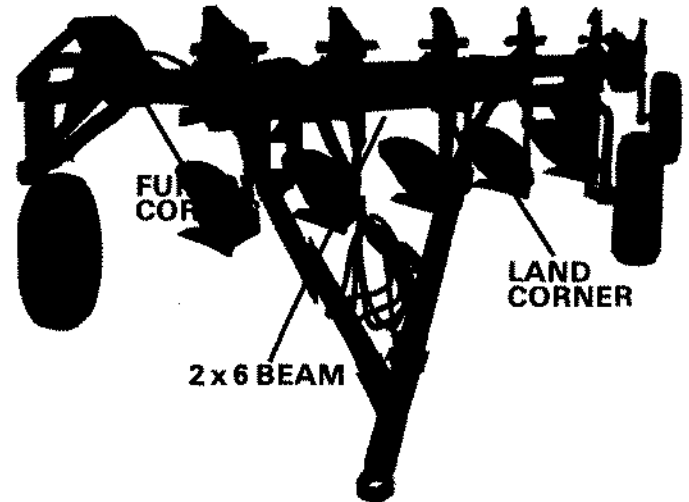

FIG. 9

PI-75460

Setting the land corner lower than the furrow corner will give quicker penetration of the shares if needed.

DRAFT ADJUSTMENT

The draft of the plow is greatly effected by soil conditions, speed and depth of plowing, coulter settings, type of bottoms, etc. These all effect the hitch location. For example when plowing in light sandy soil at speeds greater than 4 mph a plow with general purpose bottoms has a tendency to over cut. This is due to the side loading of the moldboard when turning the soil. This side loading can be taken up by moving the hitch point closer to the furrow wall, or by the use of longer landsides and (or) double wear pads.

All hitching adjustments are effected also by the vertical leveling of the plow. The conditions which effect the operation of the plow can change from field to field and within the same field, so adjustments should be made to the average field conditions.

An in-furrow plow may require a revised tractor wheel setting, or the addition of ballast to the front or rear of the tractor.

The addition of a harrow or drill press to the plow must also be taken into account.

ADJUSTING AND OPERATING

AUTOMATIC RESET STANDARD

The trip shank assembly is designed to give total protection against rocks and other obstacles which are encountered while in operation.

The amount of force required to trip or fold the linkage is determined by the stop block setting.

The stop block maintains the linkage arms distance from center, shown as dimension (A), Fig 10

The stop block may be loosened and turned to any one of four positions. Decreasing distance (A) will increase the force required to trip the linkage arms.

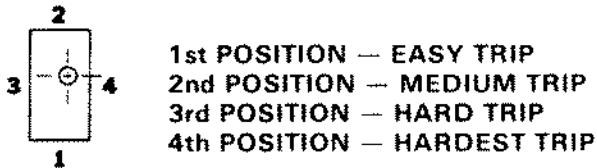

To change stop block use the following procedure:

1. Remove both reset springs.
2. Raise bottom several inches and block securely.
3. Loosen stop block bolt, turn block to desired position.
4. Reassemble.

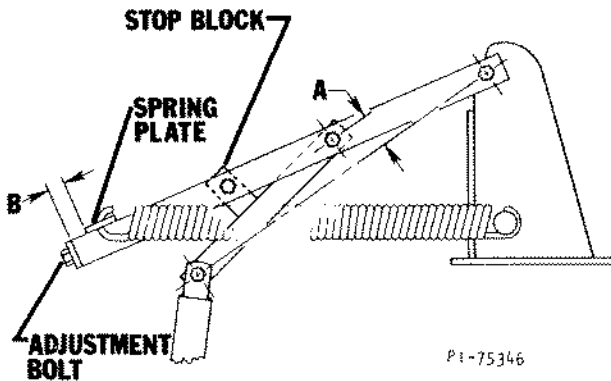

FIG. 10

P 6501

The spring tension may be adjusted with the adjustment bolt. Tightening the springs increases the force necessary to trip the linkage arms, it also increases reset force and resists "floating" or vertical rise of the bottom.

SUGGESTED SETTINGS.

In **average rock conditions** it is recommended the stop block be placed in the 2nd position and the springs be adjusted to a distance, at (B), of 3/4.

In **extremely heavy rock conditions** it is recommended the stop block be placed in the 1st position and the springs be adjusted to a distance, at (B), of 1-1/4.

For **heavier draft conditions** it is recommended the stop block be placed in the 3rd position and the springs be adjusted to a distance, at (B), of 1/2.

Only for extremely heavy soil conditions and relatively rock free fields it is recommended the stop block be placed in the 4th position and the springs adjusted at (B) for the highest reset power and heaviest draft resistance as required.

For added reset pressure, reverse spring plate.

NOTE: DO NOT SET THE TRIP TIGHTER THAN NEEDED TO RESIST NORMAL PLOWING LOAD. THIS WILL INCREASE SHOCK LOAD, CAUSING EXTRA WEAR ON SHARES, BOLTS, AND ETC.

The trip shank stop bolt (See Fig. 11) can be adjusted a limited amount to help vertical alignment of the bottoms. Do not extend the bolt over 1/2".

Trip shank pivot bolts (See Fig. 11) are adjustable to eliminate side play in the shank assemblies. Remove cotter pins and tighten until the side play is reduced, but still loose enough to allow the shank to move freely.

It is recommended the bottoms be checked for side play and these nuts adjusted after the first few days of field use.

Stop bolts tend to work out during use so keep locknut tight and check all bolts regularly.

ADJUSTING AND OPERATING

NOTE: USE CAUTION WHEN PLOWING IN FIELDS WITH LARGE ROCKS, WHICH PROTRUDE SIX INCHES OR MORE ABOVE THE SURFACE.

NOTE: DO NOT OVER TIGHTEN PIVOT BOLT SINCE THIS MAY CAUSE A BOTTOM TO HANGUP WHEN TRIPPED.

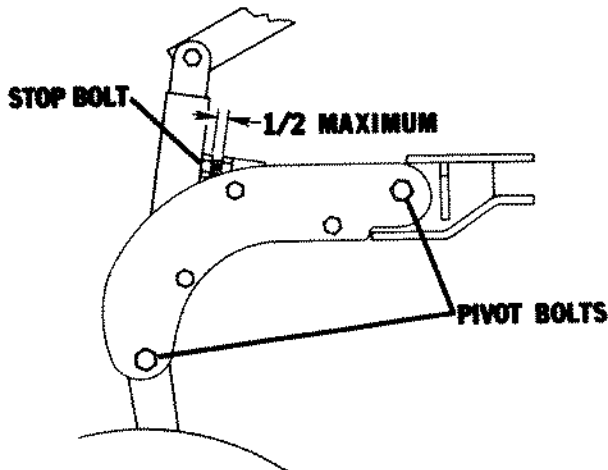

FIG. 11

P1-75360

NOTE: THE SPRINGS AND BARS WHIP AT A VERY FAST RATE FORWARD, MAKING IT DANGEROUS TO RIDE ANYWHERE ON THE PLOW FRAME.

THE TRIP ASSEMBLIES OPERATE VERY RAPIDLY AND ARE POTENTIALLY DANGEROUS TO BE NEAR AT ANY TIME WHILE PLOWING.

SHOULD DIRT OR TRASH CAUSE A UNIT TO HANGUP, STAY CLEAR OF THE AREA NEAR THE UNIT. TO REMOVE THE OBSTRUCTION, USE A LONG POLE OR HOOK.

SHEAR BOLT STANDARD

The shear bolt trip assembly is designed to protect the bottom assembly and plow from damage when plowing in light rock conditions. When an obstruction is encountered while plowing, the shear bolt (A) will absorb the shock load through shear and allow the bottom to rise above the obstruction before damage is done.

To reset the bottom assembly, raise the plow out of the ground far enough to allow the trip assembly to swing down into plowing position. Replace the shear bolt with a special Wil-Rich replacement shear bolt (A-5243) and tighten to approximately 50 foot pounds torque (See Fig. 8).

Because this trip assembly is designed for use in area's of light rocks and the shock cushioning effect of the spring reset is not present, it is important you check all bolts and nuts on the shear bolt trip assemblies often enough to insure they are kept tight.

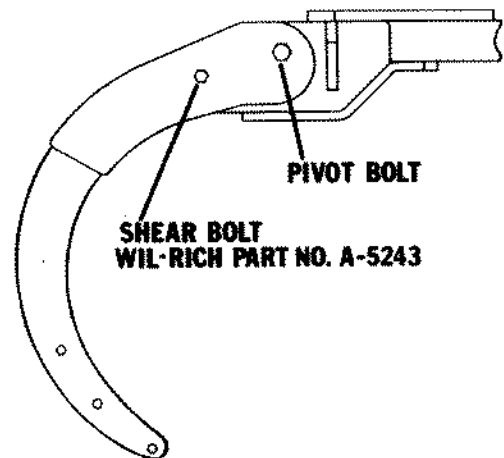

FIG. 12

P1-75361

NOTE: A STANDARD 5/8 X 3-1/2 GRADE 2 BOLT MAY BE SUBSTITUTED FOR THE WIL-RICH SHEAR BOLT.

BOTTOMS

NOTE: NEVER ALLOW THE SHARE, SHIN OR LAND-SIDE TO WEAR UNTIL THE FROG IS EXPOSED. WHEN PLOWING IN ABRASIVE OR ROCKY SOIL CHECK THE CONDITION OF THESE PARTS FREQUENTLY. PLOWING WITH WORN SHARES CAN RESULT IN A HARD RUNNING PLOW AND INCREASED FUEL COSTS.

ADJUSTING AND OPERATING

COULTER ADJUSTMENT

Coulters help cut the furrow slices vertically and also cut through the surface trash and aid in producing a clean furrow wall. Compression spring coulters are recommended for use with automatic reset standards and stony soil. The coulters are adjusted both vertically and side to side by slightly loosening the coulters shank clamp and adjusting the shank to the desired position. For normal conditions the coulters should be set to run approximately $\frac{1}{2}$ to $\frac{3}{4}$ of an inch to the left of the moldboard shin. In lighter crumbly ground a wider setting may be necessary in order to obtain a clean furrow wall. In sod or firmer soil the coulters may sometimes be set narrower. (See Fig. 13)

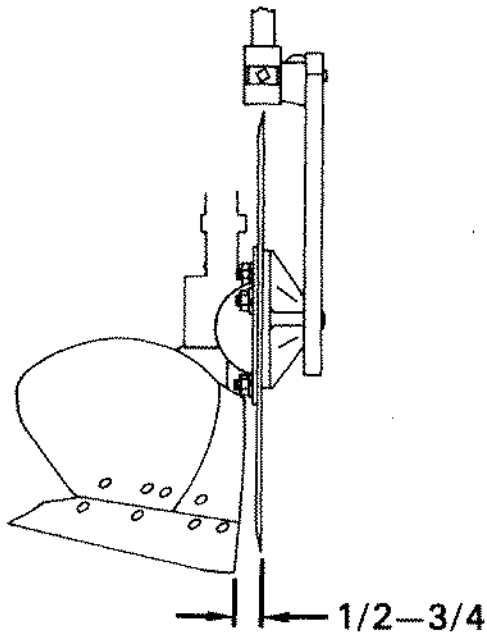

FIG. 13

PI-75369

A set collar is provided in the coulters yoke to prevent the coulters from swinging completely around. The collar should be adjusted to allow the coulters to swing approximately the same distance from side to side.

Once the rear coulters has been properly set to obtain a clean furrow wall, all other coulters should be set the same. For normal conditions coulters should cut one half the depth of plowing.

Coulters trip pressure can be increased by tightening the spring adjustment nut. (See Fig. 14).

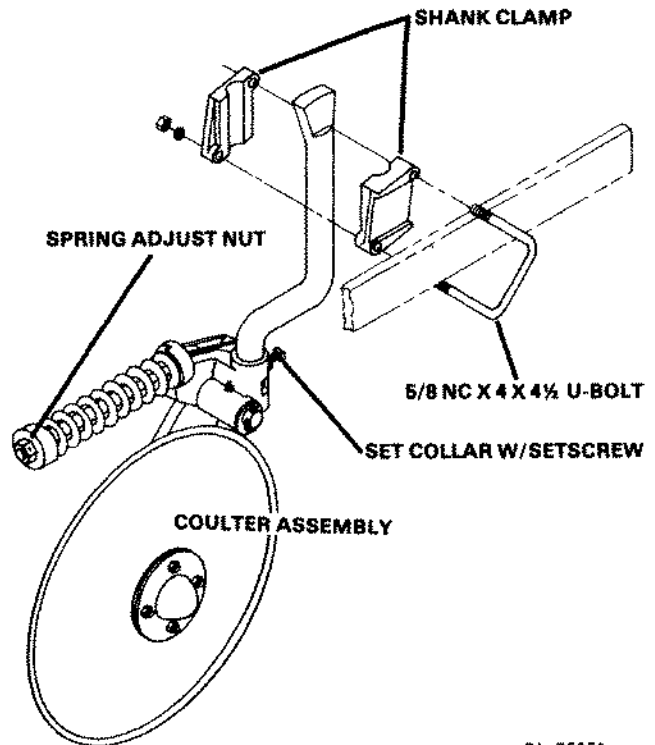

PI-75355

FIG. 14

NOTE: Care should be taken in the mounting of the coulters on the front bottom on units which have a front furrow wheel. Locate the coulters so that the center of the coulters blade is no more than eight inches in front of the point of the share. Also, the set collar should be adjusted so that the coulters cannot swing past the front of the share into the plowed ground more than one and one half inches. These restrictions are to insure that the front furrow wheel tire is not cut by the front coulters.

SETTING UP

Remove all wires and arrange the parts conveniently.

Wherever the terms "left" and "right" are used, it should be understood to mean from a position behind and facing the machine.

Lubricate all bearing and moving parts as you proceed and see that they work freely.

Bolts must be used in the holes in which they are found, or in the parts to which they are attached, unless otherwise shown.

When tightening bolts, they should be torqued to the proper number of foot-pounds as indicated in the table unless otherwise specified.

On new machines, all nuts and bolts should be rechecked after a few hours of operation.



GRADE 8



GRADE 5



GRADE 2

TORQUE IN FOOT POUNDS

BOLT DIA	3/8	1/2	5/8	3/4	7/8	1
HEX HEAD	9/16	3/4	15/16	1-1/8	1-5/16	1-1/2
UNC	2	18	45	89	160	252
	5	30	68	140	240	360
	8	40	100	196	340	528
UNF	2	21	51	102	178	272
	5	32	70	168	264	392
	8	48	112	216	368	544

PI - 75623

When replacing a bolt, use only a bolt of the same grade or higher.

Bolts with no markings are grade 2.

Grade 5 bolts furnished with the machine are identified by three radial lines on the head.

Grade 8 bolts furnished with the machine are identified by six radial lines on the head.

All U-bolts are grade 5.

NOTE: ALWAYS WEAR SAFETY GLASSES OR GOGGLES AND BE CAREFUL WHEN CUTTING WIRES AND STEEL BANDS AS THEY ARE UNDER TENSION AND WILL SPRING BACK WHEN CUT.

NOTE: CHECK YOUR TRACTOR'S HYDRAULIC FLUID LEVEL AFTER CYCLING HYDRAULICS AND FILLING NEW CYLINDERS AND LINES. REFILL IF NECESSARY.

GENERAL SEQUENCE OF ASSEMBLY

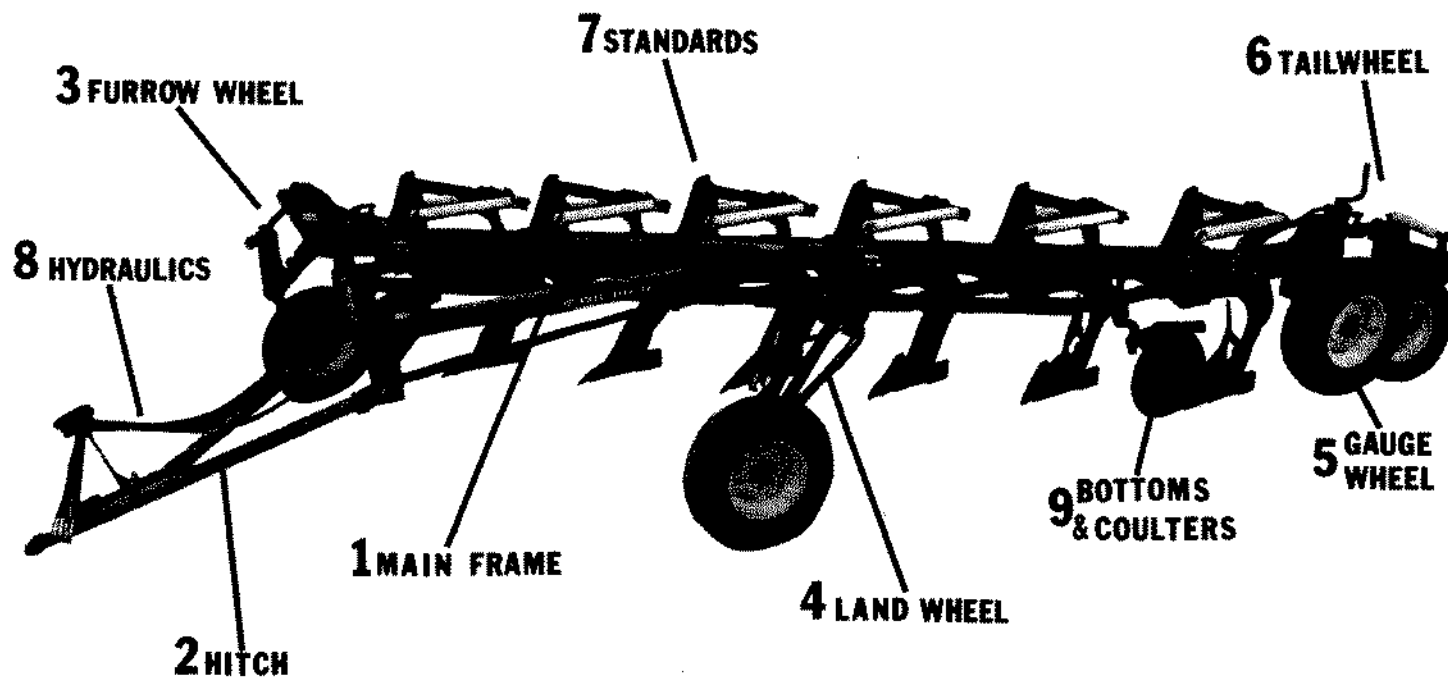

SETTING UP

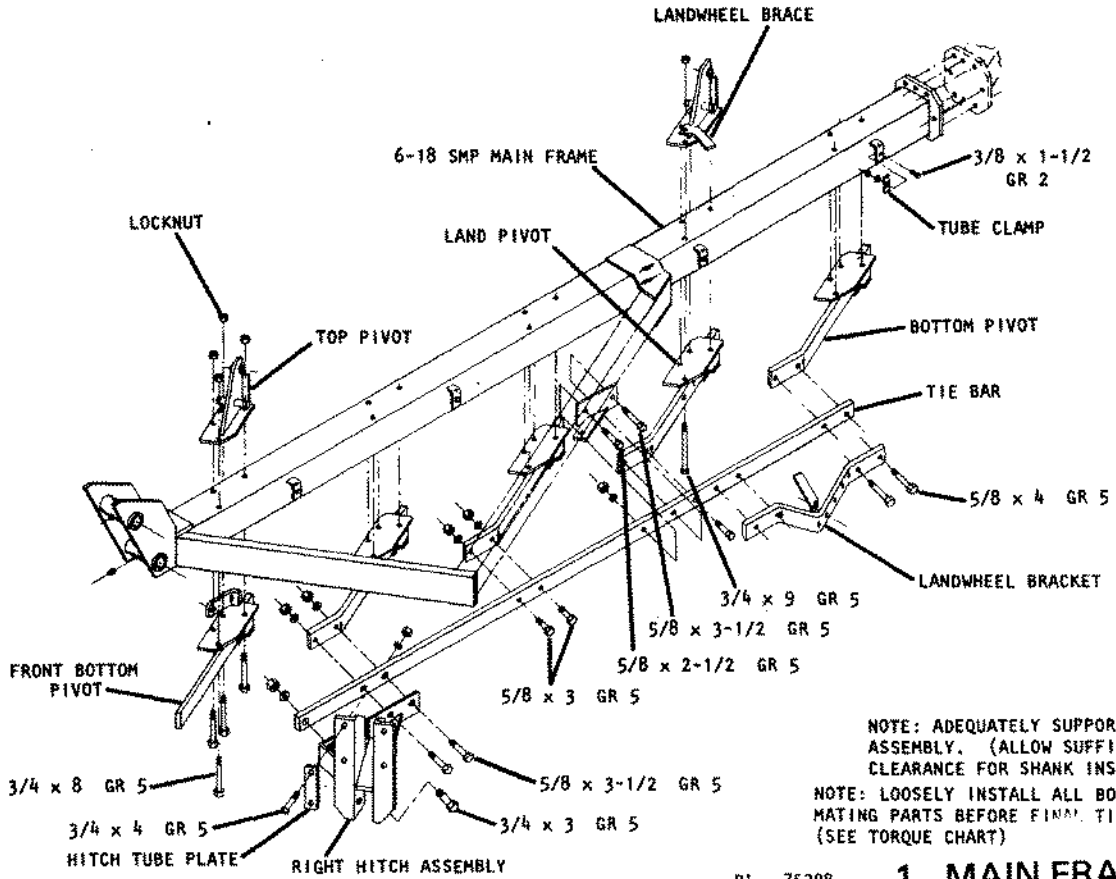

PI - 75398

1. MAIN FRAME

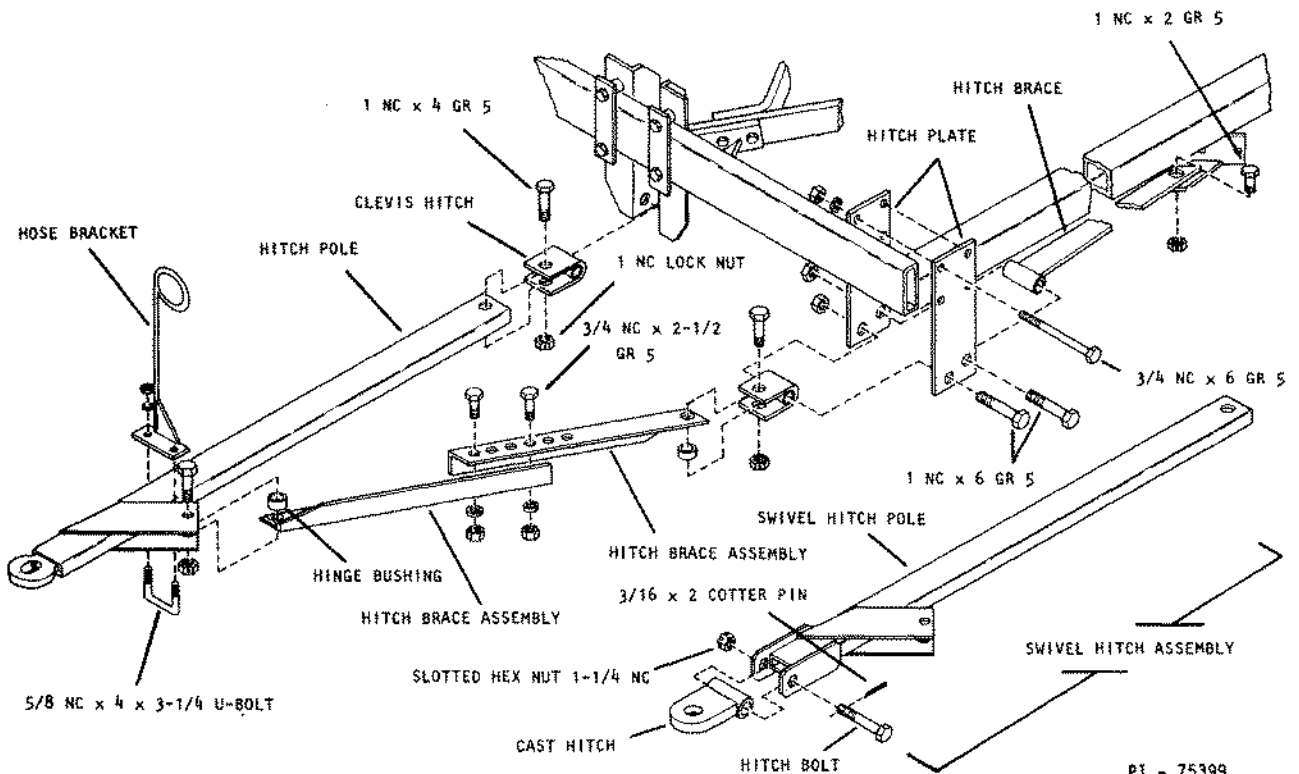

PI - 75399

2. HITCH

SETTING UP

3. FURROW WHEEL

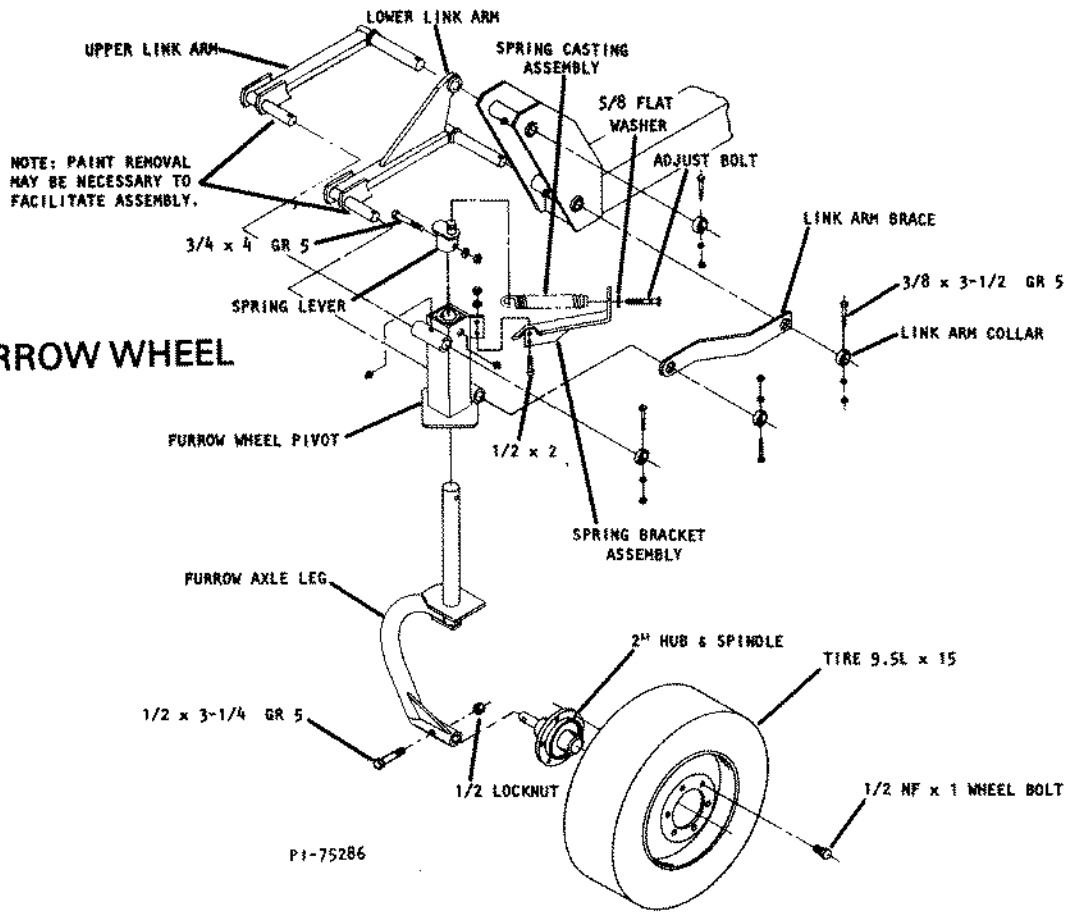

4. LAND WHEEL

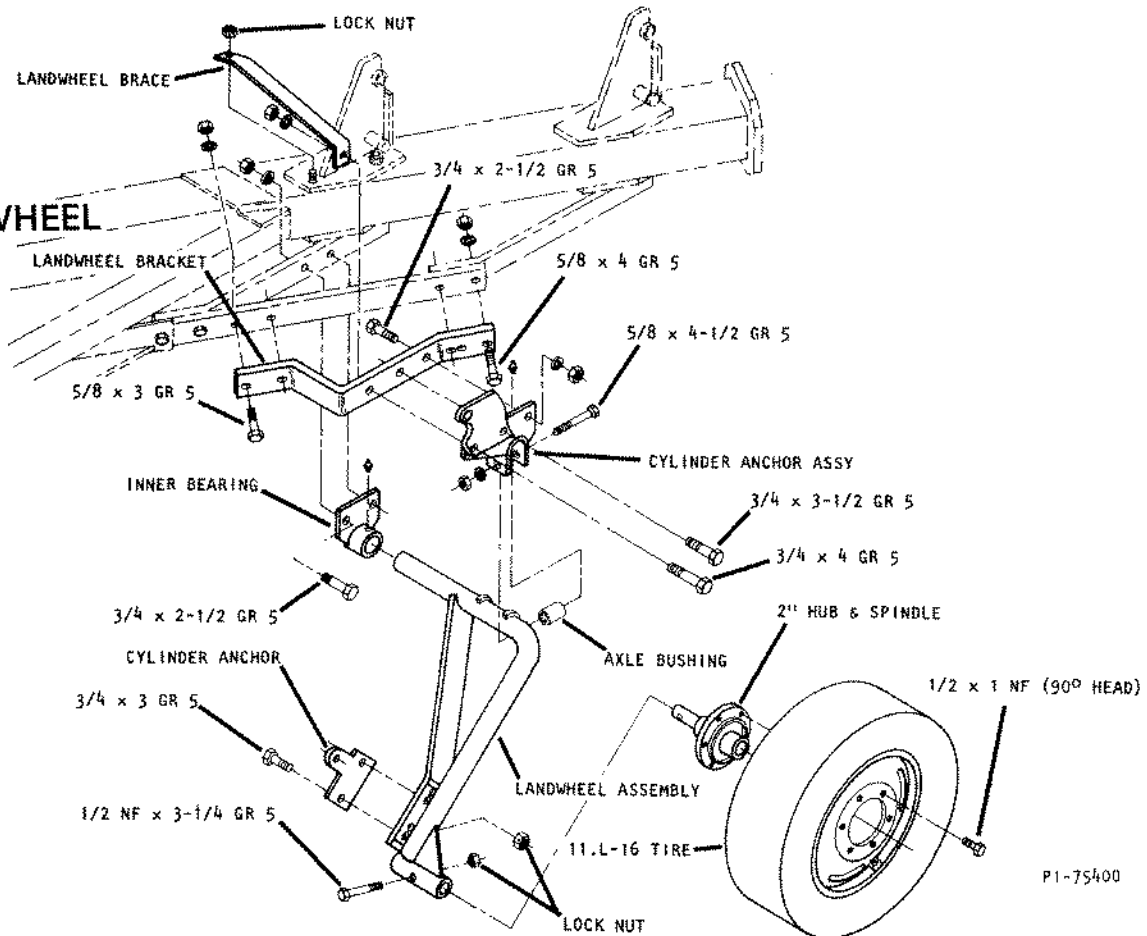

**SETTING UP
EXTENSIONS (IF REQUIRED, ASSEMBLE AT THIS TIME)
(SEE NOTE ON PAGE 18)**

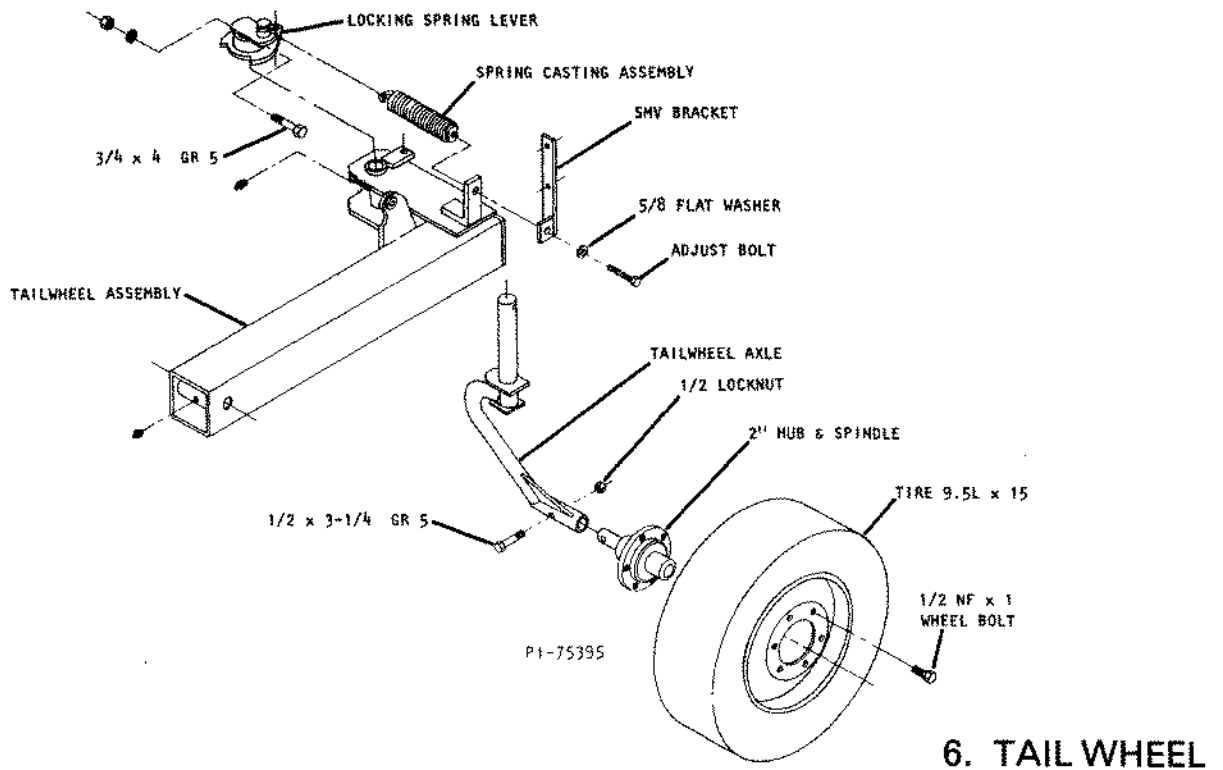
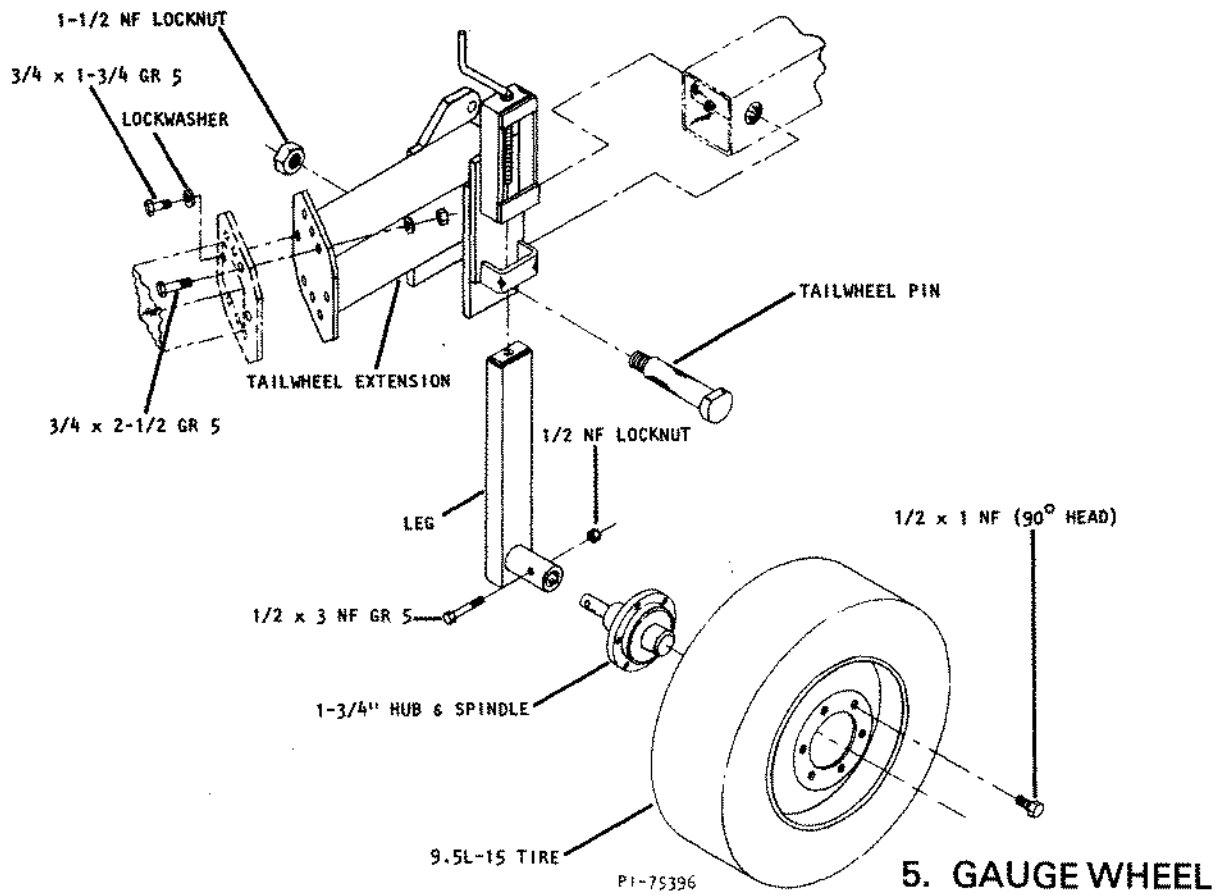

7. AUTOMATIC RESET STANDARD

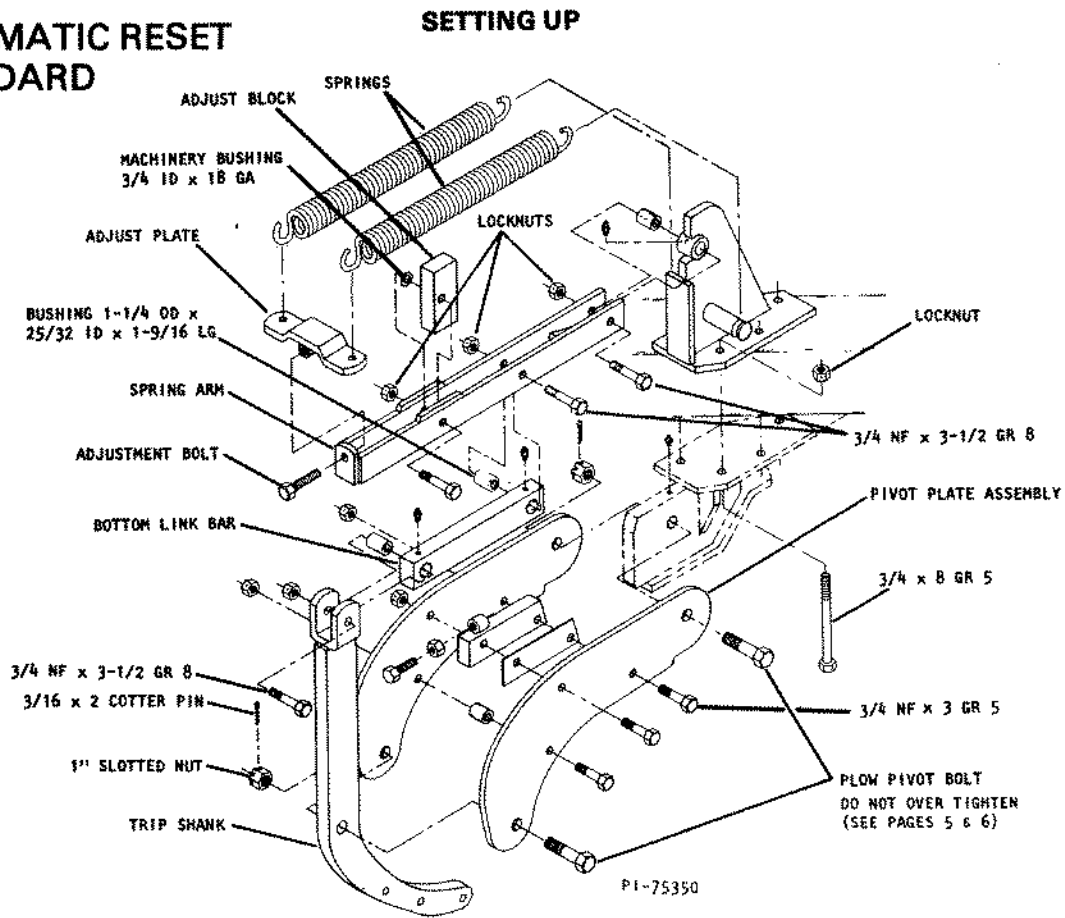

7. SHEAR BOLT STANDARD

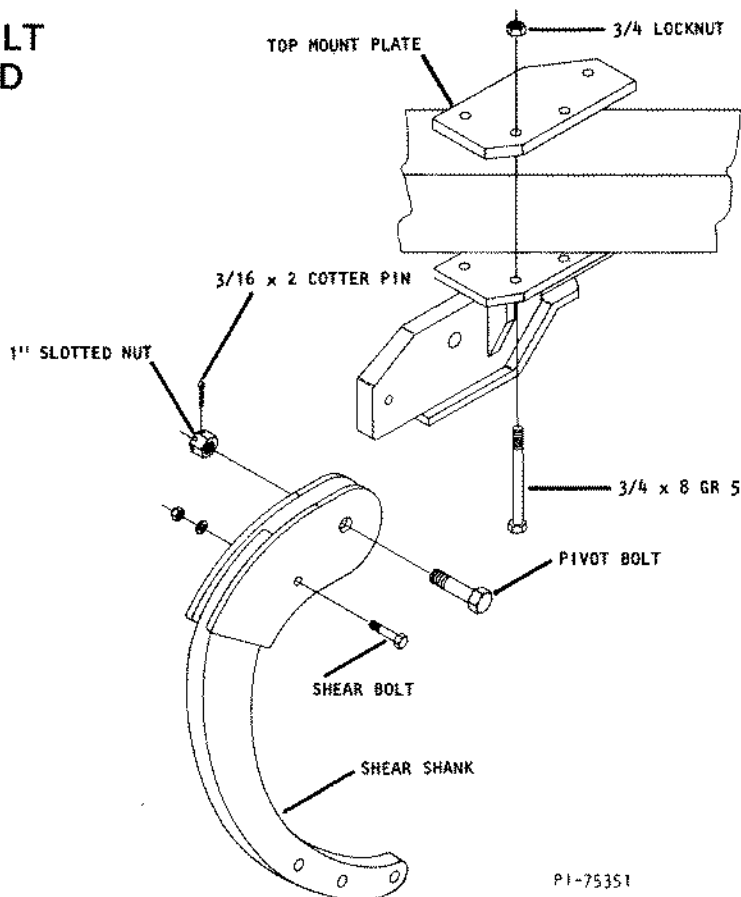

SETTING UP

8. HYDRAULICS

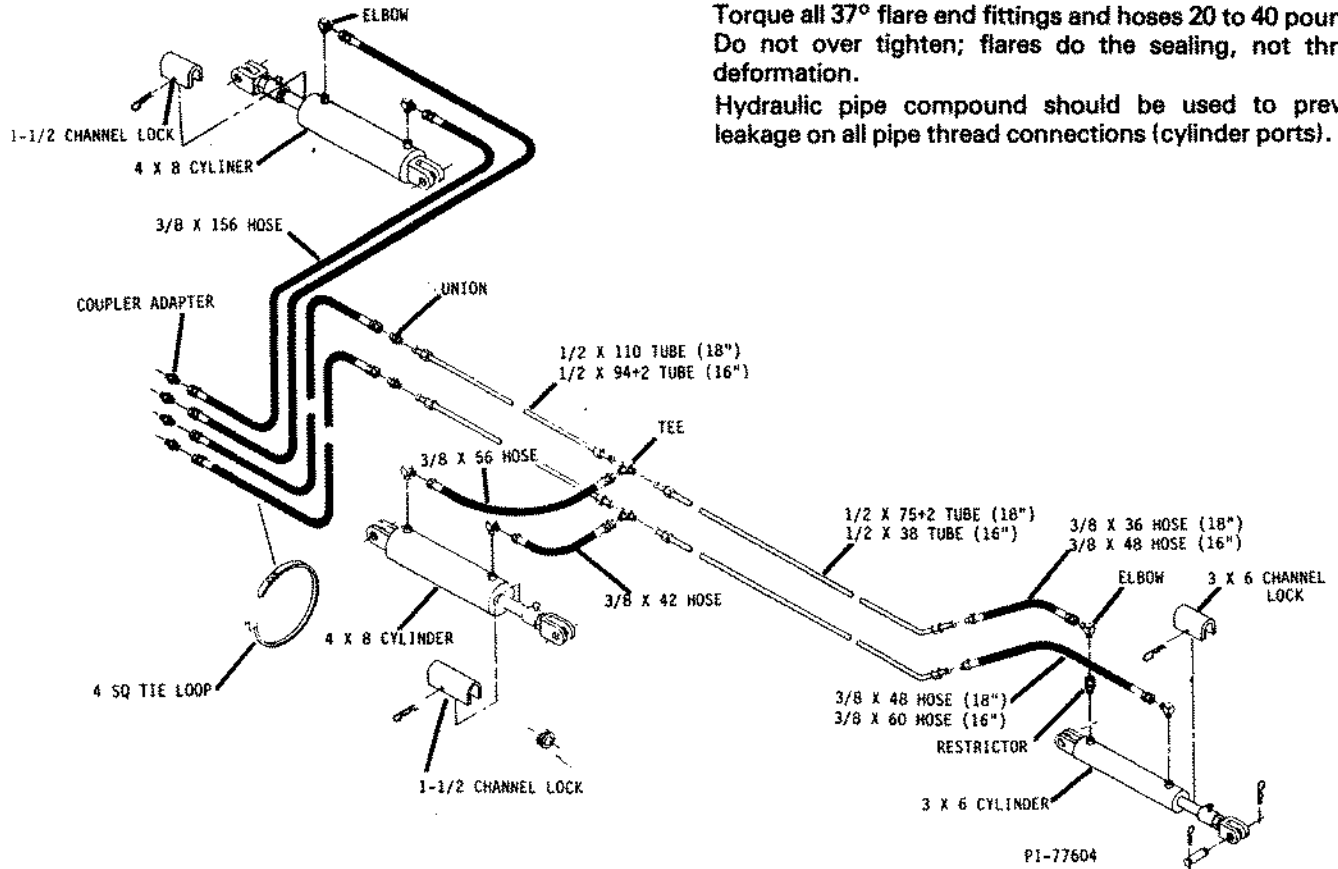

NOTE: HYDRAULIC FLUID ESCAPING UNDER PRESSURE CAN HAVE ENOUGH FORCE TO PENETRATE THE SKIN. INFECTION OR REACTION CAN RESULT IF MEDICAL TREATMENT IS NOT GIVEN IMMEDIATELY. MAKE SURE ALL CONNECTIONS ARE TIGHT AND THAT HOSES AND LINES ARE IN GOOD CONDITION BEFORE APPLYING PRESSURE TO THE SYSTEM. RELIEVE ALL PRESSURE BEFORE DISCONNECTING THE LINES OR PERFORMING OTHER WORK ON THE HYDRAULIC SYSTEM. TO FIND A LEAK UNDER PRESSURE USE A SMALL PIECE OF CARDBOARD OR WOOD. NEVER USE HANDS.

NOTE: THE TRACTOR HYDRAULIC SYSTEM MUST BE ABLE TO WORK AT 2,000 PSI MINIMUM TO OPERATE THIS PLOW.

9. BOTTOMS AND COULTERS

GENERAL PURPOSE I BOTTOM WITH OPTIONAL TRASHBOARD

General purpose bottom assemblies should be loosely bolted with the two lower mounting bolts. Then bolt the moldboard brace to the moldboard using the outer hole in the brace. If the brace does not fit properly with the standard, remount the brace to the moldboard using the inner hole on the brace (as shown) and shim the space between the brace and standard with 5/8 flat washers. Torque standard bolts to 200 ft/lbs.

NOTE: THE BRACE MUST BE CAREFULLY SHIMMED WITH THE PROPER NUMBER OF WASHERS. THERE SHOULD BE NO PUSHING OR PULLING ON THE MOLDBOARD WHEN THE BOLTS ARE TIGHTENED.

When mounting the brace with a trashboard bracket, mount to the inner hole on the brace and if necessary shim any space between the trashboard bracket and brace with 5/8 flat washers. Torque standard bolts to 200 ft/lbs.

The adjustable pitch feature is provided on all general purpose plow bottoms to aid penetration with worn shares, and thus prolong share life. This feature also provides more suck when additional penetration is required.

Caution must be used to insure the proper use of this feature. When new shares are in use the bottom should be set in the normal position.

Never allow the shin, share, or landside to wear until the frog is exposed. These parts should be checked periodically (more often when plowing in abrasive soil) and adjusted or replaced if worn. Plowing with worn, bent, or broken shares is economically poor, and it can result in a hard running plow and/or increased fuel costs.

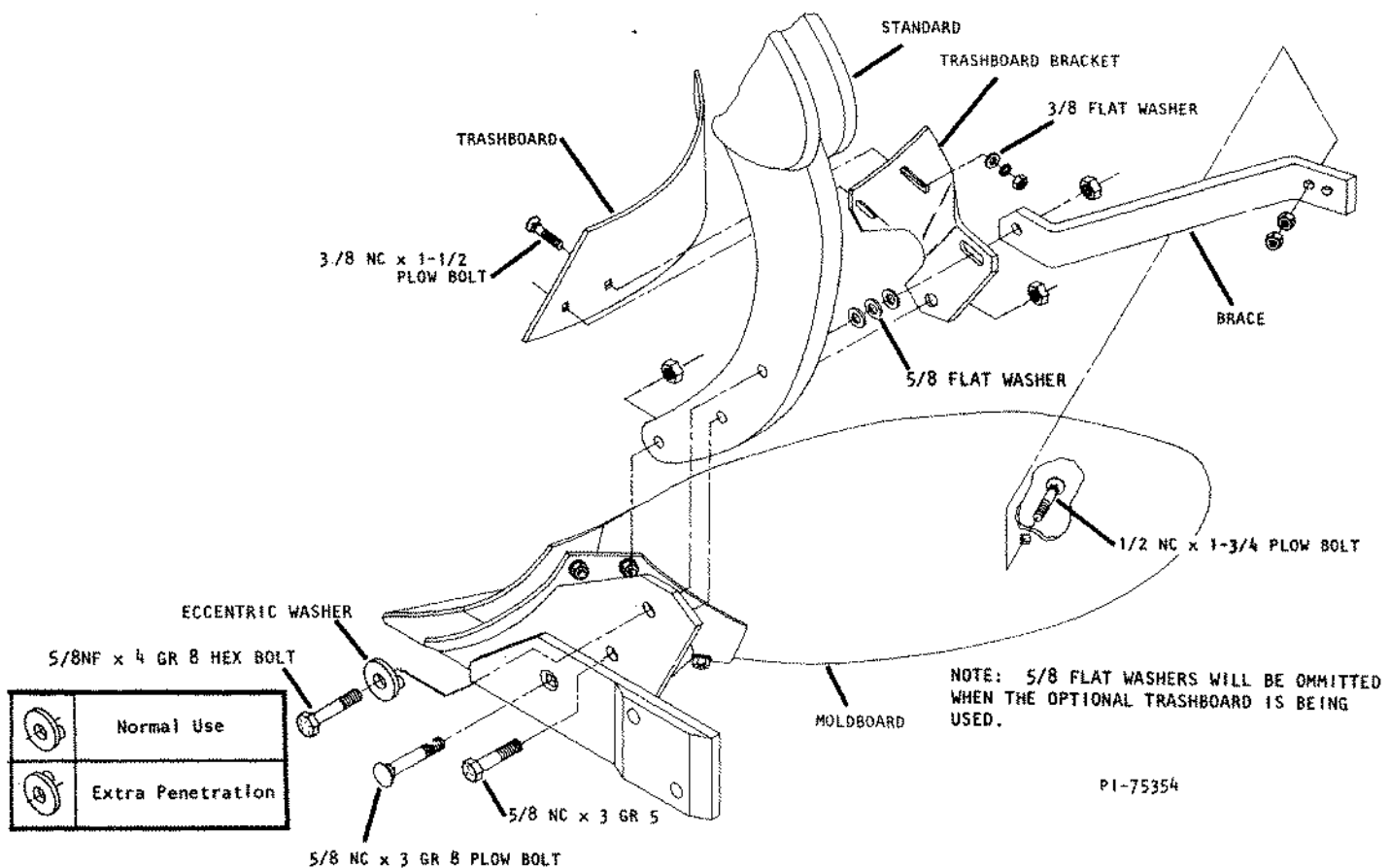

OPTIONAL EQUIPMENT

GENERAL PURPOSE II BOTTOM WITH OPTIONAL TRASHBOARD (PLASTIC TRASHBOARD SHOWN)

Bolt the bottoms to the standards. Torque to 200 foot pounds.

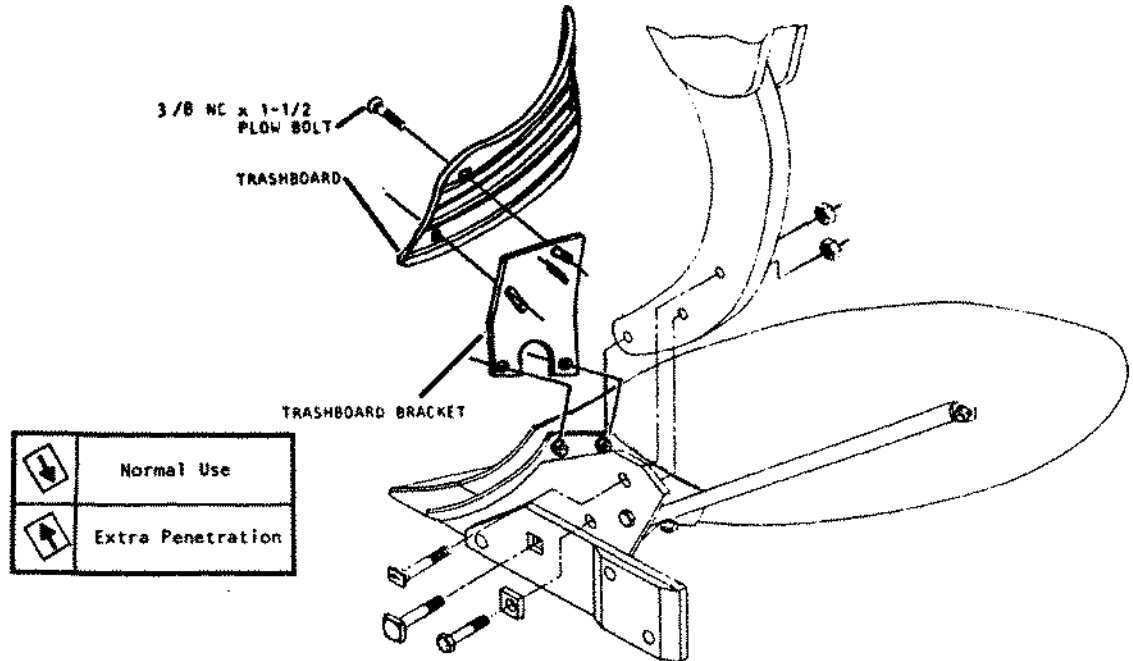

OPTIONAL EQUIPMENT

DEEP TILLAGE BOTTOM WITH OPTIONAL TRASHBOARD

Bolt the deep tillage and high speed bottoms to the standards and torque to 200 ft./lbs.

COULTERS

Refer to coulters operation and adjusting for coulters mounting.

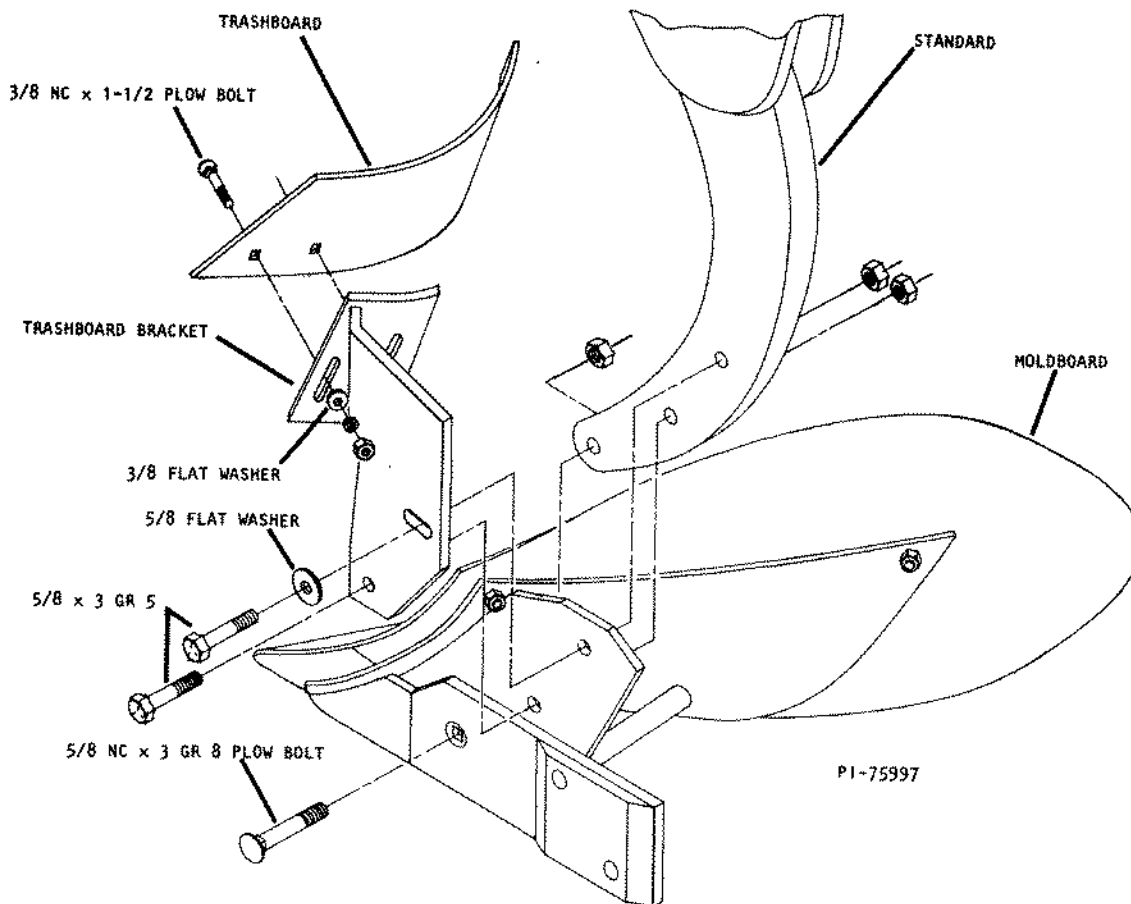

1 BOTTOM EXTENSION

NOTE: TO ASSURE PROPER ALIGNMENT OF BOTTOM(S) WHEN MOUNTING AN EXTENSION, THERE SHOULD BE A SLIGHT CLOCKWISE TWISTING LOAD PLACED ON THE MAIN FRAME TO EXTENSION JOINT BEFORE TIGHTENING BOLTS. THIS CAN BE ACCOMPLISHED BY HANGING THE TAILWHEEL SECTION ON THE END OF THE EXTENSION AND ALLOWING THE WEIGHT OF THE TAILWHEEL TO APPLY A CLOCKWISE (AS VIEWED FROM THE REAR) TWISTING LOAD TO THE FRONT JOINT OF THE EXTENSION.

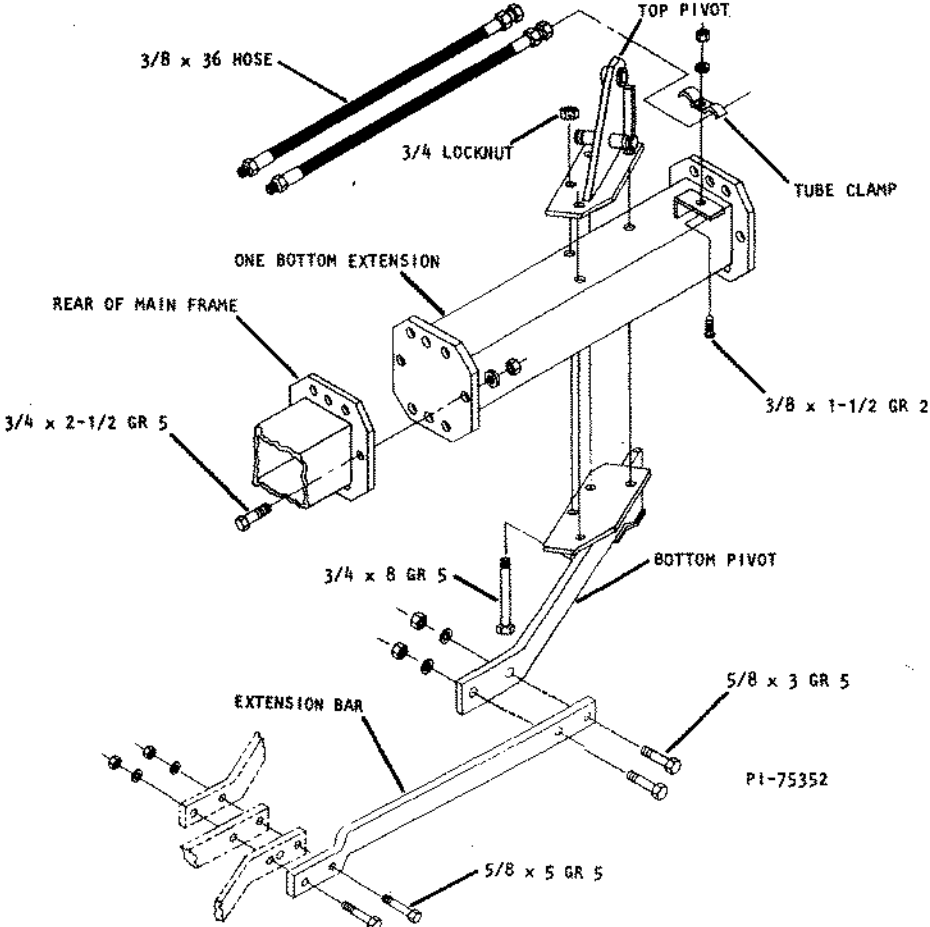

2 BOTTOM EXTENSION

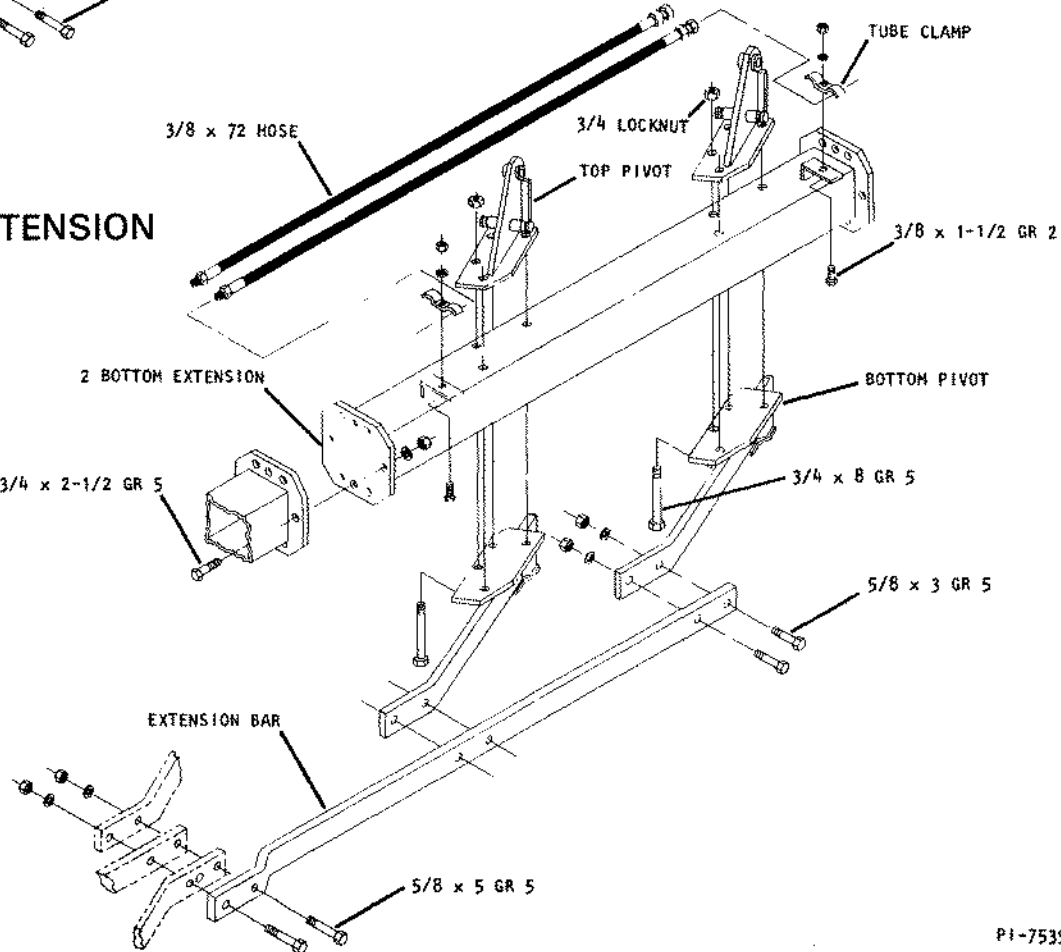

LUBRICATION

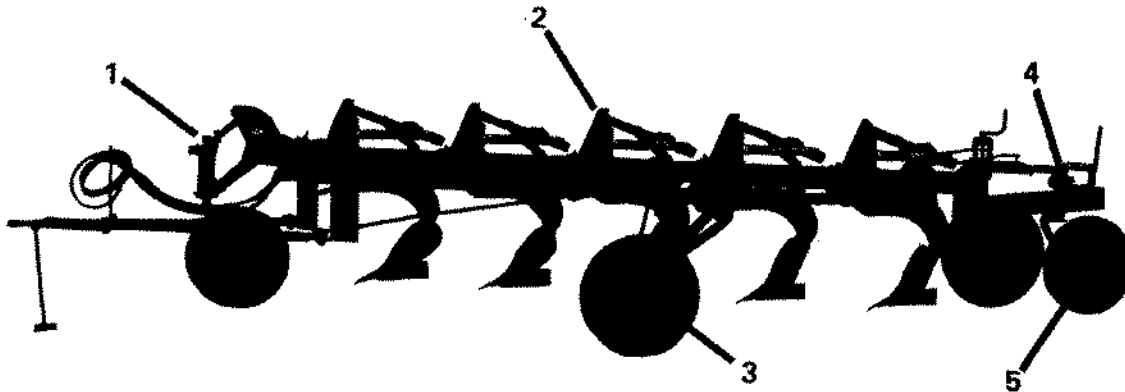

PI-75461

Grease fittings are provided at all points indicated in the lubrication chart. All parts provided with grease fittings should be lubricated with SAE Multi-purpose type grease.

If any grease fittings are missing, replace them immediately. Clean the fittings thoroughly before using grease gun.

Listed below are the lubrication procedures that should be carried out.

- | | | |
|--|-------|---|
| 1. Front Furrow Wheel
(Seven Fittings) | | Daily or Every
8 Hrs. |
| 2. Automatic Reset Standards
(Four Fittings) | | Daily or Every
8 Hrs. |
| 3. Landwheel
(Two Fittings) | | Daily or Every
8 Hrs. |
| 4. Tailwheel
(Two Fittings) | | Daily or Every
8 Hrs. |
| 5. Wheel Bearings | | Once a season disassemble,
clean and repack with good
quality wheel bearing grease. |
| 6. Coulters
(One Fitting Compression Coulters Only) | | Daily or Every
8 Hrs. |

TROUBLESHOOTING

PROBLEM	CORRECTIONS	PAGE
<p><u>SLOW GROUND ENTRY</u></p> <p>Entire Plow Penetrates Slowly</p>	<p>-Lower Land Wheel</p> <p>-Deep Suck Shares</p> <p>-Adjust Coulters</p> <p>-Worn Shares (Replace)</p>	<p>4</p> <p>7</p> <p>7</p> <p>—</p>
<p><u>RIDGING</u></p> <p>Ridging</p>	<p>-Level Frame</p> <p>-Raise or Lower Landwheel</p> <p>-Poor Soil Conditions and Soil Compaction from Tires</p>	<p>4</p> <p>4</p> <p>—</p>
<p><u>PLOW RUNNING CROOKED</u></p> <p>Plow Pulls into Unplowed Ground</p>	<p>-Adjust Hitch Closer to Furrow</p> <p>-Lower Land Wheel</p> <p>-Check Frame Level</p> <p>-Worn Wear Pads (Replace)</p>	<p>2</p> <p>3</p> <p>3</p> <p>—</p>
<p>Plow Pulls into Plowed Ground</p>	<p>-Adjust Hitch Away from Furrow</p> <p>-Check Frame Level</p>	<p>2</p> <p>3</p>
<p><u>RAGGED FURROW WALL</u></p> <p>Tailwheel Climbs Furrow Wall</p>	<p>- Need longer landsides</p> <p>-Increase Distance Between Coulter and Bottom</p> <p>-Adjust Tailwheel to Carry More Rear End Weight</p> <p>-Adjust Hitch</p> <p>-Tighten Stabilizer Spring</p>	<p>—</p> <p>7</p> <p>3</p> <p>2</p> <p>4</p>

TROUBLESHOOTING

PROBLEM	CORRECTIONS	PAGE
<u>UNEVEN SHARE WEAR</u>		
Excessive Heel Wear	-Lower Land Wheel	3
Excessive Point Wear	-Raise Land Wheel	3
<u>TRIP ASSEMBLIES</u>		
Floats too Easily	-Increase Spring Pressure	5
Excessive Tripping	-Change Stop Block Setting	5
Will not Reset	-Check Shares	—
	-Slow Down	—
<u>TRANSPORTING</u>		
Landwheel Slides	-Slow Down (See Safety Instructions)	—
	-Lock Tailwheel	2

WARRANTY

The only warranty Wil-Rich gives and the only warranty the dealer is authorized to give is as follows:

We warrant products sold by us to be in accordance with our published specifications or those specifications agreed to by us in writing at time of sale. Our obligation and liability under this warranty is expressly limited to repairing, or replacing, at our option, within 12 months after date of retail delivery, any product not meeting the specifications. ***We make no other warranty, express or implied and make no warranty of merchantability or of fitness for any particular purpose.*** Our obligation under this warranty shall not include any transportation charges or costs or installation or any liability for direct, indirect or consequential damage or delay. If requested by us, products or parts for which a warranty claim is made are to be returned transportation prepaid to our factory. Any improper use, operation beyond rated capacity, substitution of parts not approved by us, or any alteration or repair by others in such manner as in our judgement affects the product materially and adversely shall void this warranty. ***No employee or representative is authorized to change this warranty in any way or grant any other warranty.***

Wil-Rich reserves the right to make improvement changes on any of our products without notice.

When warranty limited or not applicable: Warranty on hoses, cylinders, hubs, spindles, engines, valves, pumps or other trade accessories are limited to the warranties made by the respective manufacturers of these components. Rubber tires and tubes are warranted directly by the respective tire manufacturer only, and not by Wil-Rich.

Warranty does not apply to any machine or part which has been repaired or altered in any way so as in our judgement to affect its reliability, or which has been subject to misuse, negligence or accident.

A Warranty Validation and Delivery Report form must be filled out and received by Wil-Rich to initiate the warranty coverage.

WARRANTY CLAIMS PROCEDURE

1. The warranty form must be returned to Wil-Rich within fifteen (15) working days from the repair date.
2. Parts returned to Wil-Rich without authorization will be refused. The parts must be retained at the dealership for ninety (90) days after the claim has been filed. If the Service Department would like to inspect the parts, a packing slip will be mailed to the dealer. The packing slip must be returned with the parts. The parts must be returned prepaid within thirty (30) days of receiving authorization. After the parts are inspected and warranty is verified, credit for the return freight will be issued to the dealer.
3. Parts that will be scrapped at the dealership will be inspected by a Wil-Rich Sales Representative, District Sales Manager or Service Representative within the ninety (90) day retaining period.

