

OPERATOR'S MANUAL

3PT SEEDBED FINISHER

PERSONAL SAFETY IS IMPORTANT!

ALL PERSONNEL INVOLVED WITH THE ASSEMBLY AND/OR OPERATION OF THIS EQUIPMENT MUST BE INFORMED OF PROPER SAFETY PROCEDURES. OPERATOR'S AND ASSEMBLY MANUALS PROVIDE THE NECESSARY INFORMATION. IF THE MANUAL IS LOST FOR A PARTICULAR IMPLEMENT, ORDER A REPLACEMENT AT ONCE. OPERATOR'S AND ASSEMBLY MANUALS ARE AVAILABLE AT NO CHARGE UPON REQUEST.

ADDRESS INQUIRIES TO:

WIL-RICH

PO BOX 1030

WAHPETON, ND 58074

PH (701)642-2621 FAX (701)642-3372



TO THE OWNER

The Wil-Rich 3PT SBF has a standard equipment a clearance lighting package . If your 3PT SBF is not equipped with this package, it can be ordered by contacting your local dealer or the factory directly.

It is the responsibility of the user to read the Operator's Manual and comply with the safe and correct operating procedures as pertains to the operation, lubrication and maintenance of the product according to the information outlined in the Operator's Manual.

If this machine is used by an employee or is loaned or rented, make certain that the operator(s), prior to operating, is instructed in safe and proper use and reviews and understands the Operator's Manual.

The user is responsible for inspecting his/her machine and for having parts repaired or replaced when continued use of this product would cause damage or excessive wear to the other parts. The word NOTE is used to convey information that is out of context with the manual text; special information such as specifications, techniques, reference information of supplementary nature.

 <small>A DIVISION OF TIC UNITED CORP.</small>	
Serial Number: <input type="text"/>	
<small>This machine may be covered by one or more of the following patents: -PAT. U.S. - 3,606,928 3,782,481 4,451,052 4,296,695 4,054,177 4,068,723 4,121,852 -PAT. CAN. - 1974 1976 1982 1985 -OTHER PATENTS PENDING</small>	<small>Wahpeton, ND 58074</small>
WIL-RICH NOBLE	
Made in USA	

When in need of parts, always specify the model and serial number. Write this number in the space provided. The serial number plate is located on the main frame in the front right corner of 3PT SBF models.

CONTENTS

Introduction	1-2
Safety	2-3
Preparation	3-4
Mast Assembly	5
Tool Bar Adjustment	6
Wing Adjustments	6-7
Spike Harrow	7
Leveling Board	8
Rolling Basket	9
Rigid Gauge Wheel	9
Maintenance & Storage	10
Trouble Shooting	11

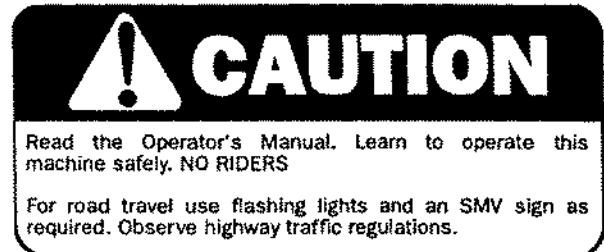

MODIFICATIONS

It is the policy of Wil-Rich to improve its products whenever possible and practical to do so. We reserve the right to make changes, improvements and modifications at any time without incurring obligation to make such changes, improvements on any equipment sold previously.

INTRODUCTION

SEEDBED FINISHER FEATURES

Rugged frame with channel and tubular steel members gives the strength needed to work behind big tractors at high speeds.

Choice of sizes: 6-row hydraulically folding-wing type, 19ft. 3in.; 8-row hydraulically folding-wing type, 25ft. 10in.

Folding-wing models; are equipped with hydraulic cylinders as standard. The wings may be locked rigid for leveling or may be allowed to float for better work in rolling field conditions.

Spiral 5-bar reels; with blades of high quality plowshares steel for exceptional reliability, chop stalks and clods and thoroughly mix residue and soil.

Reel bearings; are cartridge-type, regreasable, triplesealed, self-aligning ball bearings (two per reel). Reel bearings are equipped with wear guards and grease fitting guards.

Heavy-duty spike-tooth center sections; have five ranks of teeth that further pulverize and loosen soil. Chain suspension linkage keeps working depth constant across the entire width of cut - even in rough terrain.

Rolling baskets; are ideal for uniform chemical incorporation. They stir and firm the soil and provide a ready-to-plant surface.

Metal levelling boards; are mounted on leaf springs and are reversible for longer life.

GENERAL

The 3PT Seedbed Finisher is a 6-row and 8-row are folding-wing type machines.

Working widths 19ft 3in (6-row) and 25ft. 10in (8-row) are available.

Tractor horsepower requirements is 30-40 hp for each 2-row unit with recommended operating speed at 4-6 mph.



CAUTION! CARE MUST BE EXERCISED WHEN HITCHING THE SEEDBED FINISHER TO THE TRACTOR TO PREVENT INJURY TO THE HANDS OR FINGERS.

FRAME AND REELS

Check and tighten all frame bolts securely after the first day of operation.

ASSEMBLY INFORMATION

Remove all wires and arrange the parts conveniently.

NOTE: ALWAYS WEAR SAFETY GLASSES OR GOGGLES AND BE CAREFULL WHEN CUTTING WIRES AND STEEL BANDS AS THEY ARE UNDER TENSION AND WILL SPRING BACK WHEN CUT.

Whenever the terms "Left" and "Right" are used, it should be understood to mean from a position behind and facing the machine.

Lubricate all bearings and moving parts as you proceed and make sure they work freely.

Loosely install all bolts connecting mating parts before final tightening.

Do not attempt to remove any obstruction while the machine is in motion.

Use extreme care when operating close to ditches, fences, or on hillsides.

No one other than the operator should ride on the tractor.



THIS SYMBOL IS USED TO CALL YOUR ATTENTION TO INSTRUCTIONS CONCERNING YOUR PERSONAL SAFETY. BE SURE TO OBSERVE AND FOLLOW THESE INSTRUCTIONS.

CI-77637

SAFETY

Safety decals appear at various locations on your machine. These decals are provided for your safety and must be kept clean. Replace any decal that becomes worn, damaged, painted over, or otherwise difficult to read. Replacement decals are available through your dealer.

BEFORE OPERATING

Use extreme care when making adjustments.

When working under or around the machine always lower shanks to the ground.

After servicing, be sure all tools, parts, or servicing equipment is removed from the machine.

Before and during operation be sure no one is on or around the implement. Serious injury can result from improper use.

Reduce speed when cornering on field ends and when operating on or across dead furrows.

HYDRAULICS

Inspect all hydraulic hoses and fittings for cracks and abrasions at least once a year. Tighten or replace as needed.

When connecting the hoses to the cylinders, tubing, or fittings; always use one wrench to prevent the hose from twisting and another wrench to tighten the union. Excessive twisting will shorten the hose life.

Do not over-tighten hydraulic fittings, excessive torque may cause them to crack.

Care must be taken to prevent twisting when tightening hose connections. Straighten any hose that appears twisted immediately. A twisted hose can burst under pressure.

Hydraulic fluid escaping under pressure can have enough force to penetrate the skin. Hydraulic fluid may also infect a minor cut or opening in the skin. If injured by escaping fluid, see a doctor at once. Serious infection or reaction can result if medical treatment is not given immediately. Make sure all connections are tight and that hoses and lines are in good condition before applying pressure to the system. To find a leak under pressure use a small



WARNING

Before unhitching the implement from the tractor, lower the implement to the ground and relieve all hydraulic pressure.

PREPARATION

ON-HIGHWAY OPERATION

Always place the machine in the transport position.

Comply with your state and local laws governing highway safety when moving machinery on a highway.

Reduce road speed on corners.

Drive at a reasonable speed to maintain complete control of the machine at all times.

A S.M.V. emblem must be used at all times while traveling on public roads.

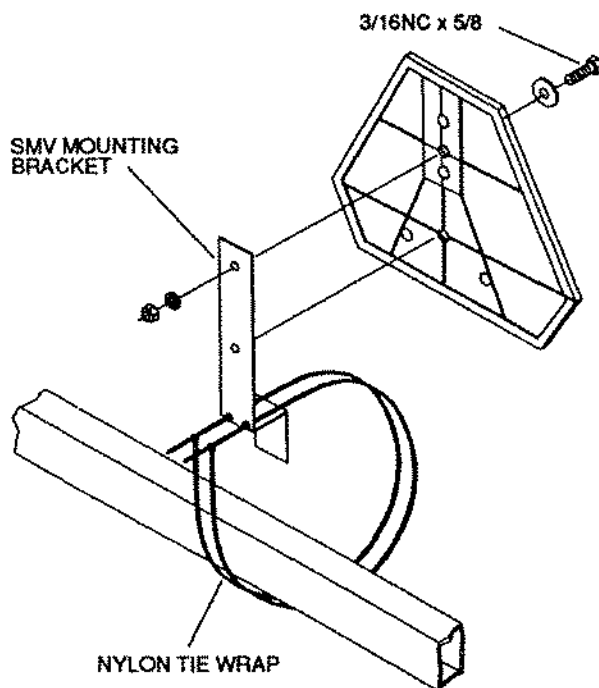

CI-77643

The SMV emblem is to be secured as near to the rear and centered, or as near to the left of center of the implement as practicable.

The emblem is to be 2 to 6ft above the ground measured from the lower edge of the emblem.

Before using the 3PT Seedbed Finisher a careful inspection must become routine. A check must be made to insure that all hardware is securely tightened and moving parts properly lubricated.

Tighten all loose nuts and bolts and replace any bent or broken parts.

When tightening bolts, they must be torqued to the proper number of foot-pounds as indicated in the table, unless specified. It is important that all bolts be kept tight.

On new machines, all nuts and bolts must be rechecked after a few hours of operation.



TORQUE IN FOOT POUNDS

BOLT DIA	3/8	1/2	5/8	3/4	7/8	1
HEX HEAD	9/16	3/4	15/16	1-1/8	1-5/16	1-1/2
UNC GRADE	2	18	45	89	160	252
	5	30	68	140	240	360
	8	40	100	196	340	528
UNF GRADE	2	21	51	102	178	272
	5	32	70	168	264	392
	8	48	112	216	368	544

CI-75623

When replacing a bolt, use only a bolt of the same grade or higher.

Bolts with no markings are grade 2.

Grade 5 bolts furnished with the machine are identified by three radial lines on the head.

Grade 8 bolts furnished with the machine are identified by six radial lines on the head.

All U-bolts are grade 5.

TIRE INFLATION

The use of the proper air pressure is the most important factor in satisfactory performance and maintenance of implement tires. Underinflation will damage the cord body of the tire and cause a series of diagonal breaks in the fabric in the sidewall area.

If the tire buckles or wrinkles, the air pressure must be increased to the point where the sidewalls remain smooth while operating.

Check the air pressure every two or three weeks and do not allow pressure to drop to a point where buckling or wrinkling of the tire may be possible.

NOTE: DO NOT OVERINFLATE TIRES.

WHEEL BOLTS

It is recommended that all wheel bolts be checked for tightness before using and again after one day of use. Paint or rust can work out causing the wheel to become loose. Check periodically to be sure the wheel bolts are tight.

HYDRAULICS

Check wing folding cylinders for proper alignment and operation. On new machines check that the hydraulic system has been properly charged and purged.

LUBRICATION

Make sure the seedbed finisher is properly lubricated. See maintenance, page 10.

BEARING ASSEMBLIES

IMPORTANT - The spindle nut on all hub and spindle assemblies is preset at the factory. Road transport and field working will seat the bearings and may require additional adjustment. After 20 hours of machine operation remove the dust cap and check the bearing tightness of all hub and spindles. Remove the cotter pin and rotate the tire while tightening the spindle nut. Tighten until the drag in the tire assembly stops the tire rotation. Locate the cotter pin hole in the spindle and loosen the spindle nut enough to allow insertion of the cotter pin. Replace cotter pin and dust cap.

TRACTOR PREPARATION

Refer to the operator's manual furnished with your tractor for recommended adjustments and weight distribution.

NOTE: CHECK YOUR TRACTOR'S HYDRAULIC FLUID LEVEL AFTER CYCLING HYDRAULICS AND FILLING NEW CYLINDERS AND LINES. REFILL IF NECESSARY.

TRANSPORTING

NOTE: BEFORE RAISING OR LOWERING WINGS, BE SURE WING LOCK PINS HAVE BEEN REMOVED AND PROPERLY STORED. (See Fig. 1)

NOTE: USE EXTREME CAUTION WHEN WORKING AROUND OVERHEAD POWER TRANSMISSION LINES.

NOTE: SET TRACTOR THROTTLE TO IDLE WHEN UNFOLDING WINGS.



WING IN TRANSPORT POSITION

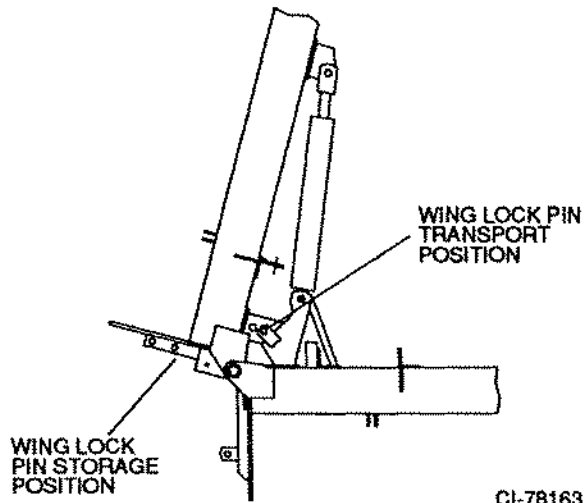
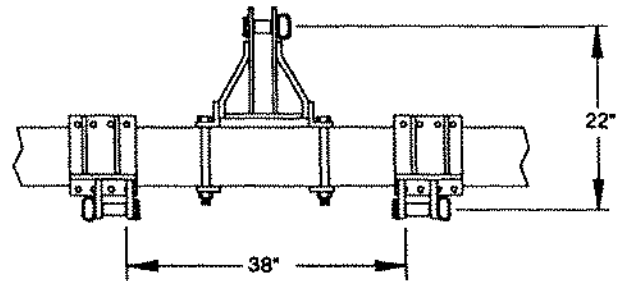

FIG. 1

3PT HITCH CATEGORY III



CI-78162

Fig. 2

MAST ASSEMBLY

NOTE: FOR SAFETY AND EASE OF SETUP, IT IS RECOMMENDED THAT THE TOOL BAR BE ATTACHED TO A TRACTOR AFTER THE HITCH POINTS HAVE BEEN SECURED. DO NOT DEPEND ON YOUR TRACTOR'S HYDRAULIC SYSTEM AS THE SOLE SUPPORT OF THE BAR.

Attach the masts to the tool bar center approximately as shown. Attach the lower hitch points to the tool bar as shown below for your particular 3PT hitch. (See Fig.'s 2, 3 & 4)

3PT QUICK HITCH CAT. II

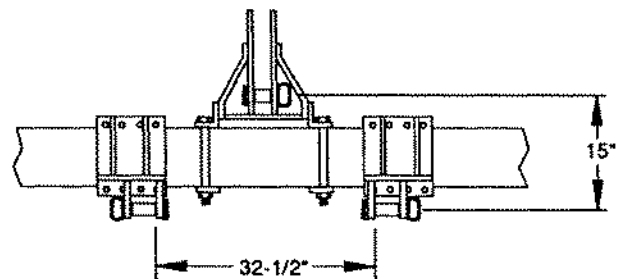

CI-78162B

Fig. 3

3PT QUICK HITCH CAT. III

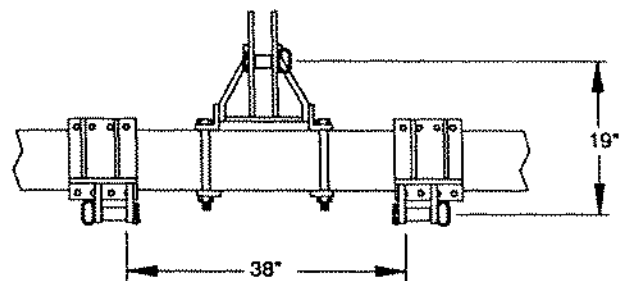

CI-78162A

Fig. 4

TOOL BAR ADJUSTMENT

LEVELING MAIN FRAME

Front to rear leveling of 3PT hitch models is done with the tractor's control arms. Consult your tractor's operators manual for specific information.

If the Seedbed Finisher is not level from side to side adjust the bottom link on the tractor. Refer to the tractor operator's manual for additional information on hitch settings.

The bottom 3PT links can be allowed to swing when the unit is operating, however, there should be no lateral movement of the bottom links when the unit is raised for transport.

WING ADJUSTMENTS

WING DEPTH

The operational depth of the wing is controlled by the main frame setting.

WING LEVELING

The wings are leveled to the main frame using the shims provided. Shims are required in both the main and rear bar hinges (See Figs. 5 & 6). Use the shims as needed.

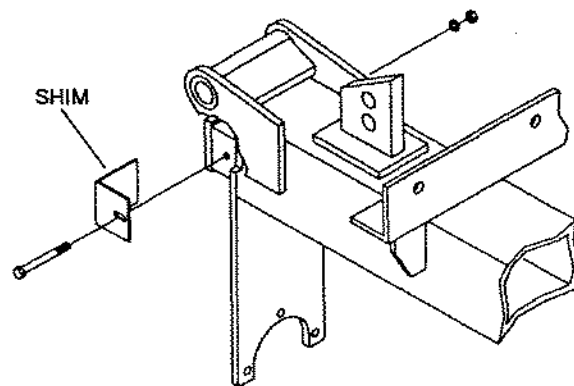

Fig. 5 Wing Frame Hinge

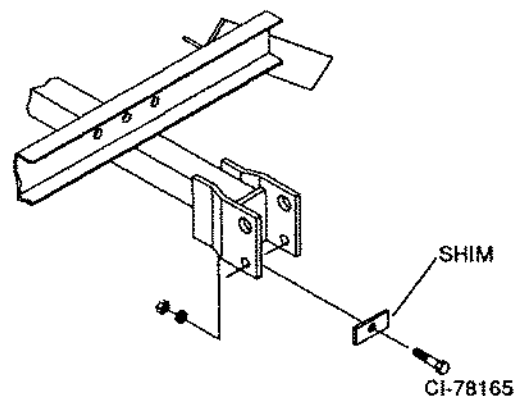

Fig. 6 Rear Bar Hinge

WINGS IN WORKING POSITION

The wings can be locked in the level position or they can be allowed to float up, by putting the lock down pins in the storage holes, and the tractor hydraulics in a float mode.

There are lock down pins in both the rear bar and main frame hinges. Be sure both are in the desired position. (See Fig. 7 & 8.)

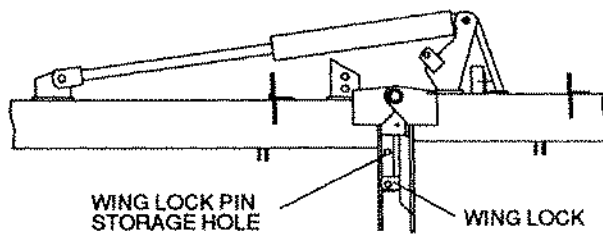

Fig. 7 Main Frame

CI-78164

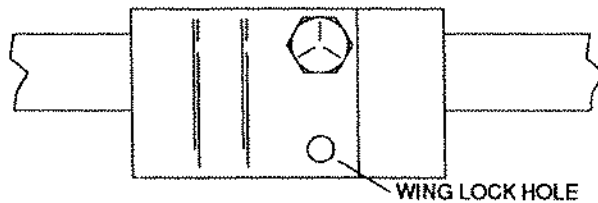

Fig. 8 Rear Bar

CI-77073

When folding the wings, be sure to remove both front and rear lock down pins.

WARNING

TO AVOID INJURY FROM FALLING WINGS

Keep everyone clear of machine when folding or unfolding wings.

Before servicing or transporting, lock the wings with lock pins.

Before removing wing lift cylinders lower wings to the field use position.

TO AVOID INJURY FROM MACHINE FALLING

Before transporting or servicing lock wheel frame in raised position with channel lock and pin.

SPIKE TOOTH HARROW

Adjust all the chains equally. On hanger chains for spike-tooth sections, leave one or more links of slack to allow the harrow to flex. The spike-tooth height is adjustable to compensate for wear.

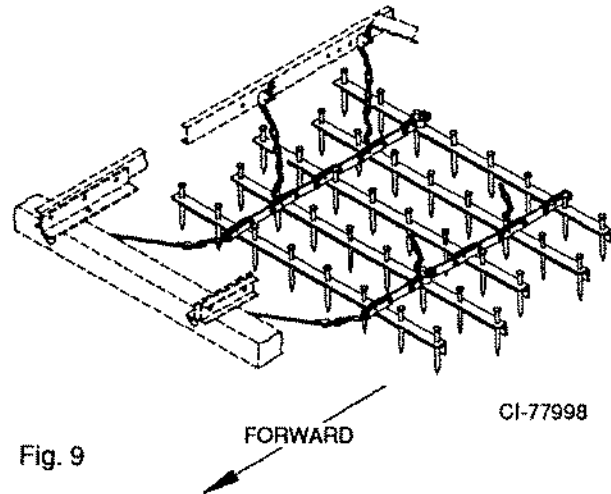

LEVELING BOARD

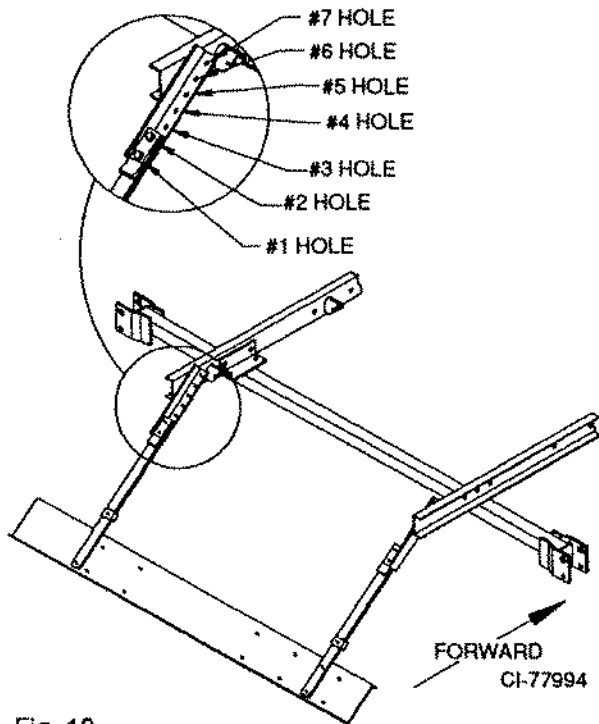

Fig. 10

#1 & #2 holes are the recommended starting position. This position will put the leveling boards at there lowest level. Adjustment may need to be made for specific seed bed preparation. See fig. 10.

Keep the frame as level as possible.

The leveling boards are reversible for longer life.

ROLLING BASKET

Down pressure on the baskets can be adjusted by using any of the adjustments at "A", "B" or "C". See fig. 11.

The adjustments at "A" are used to change the down pressure on the baskets by changing the amount of the compression on the spring.

Adjustments "B" and "C" also affect down pressure by changing the position of the arm relative to the frame.

The front basket can be raised or lowered by loosening the attaching hardware between the arm and the pivot bracket and moving the jam nuts to the adjusting screw "D".

It is suggested that the front basket be positioned a little higher than the rear basket. Retighten attaching hardware to specified torque after the adjustment is made.

NOTE: SEE THE ASSEMBLY MANUAL FOR THE APPROXIMATE PLACEMENT OF THE ROLLING BASKETS.

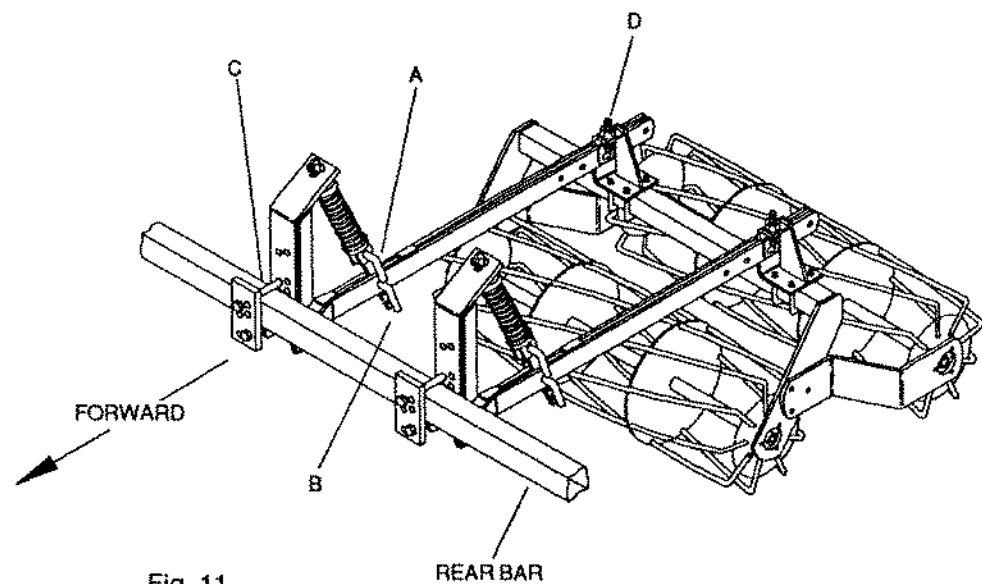

Fig. 11

CI-77980

RIGID GAUGE WHEEL

The rigid gauge wheel is mounted to the Seedbed Finisher wings only. It must be mounted outward as far as possible to give the wing its best floatation.

NOTE: THE GAUGE WHEEL MUST BE MOUNTED ON THE FRONT OF THE WING.

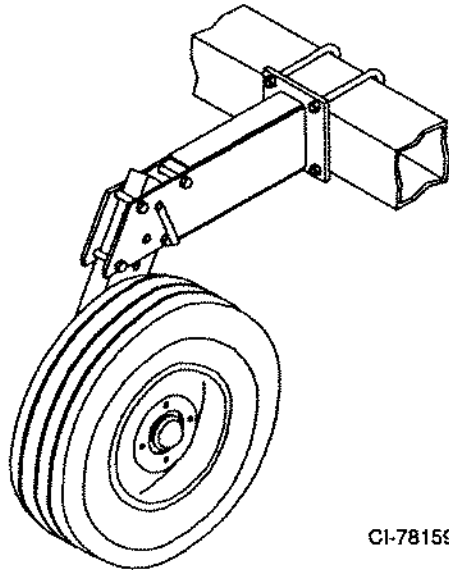

CI-78159A

Fig. 12

Be sure to operate this machine in a level position.

Be careful when turning so you do not side load the gauge wheels.

Adjust gauge wheel height by loosening 1/2x3-1/2" cap screw and sliding the wheel arm up or down as needed in the clamp.

The gauge wheel uses a 18x9.5-8 4-ply rated floatation type tire. Maintain tire inflation at 30 psi air pressure. Check pressure frequently.

MAINTENANCE

Periodic checks must be made to assure that all nuts and bolts remain securely tightened. Loose hardware is easily bent or lost and can cause excessive wear on parts. Replace any bent or broken bolts as soon as they are discovered.

Clean off any dirt or grease that may accumulate on moving parts at regular intervals. This will prevent any abrasive action which could cause excess or premature wear. Thoroughly inspect the implement for loose or broken parts and adjust or replace as necessary.

It is important that the implement be regularly lubricated as recommended to obtain the most efficient operation. Proper lubrication helps prevent down-time due to excessive wear and increases machine life.

HUB & SPINDLE ASSEMBLIES-GAUGE WHEEL

Each hub and spindle assembly comes with a grease fitting installed in the hub. These should be greased once a week during steady use. **CAUTION - DO NOT OVER GREASE!**

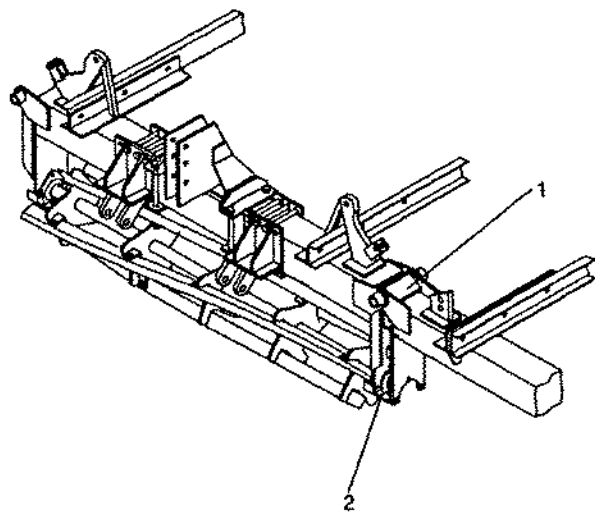

Fig. 13

CI-78166

1. HINGE

Each wing has one grease fitting which is greaseable only when the wing is UNFOLDED. These should be greased every 50 hours.

2. REEL BEARINGS

Each reel has 2 grease fittings protected by a grease fitting guard. These should be greased every 100 hours.

CYLINDER SHAFTS

If cylinder shafts are left exposed for any extended period of time, they must be coated with grease to protect them from rust and corrosion.

STORAGE

NOTE: IF POSSIBLE STORE YOUR SEEDBED FINISHER INSIDE.

At the end of a season, clean the implement thoroughly to remove any trash, soil or dirty grease which could hold moisture and cause premature rusting. Repaint any chipped, bare, or rusted areas to prevent any further deterioration. Inspect the machine for any worn or broken parts and adjust or replace as required.

See your dealer for any parts and/or service which may be needed.

Thoroughly lubricate all grease fittings at the end of the season's use and again before the first operation of the next season.

Avoid possible damage to the hydraulic system by lowering the machine onto the reels and relieve the pressure on the system.

TROUBLE SHOOTING

PROBLEM	POSSIBLE CAUSE	SOLUTION
Poor or uneven penetration.	Incorrect leveling adjustments on main frame or wings.	See leveling, page 6.
Settling of entire implement from raised position.	Leaking tractor hydraulic control valve.	See tractor manual.
Wings lowering too rapidly.	Incorrect cylinder installed, should have 1/16" dia. integral restrictor cylinder.	See Wing Lift Circuitry in assembly manual and install correct cylinder.
Machine will not pull straight, (skewing).	Seedbed Finisher not level.	See leveling page 6.

WARRANTY

The only warranty Wil-Rich gives and the only warranty the dealer is authorized to give is as follows:

We warrant products sold by us to be in accordance with our published specifications or those specifications agreed to by us in writing at time of sale. Our obligation and liability under this warranty is expressly limited to repairing, or replacing, at our option, within 12 months after date of retail delivery, any product not meeting the specifications. *We make no other warranty, express or implied and make no warranty of merchantability or of fitness for any particular purpose.* Our obligation under the warranty shall not include any transportation charges or costs or installation or any liability for direct, indirect or consequential damage or delay. If requested by us, products or parts for which a warranty claim is made are to be returned transportation prepaid to our factory. Any improper use, operation beyond rated capacity, substitution of parts not approved by us, or any alteration or repair by others in such manner as in our judgment affects the product materially and adversely shall void this warranty. *No employee or representative is authorized to change this warranty in any way or grant any other warranty.*

Wil-Rich reserves the right to make improvement changes on any of our products without notice.

When warranty limited or not applicable: Warranty on hoses, cylinders, hubs, spindles, engines, valves, pumps or other trade accessories are limited to the warranties made by the respective manufactures of these components. Rubber tires and tubes are warranted directly by the respective tire manufacturer only, and not by Wil-Rich.

Warranty does not apply to any machine or part which has been repaired or altered in any way so as in the our judgment to affect its reliability, or which has been subject to misuse, negligence or accident.

A Warranty Validation and Delivery Report Form must be filled out and received by Wil-Rich to initiate the warranty coverage.

WARRANTY CLAIMS PROCEDURE

1. The warranty form must be returned to Wil-Rich within fifteen (15) working days from the repair date.
2. Parts returned to Wil-Rich without authorization will be refused. The parts must be retained at the dealership for ninety (90) days after the claim has been filed. If the Service Department would like to inspect the parts, a packing slip will be mailed to the dealer. The packing slip must be returned with the parts. The parts must be returned prepaid within thirty (30) days of receiving authorization. After the parts are inspected and warranty is verified, credit for the return freight will be issued to the dealer.
3. Parts that will be scrapped at the dealership will be inspected by Wil-Rich Sales Representatives, District Sales Managers or Service Representatives within the ninety (90) day retaining period.

