



# ASSEMBLY INSTRUCTIONS



## 5 SECTION FIELD CULTIVATORS

 **WIL-RICH**

PO Box 1030  
Wahpeton, ND 58074  
PH (701) 642-2621  
Fax (701) 642-3372  
[www.wil-rich.com](http://www.wil-rich.com)

# WARRANTY

The only warranty Wil-Rich gives and the only warranty the dealer is authorized to give is as follows:

We warrant products sold by us to be in accordance with our published specifications or those specifications agreed to by us in writing at time of sale. Our obligation and liability under this warranty is expressly limited to repairing, or replacing, at our option, within 12 months after date of retail delivery, any product not meeting the specifications. **We make no other warranty, express or implied and make no warranty of merchantability or of fitness for any particular purpose.** Our obligation under the warranty shall not include any transportation charges or costs or installation or any liability for direct, indirect or consequential damage or delay. If requested by us, products or parts for which a warranty claim is made are to be returned transportation prepaid to our factory. Any improper use, operation beyond rated capacity, substitution of parts not approved by us, or any alteration or repair by others in such manner as in our judgment affects the product materially and adversely shall void this warranty. **No employee or representative is authorized to change this warranty in any way or grant any other warranty.**

Wil-Rich reserves the right to make improvement changes on any of our products without notice.

**When warranty limited or not applicable:** Warranty on hoses, cylinders, hubs, spindles, engines, valves, pumps or other trade accessories are limited to the warranties made by the respective manufactures of these components. Rubber tires and tubes are warranted directly by the respective tire manufacturer only, and not by Wil-Rich.

Warranty does not apply to any machine or part which has been repaired or altered in any way so as in the our judgment to affect its reliability, or which has been subject to misuse, negligence or accident.

**A Warranty Validation and Delivery Report Form must be filled out and received by Wil-Rich to initiate the warranty coverage.**

## WARRANTY CLAIMS PROCEDURE

1. The warranty form must be returned to Wil-Rich within fifteen (15) working days from the repair date.
2. Parts returned to Wil-Rich without authorization will be refused. The parts must be retained at the dealership for ninety (90) days after the claim has been filed. If the Service Department would like to inspect the parts, a packing slip will be mailed to the dealer. The packing slip must be returned with the parts. The parts must be returned prepaid within thirty (30) days of receiving authorization. After the parts are inspected and warranty is verified, credit for the return freight will be issued to the dealer.
3. Parts that will be scrapped at the dealership will be inspected by a Wil-Rich Sales Representative, District Sales Manager or Service Representative within the ninety (90) day retaining period.

# PERSONAL SAFETY IS IMPORTANT!

ALL PERSONNEL INVOLVED WITH THE ASSEMBLY AND/OR OPERATION OF THIS EQUIPMENT MUST BE INFORMED OF PROPER SAFETY PROCEDURES. OPERATOR'S/ ASSEMBLY MANUALS PROVIDE THE NECESSARY INFORMATION. IF THE MANUAL IS LOST FOR A PARTICULAR IMPLEMENT, ORDER A REPLACEMENT AT ONCE. OPERATOR'S AND ASSEMBLY MANUALS ARE AVAILABLE AT NO CHARGE UPON REQUEST.

This Safety Alert symbol means **ATTENTION! BECOME ALERT YOUR SAFETY IS INVOLVED!**

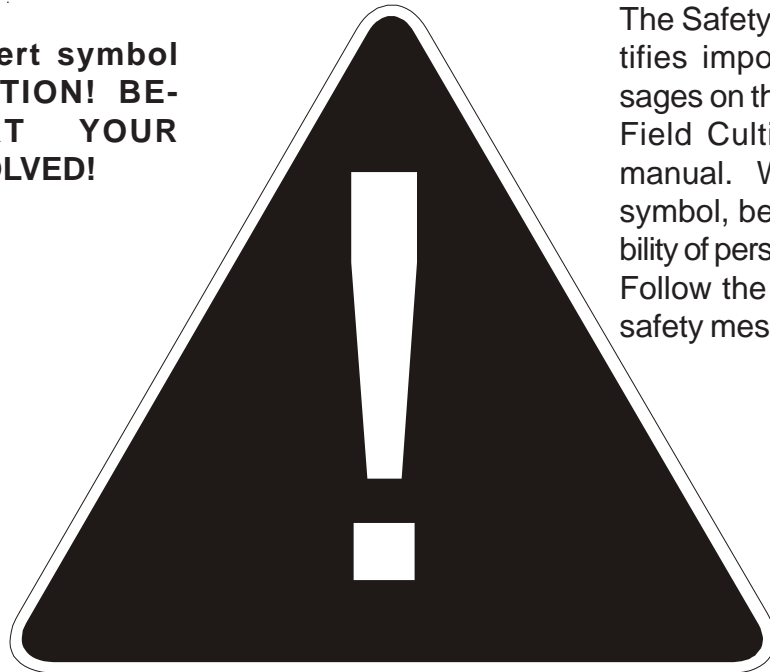

The Safety Alert symbol identifies important safety messages on the Wil-Rich Quad X Field Cultivator and in this manual. When you see this symbol, be alert to the possibility of personal injury or death. Follow the instructions in the safety message.

Why is SAFETY important to you?

## 3 Big Reasons

**Accidents Disable and Kill**  
**Accidents Cost**  
**Accidents Can Be Avoided**

### SIGNAL WORDS:

Note the use of the signal words **DANGER**, **WARNING** and **CAUTION** with the safety messages. The appropriate signal word for each message has been selected using the following guidelines:

### DANGER

An immediate and specific hazard which **WILL** result in severe personal injury or death if the proper precautions are not taken.

### WARNING

A specific hazard or unsafe practice which **COULD** result in severe personal injury or death if the proper precautions are not taken.

### CAUTION

Unsafe practices which **COULD** result in personal injury if proper practices are not taken, or as a reminder of good safety practices.

ADDRESS INQUIRIES TO: WIL-RICH PO BOX 1030  
WAHPETON, ND 58074  
PH (701) 642-2621 FAX (701) 642-3372

# CONTENTS

GENERAL INFORMATION .....	5
TRANSPORT SAFETY .....	6

## **ASSEMBLY**

OPENING BUNDLE .....	7-8
AXLES AND WALKING TANDEM .....	9
13' MAINFRAME .....	10
13' HITCH ASSEMBLY .....	11
HITCH ASSEMBLY CONTINUED .....	12
11'8" & 9'4" INNER WING .....	13
INNER WING HINGE .....	14
OUTER WING .....	15
OUTER WING HINGE .....	16
PARALLEL LINK GAUGE WHEEL .....	17
DEPTH GAUGE .....	18
SINGLE POINT DEPTH CONTROL .....	19
SINGLE POINT HANDLE .....	20
CHECK VALVE .....	21
HOSE CLAMP .....	22
<b>LIFT HYDRAULICS</b>	
XL <sup>2</sup> 46 .....	23
XL <sup>2</sup> 50 .....	24
XL <sup>2</sup> 55 .....	25
<b>WING FOLD HYDRAULICS</b>	
XL <sup>2</sup> 46 .....	26
XL <sup>2</sup> 50 & 55 .....	27
CHARGING LIFT SYSTEM .....	28
CHARGING WING FOLD SYSTEM .....	29
<b>SHANK PLACEMENTS</b>	
TWIN SPRING SHANK ASSEMBLY .....	30
SINGLE SPRING SHANK ASSEMBLY .....	31
13' MAINFRAME .....	32
11'8" WING .....	33
9'4" INNER WING .....	34
9'4" OUTER WING .....	35
7' OUTER WING .....	36
HD AUXILIARY HITCH .....	37
SAFETY DECAL PLACEMENT .....	38-39
LIGHTS .....	40

# ASSEMBLY INFORMATION

Remove all wires and arrange the parts conveniently.

NOTE: Always wear safety glasses or goggles and be careful when cutting wires and steel bands as they are under tension and will spring back when cut.

Wherever the terms "left" and "right" are used, it must be understood to mean from a position behind and facing the machine.

Lubricate all bearings and moving parts as you proceed and make sure they work freely.

Loosely install all bolts connecting mating parts before final tightening.

When tightening bolts, they must be torqued to the proper number of foot-pounds as indicated in the table unless specified. It is important that all bolts be kept tight.

On new machines, all nuts and bolts must be rechecked after a few hours of operation.

When replacing a bolt, use only a bolt of the same grade or higher. Except in shear bolt applications, where you must use the same grade bolt.

Bolts with no markings are grade 2

Grade 5 bolts furnished with the machine are identified by three radial lines on the head.

Grade 8 bolts furnished with the machine are identified by six radial lines on the head.

All U-bolts are grade 5.



THIS SYMBOL USED TO CALL YOUR ATTENTION TO INSTRUCTIONS CONCERNING YOUR PERSONAL SAFETY. BE SURE TO OBSERVE AND FOLLOW THESE INSTRUCTIONS

	GRADE 2			GRADE 5			GRADE 8		
TORQUE IN FOOT POUNDS									
BOLT DIA	3/8	1/2	5/8	3/4	7/8	1			
HEX HEAD	9/16	3/4	15/16	1-1/8	1-5/16	1-1/2			
UNC GR2	18	45	89	160	252	320			
UNC GR5	30	68	140	240	360	544			
UNC GR8	40	100	196	340	528	792			
UNF GR2	21	51	102	178	272	368			
UNF GR5	32	70	168	264	392	572			
UNF GR8	48	112	216	368	792	840			

**CAUTION**

TO AVOID INJURY AND/OR MACHINE DAMAGE:

- Refer to Operator's Manual for safety instructions.
- Do not stand or climb on machine when operating.
- Use clean hazard flashers and SMV sign when transporting.
- Observe highway traffic regulations.

23325

## MODIFICATIONS

It is the policy of Wil-Rich to improve its products whenever possible and practical to do so. We reserve the right to make changes, improvements and modifications at any time without incurring obligation to make such changes, improvements on any equipment sold previously.

**CAUTION**

FAILURE TO FOLLOW THESE INSTRUCTIONS MAY RESULT IN PERSONAL INJURY AND/OR EQUIPMENT DAMAGE.

- Just before and during operation be sure no one is on or around the implement.

- Before activating the hydraulic system, check hoses for proper connections.

- Before lowering the wings for the first time, make sure the entire system has been charged with oil.

- With wings down always install hydraulic cylinder channel lock(s) for transporting.

53334

# SAFETY

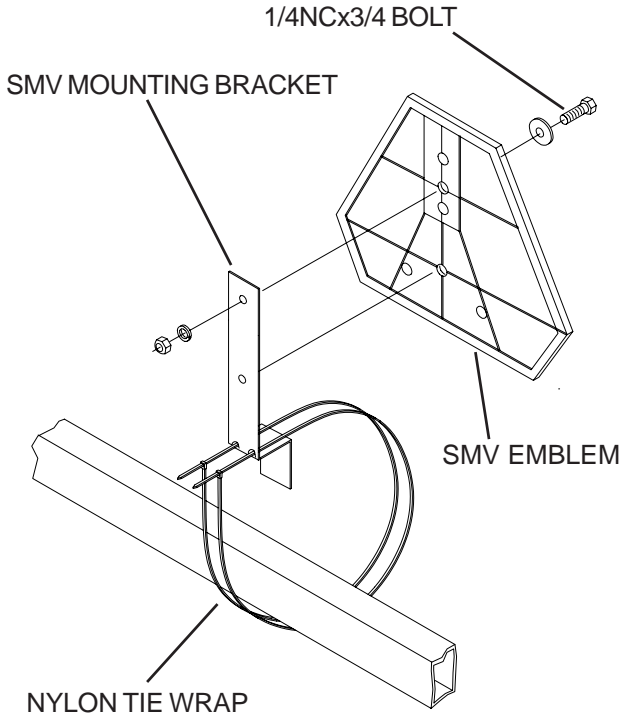

CI-77643

The bracket provided is designed to mount to numerous frame sizes and can be orientated in different positions to avoid interference with implement components.

The SMV emblem is to be secured as near to the rear and centered, or as near to the left of center of implement as practical.

Emblem is to be 2 to 6 feet above the ground measured from the lower edge of the emblem.

Keep safety decals clean. Replace any safety decals that are damaged, destroyed, missing, painted over or can no longer be read. Replacement safety decals are available through your dealer.

The purpose of the safety chain is to provide an auxiliary attaching system to retain the connection between towing and towed machine in the event of separation of the primary attaching system.

The safety chain should be hooked long enough to permit full turns. Unnecessary slack should be taken up.

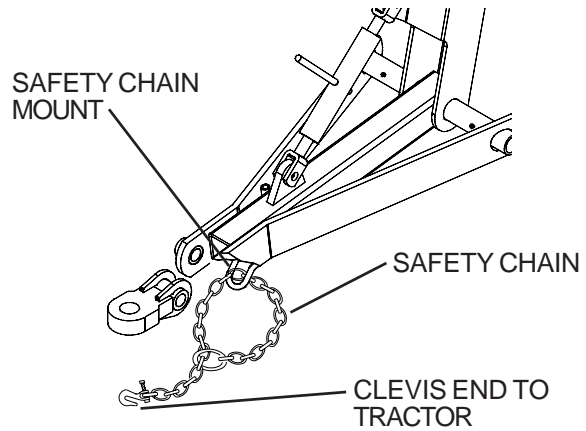

Intermediate support is to be used if there is more than 6" of unsupported chain on either side of the primary attaching point.

The intermediate support should not be mounted more than 6" from the primary attaching point. (See figure below)

The intermediate support is available from your Wil-Rich dealer.

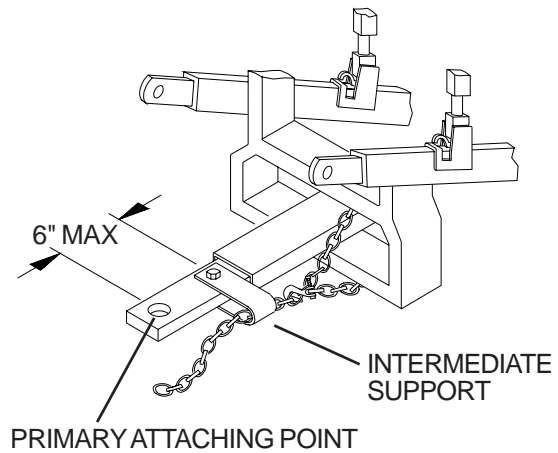

CI-77825

# OPENING BUNDLE

## Step #1

Lay bundle down, supporting frame securely 36 to 40 inches off the ground.

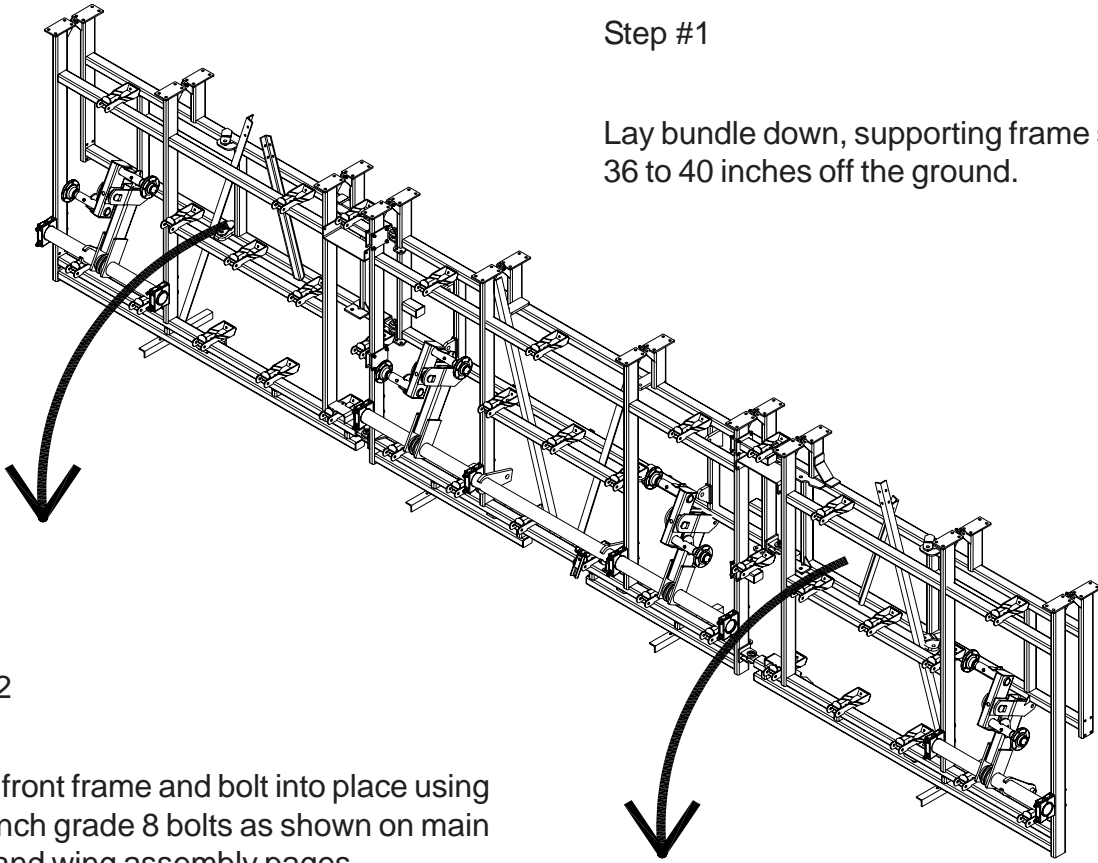

## Step #2

Unfold front frame and bolt into place using 3/4x2 inch grade 8 bolts as shown on main frame and wing assembly pages.

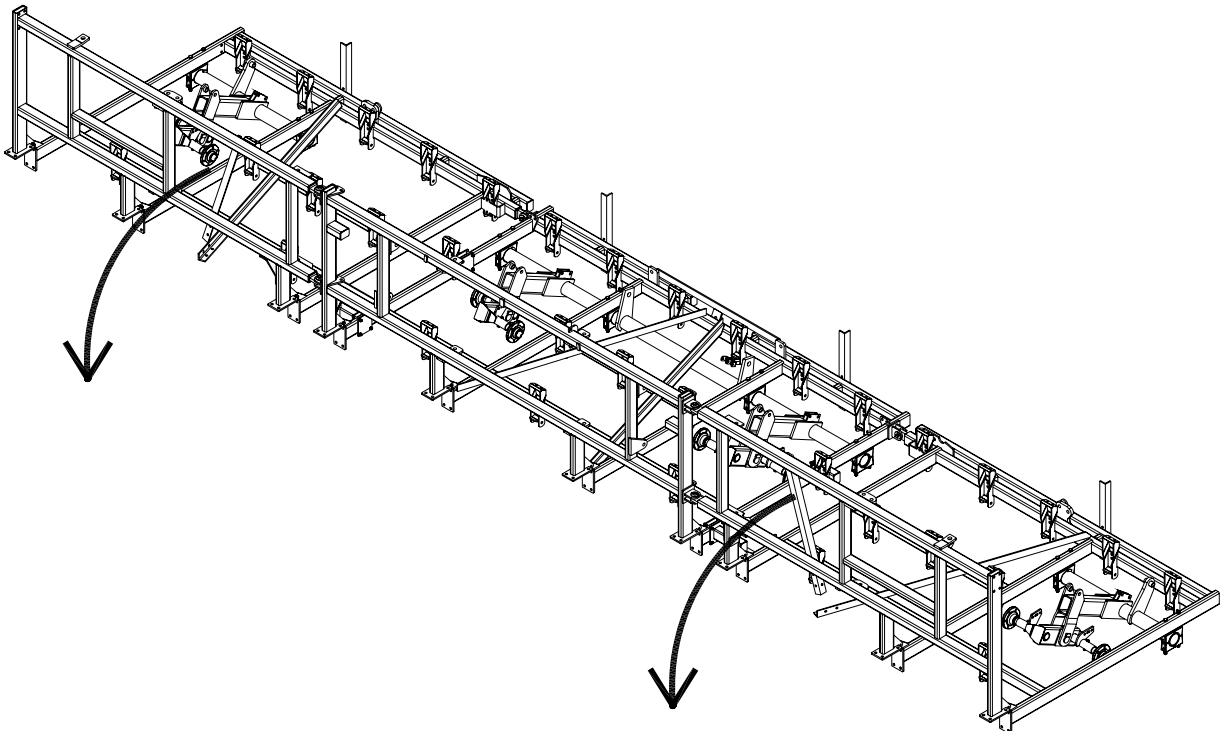

# OPENING BUNDLE

## Step #3

After bundle is unfolded and the two frame halves are bolted together remove shipping stands and brackets.

After the shipping stands and brackets are removed the rest of the cultivator may be assembled as shown in this book.

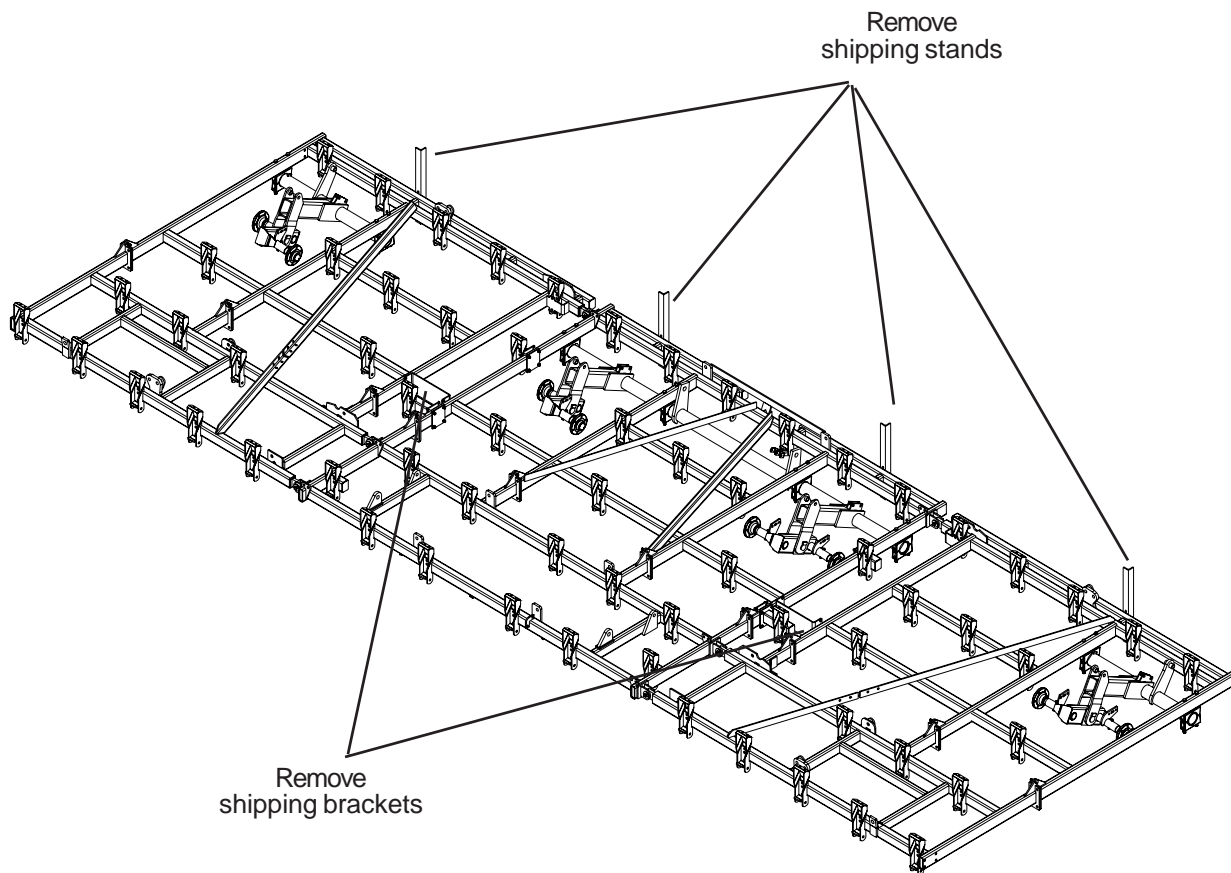



# MAIN AXLE & WALKING TANDEM

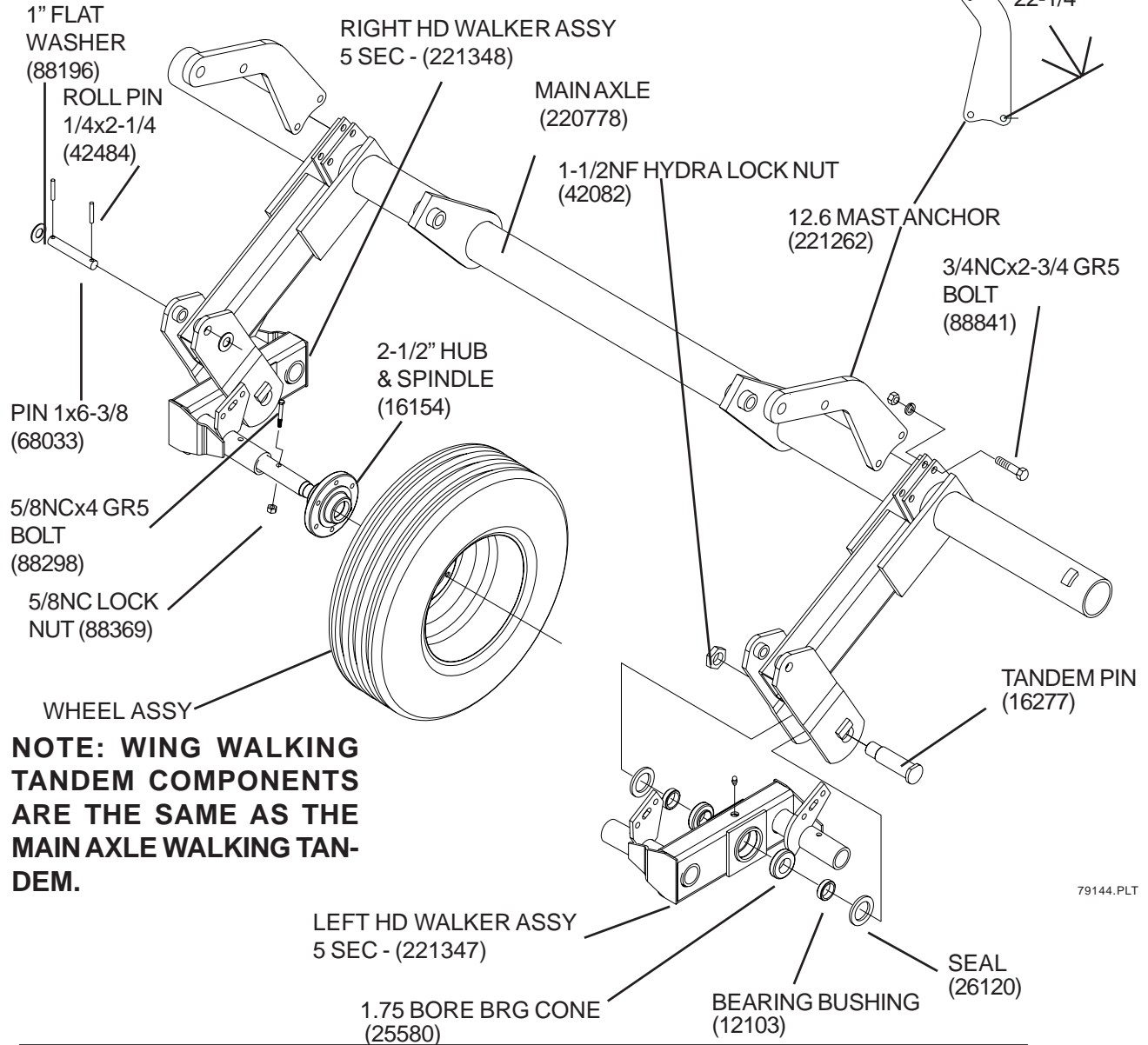

# AXLE & WALKING TANDEM 7', 9'4" & 11'8" WINGS

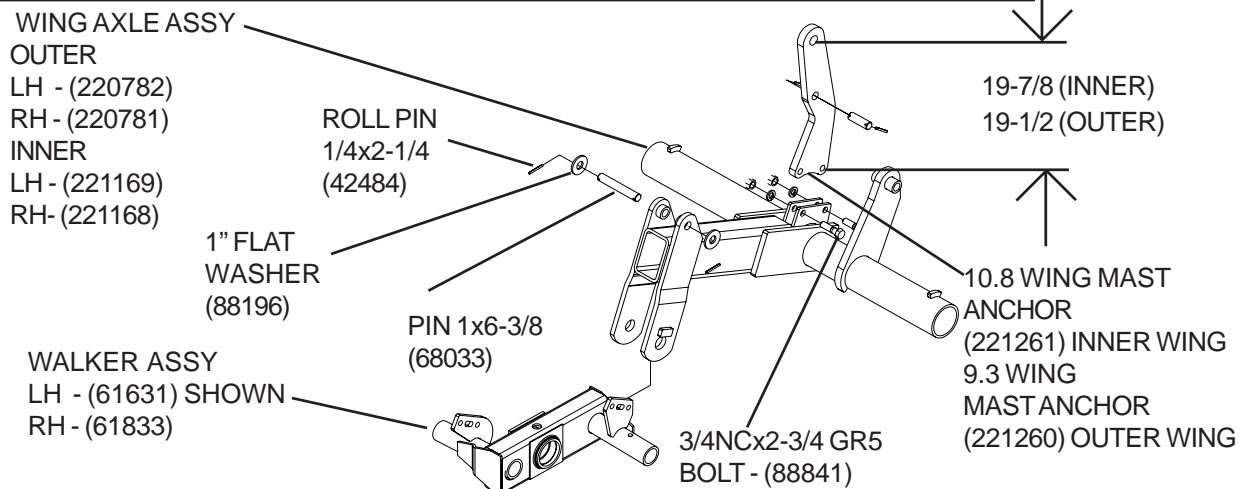

# MAIN FRAME

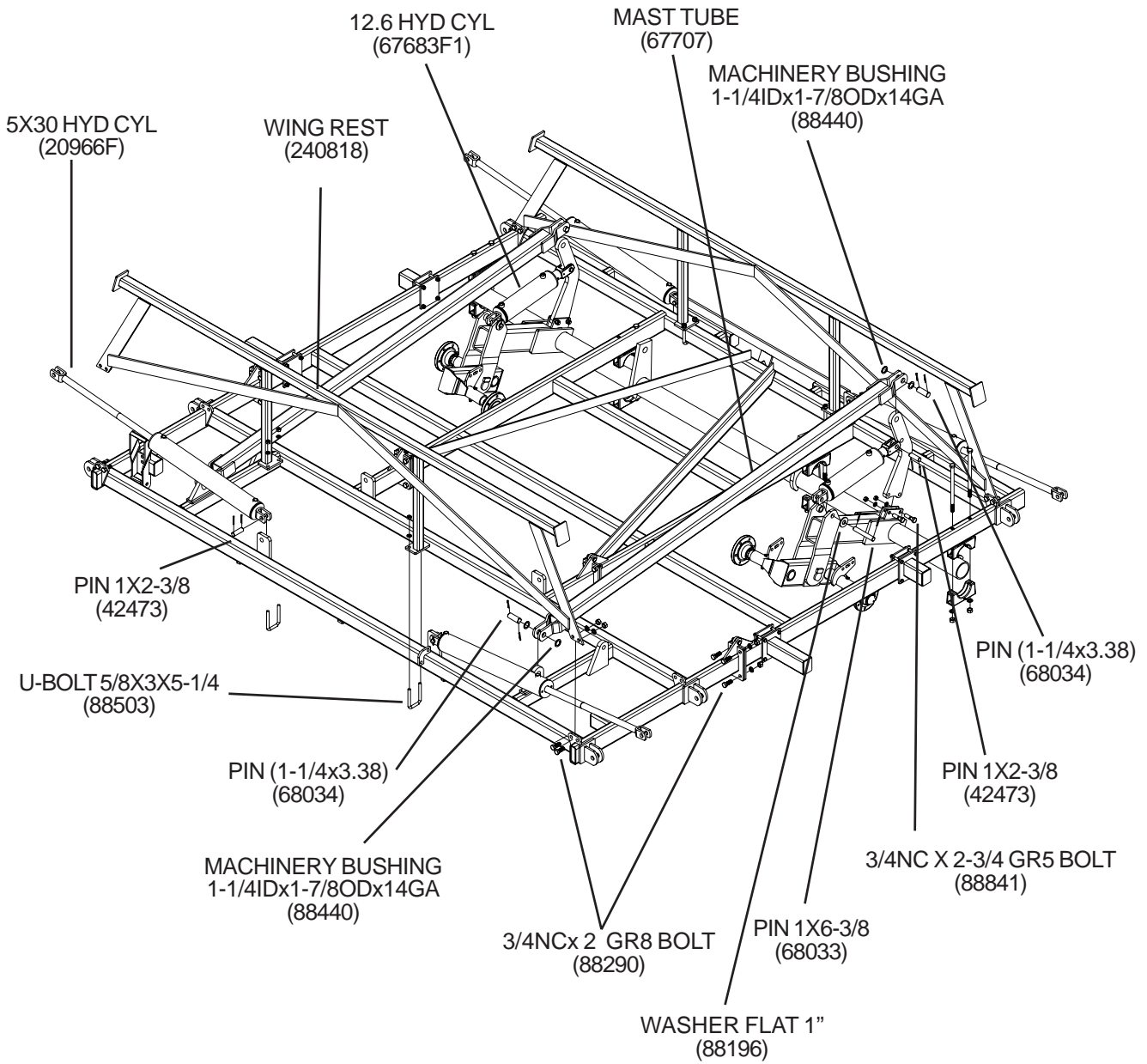

700402

**ASSY HDWR  
74302-1**

# ASSY HDWR 74302-2

# HITCH ASSEMBLY

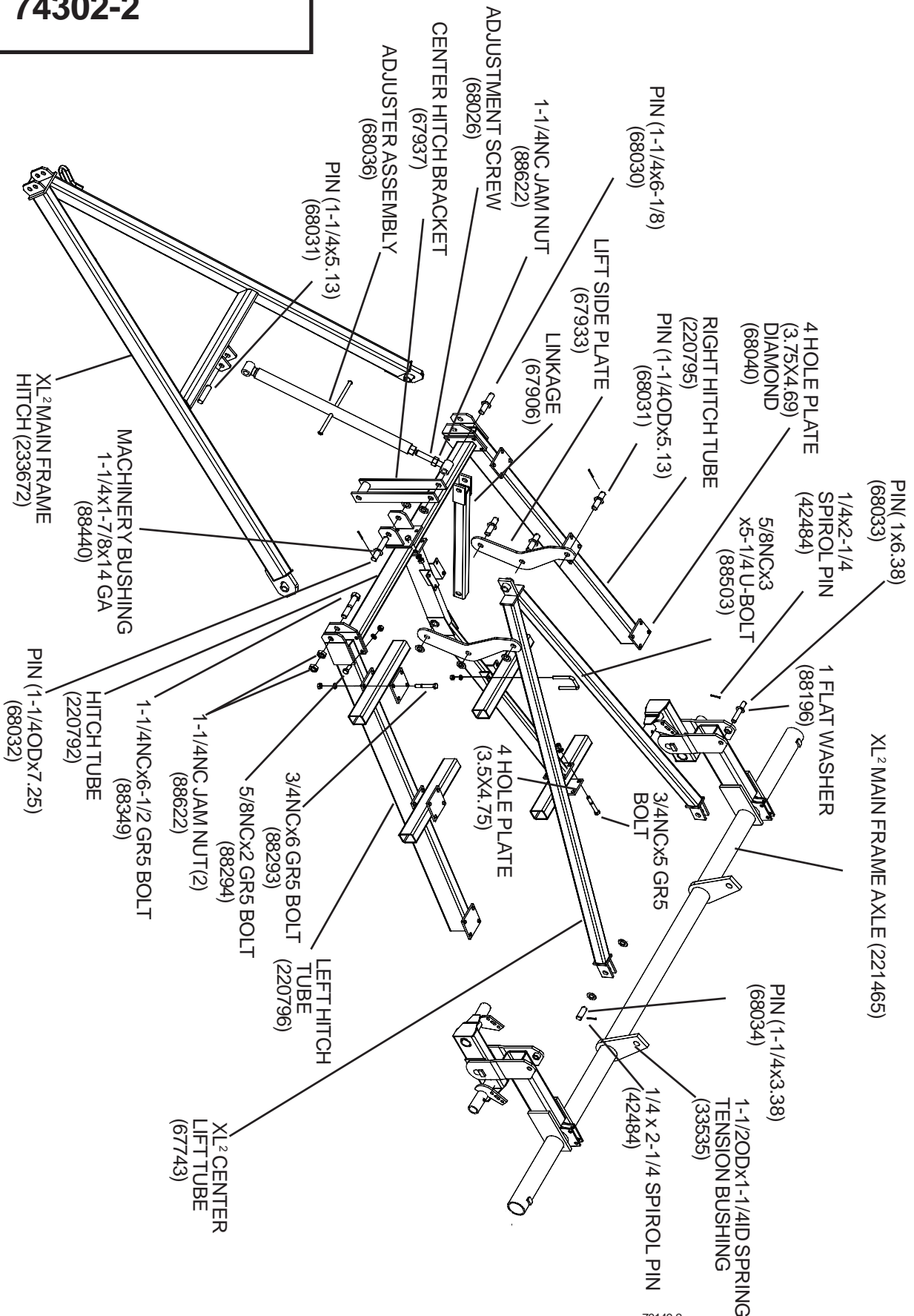

# HITCH ASSEMBLY CONTINUED

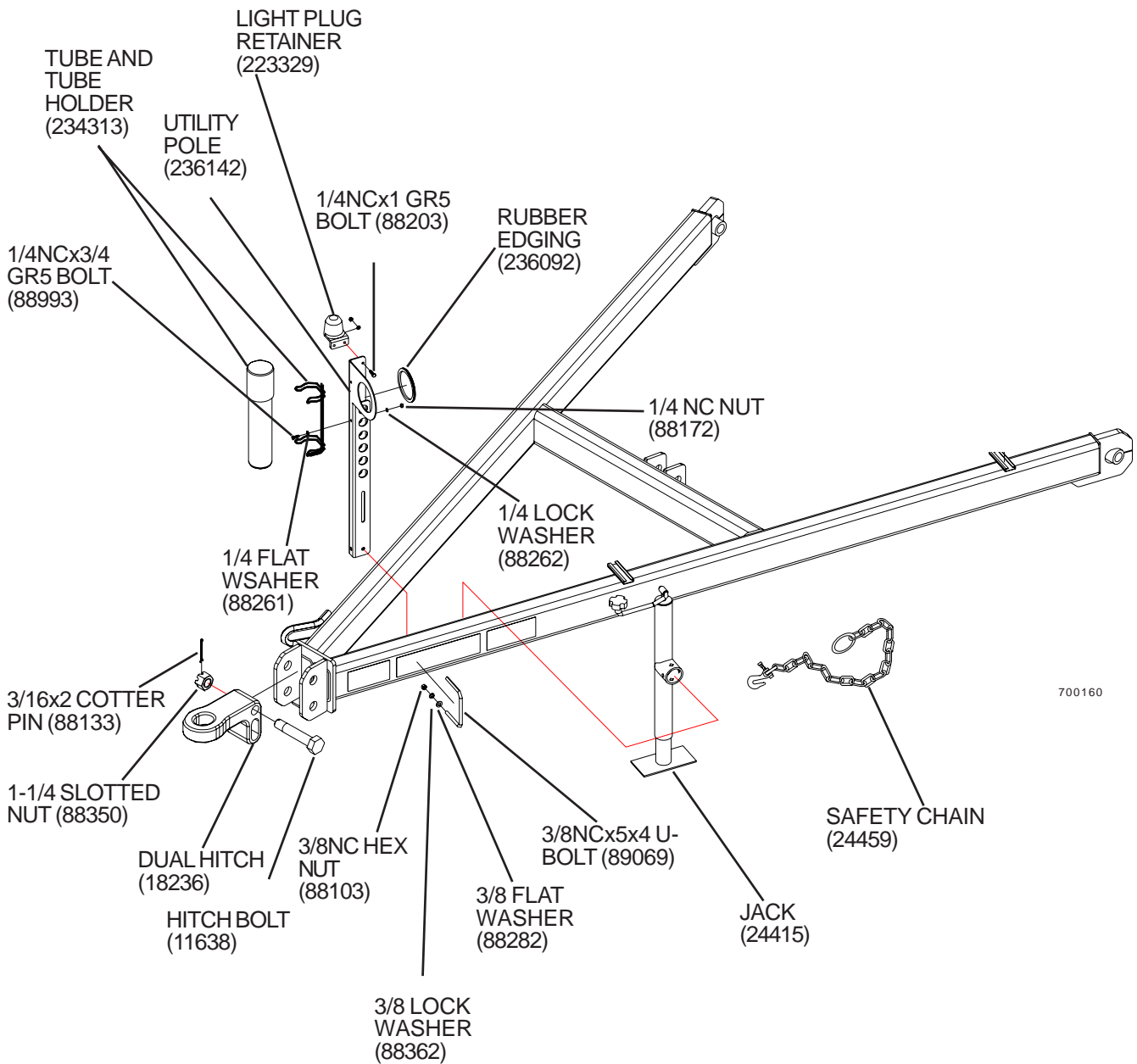

700160

# INNER WING

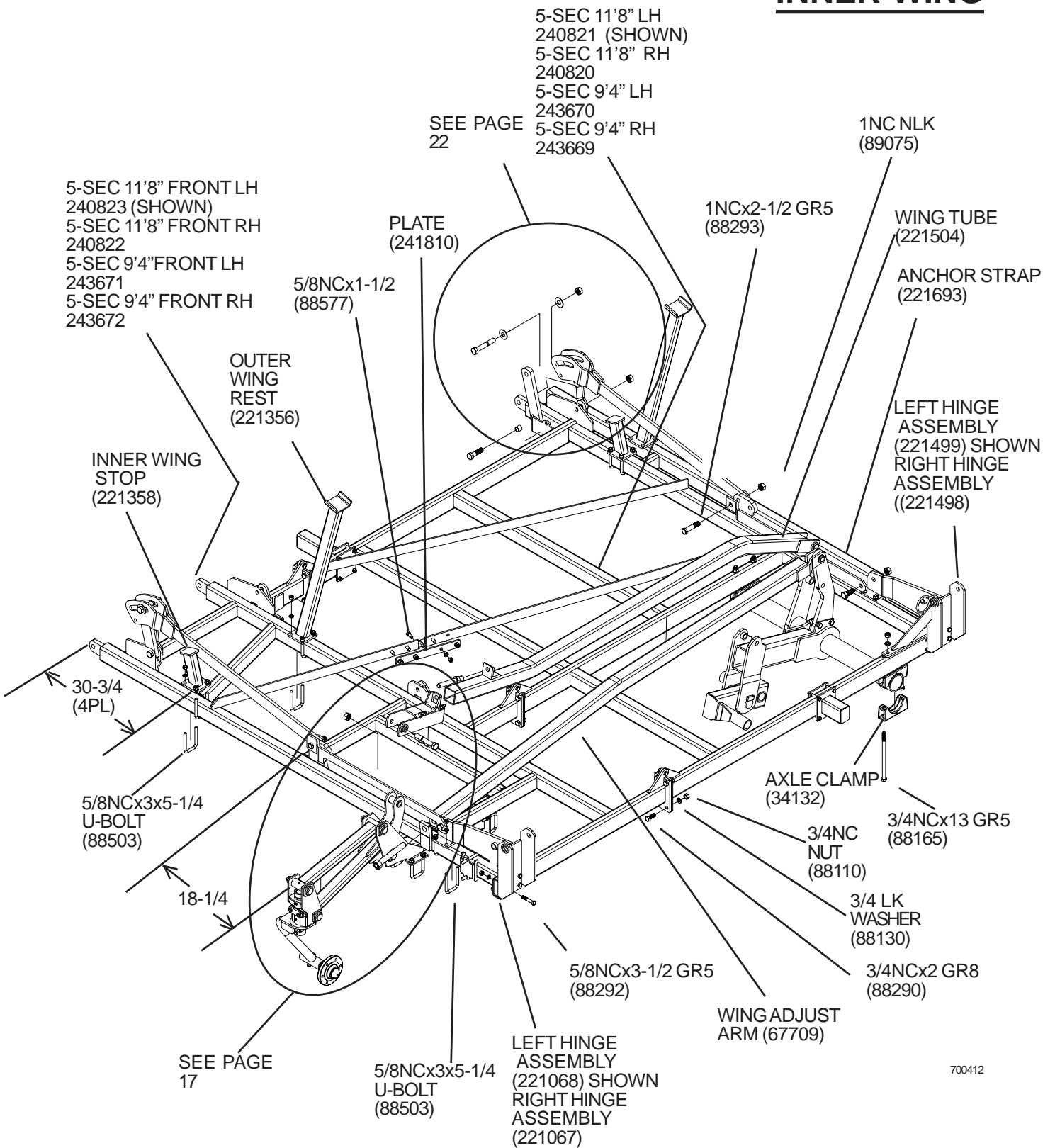

700412

NOTE: WING STOP LOCATING DIMENSIONS ARE APPROXIMATE. SPECIAL CARE SHOULD BE TAKEN THE FIRST TIME THE WINGS ARE FOLDED. WING STOP LOCATIONS MAY REQUIRE ADJUSTMENT.

**ASSY HDWR  
74305-2**

# INNER WING HINGE

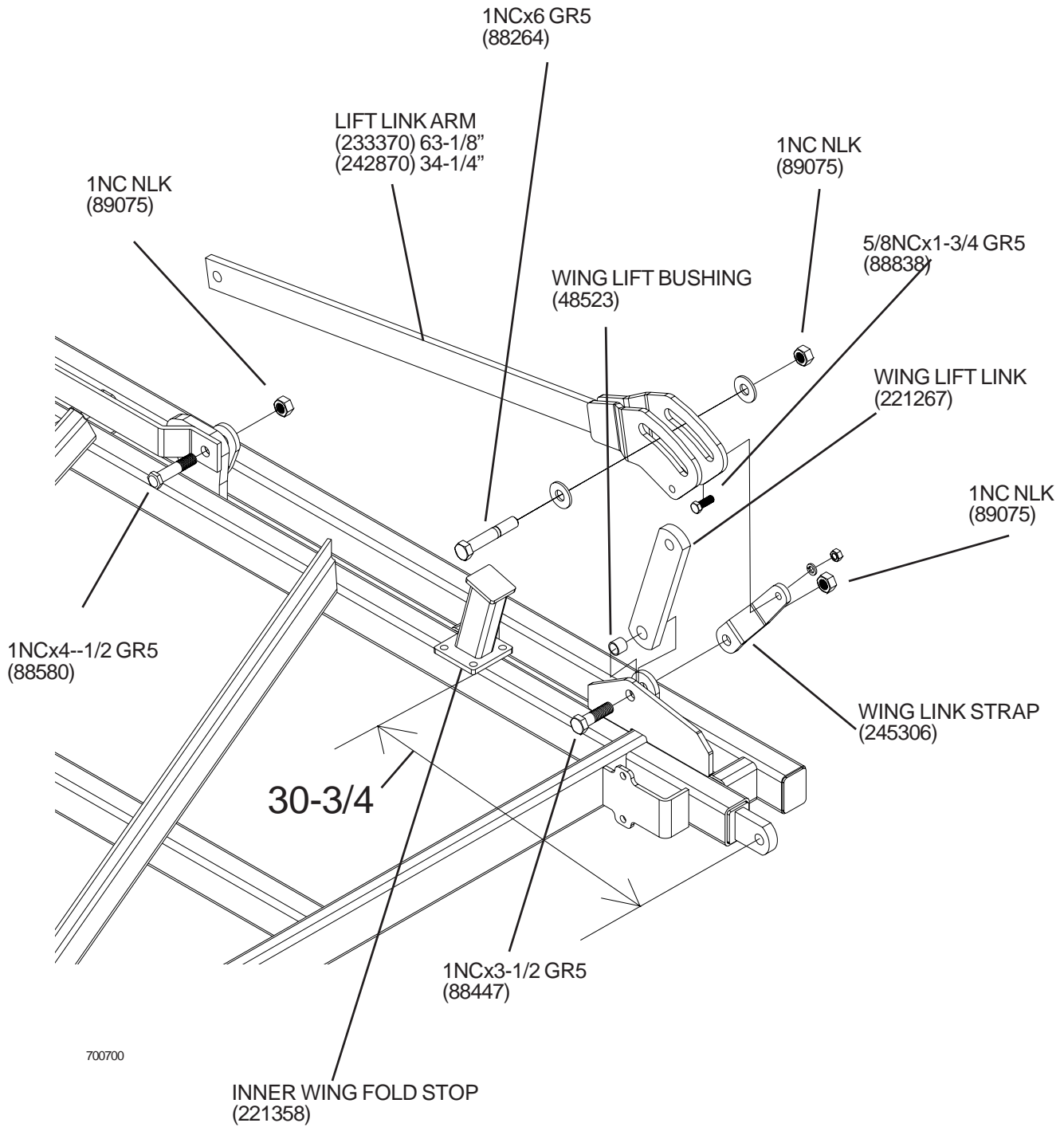

# OUTER WING

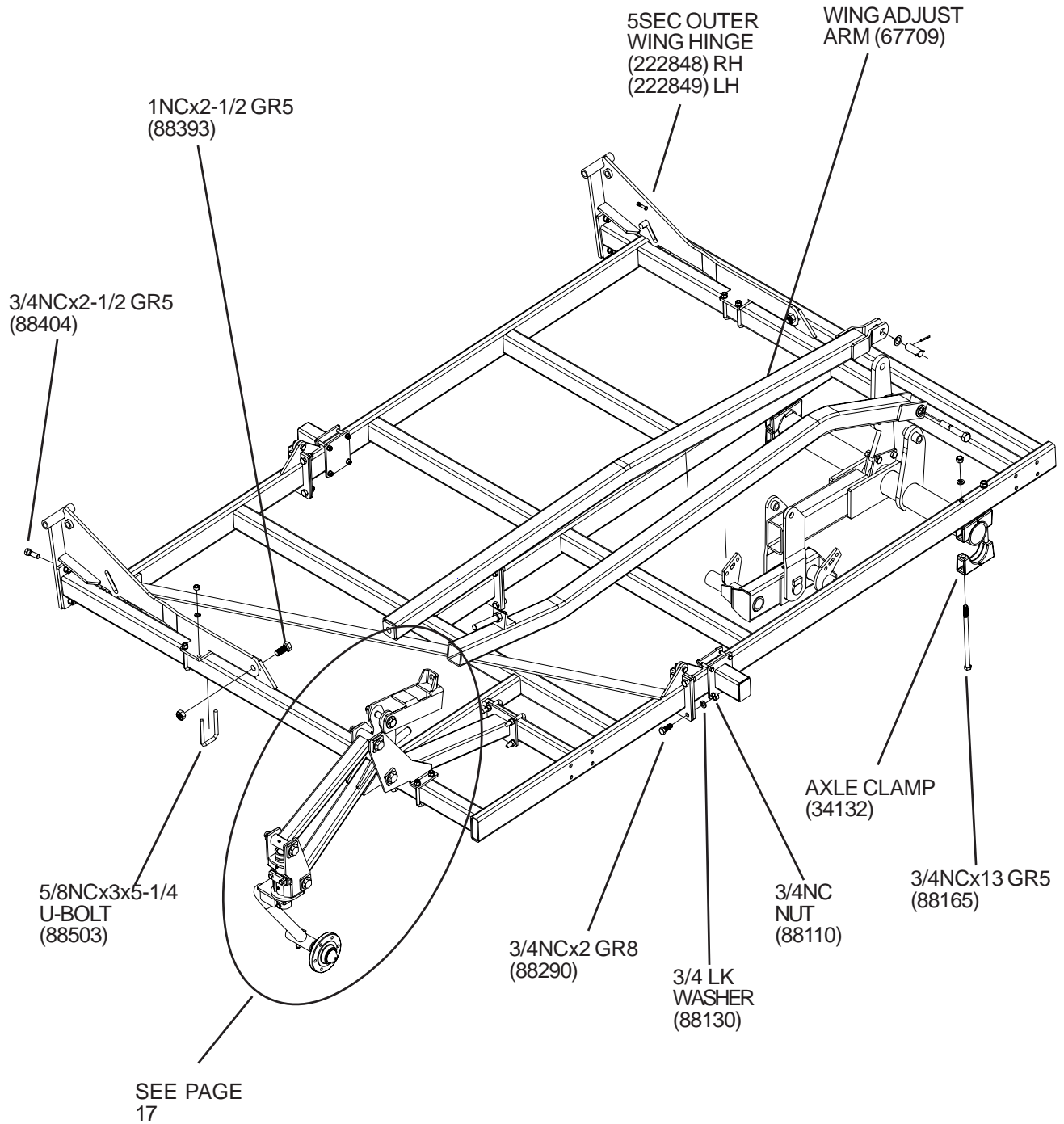

**ASSY HDWR  
74305-3**

# OUTER WING HINGE

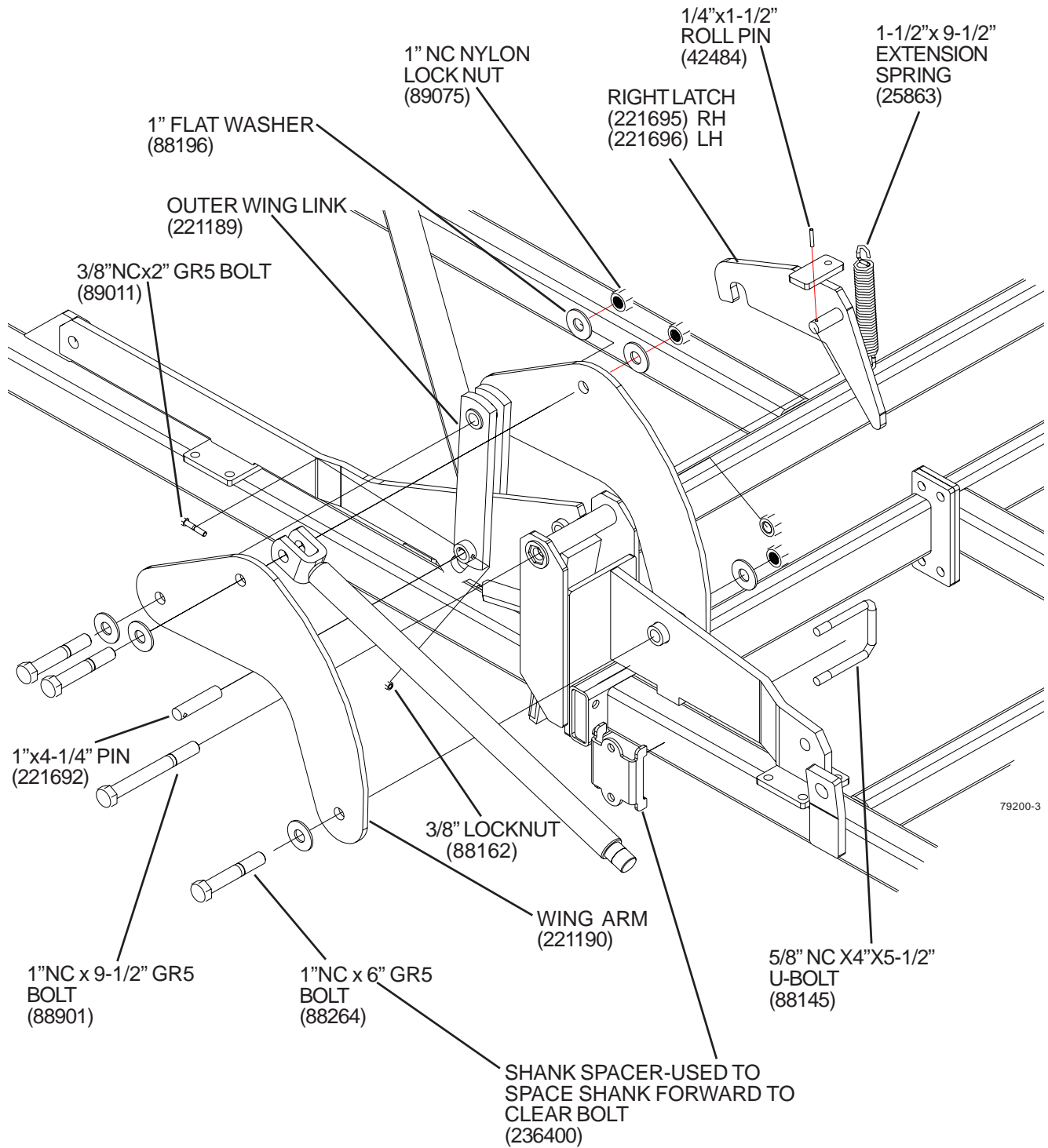



# PARALLEL LINK GAUGE WHEEL

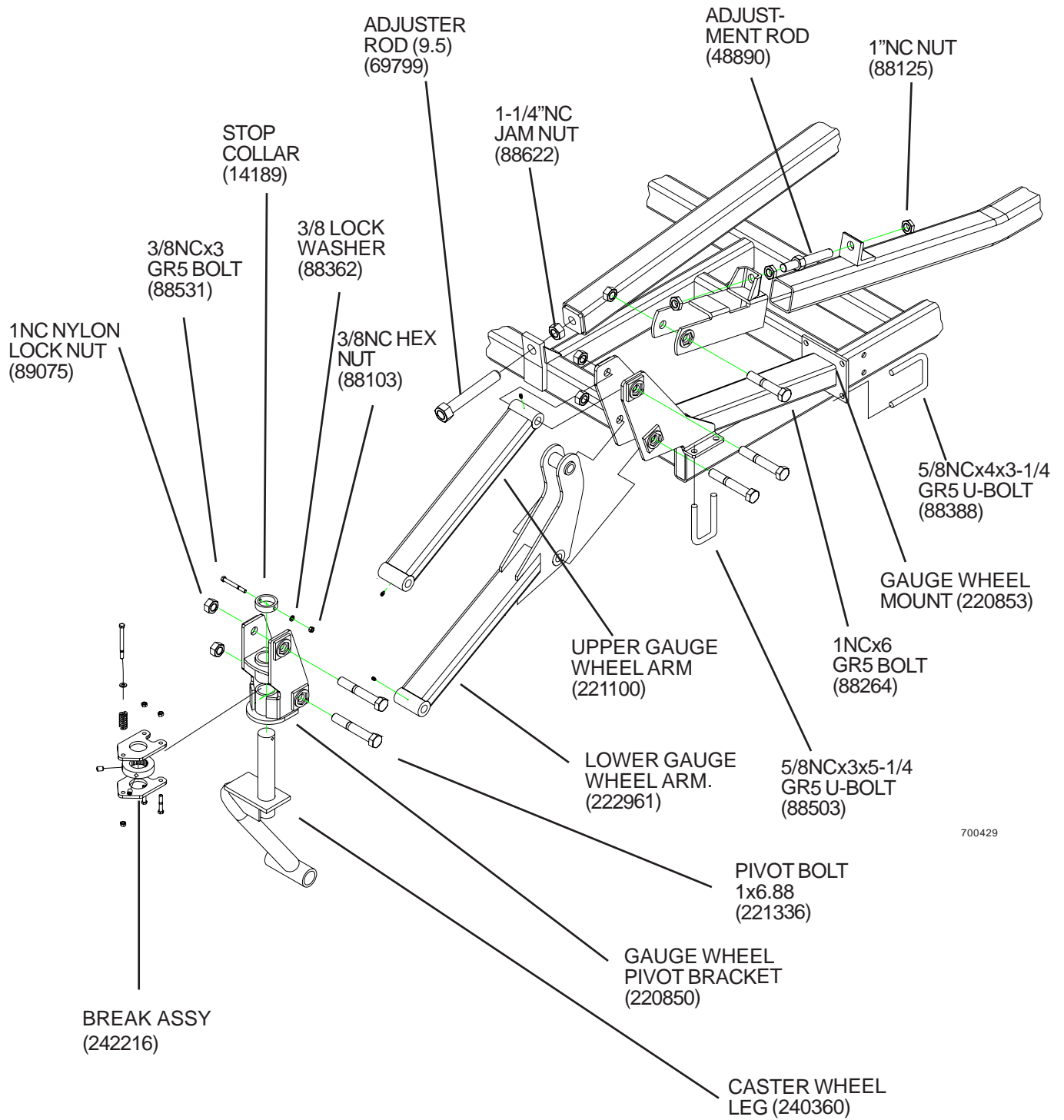

700429

**ASSY HDWR  
74302-8**

# DEPTH INDICATOR

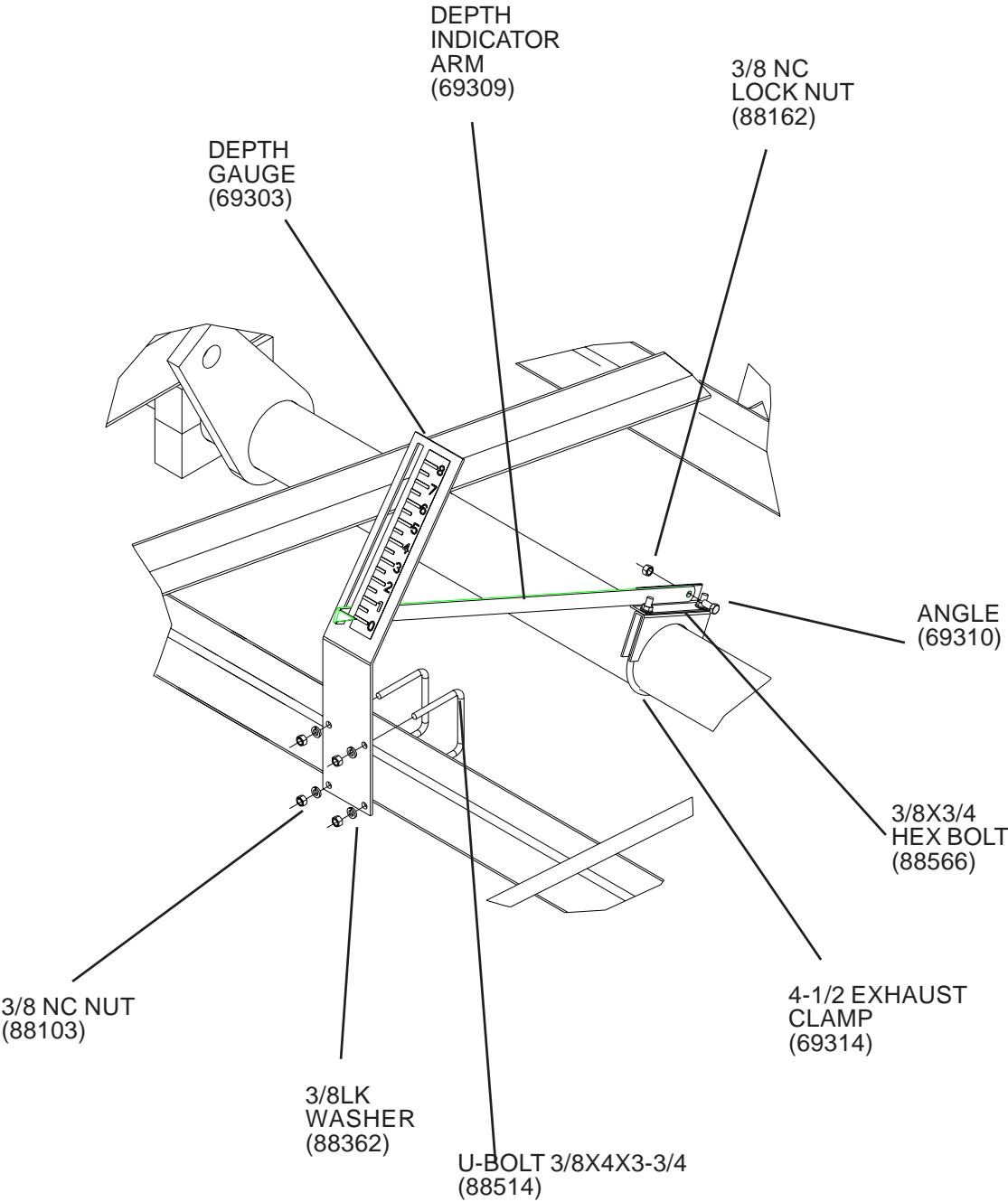

# SINGLE POINT DEPTH CONTROL

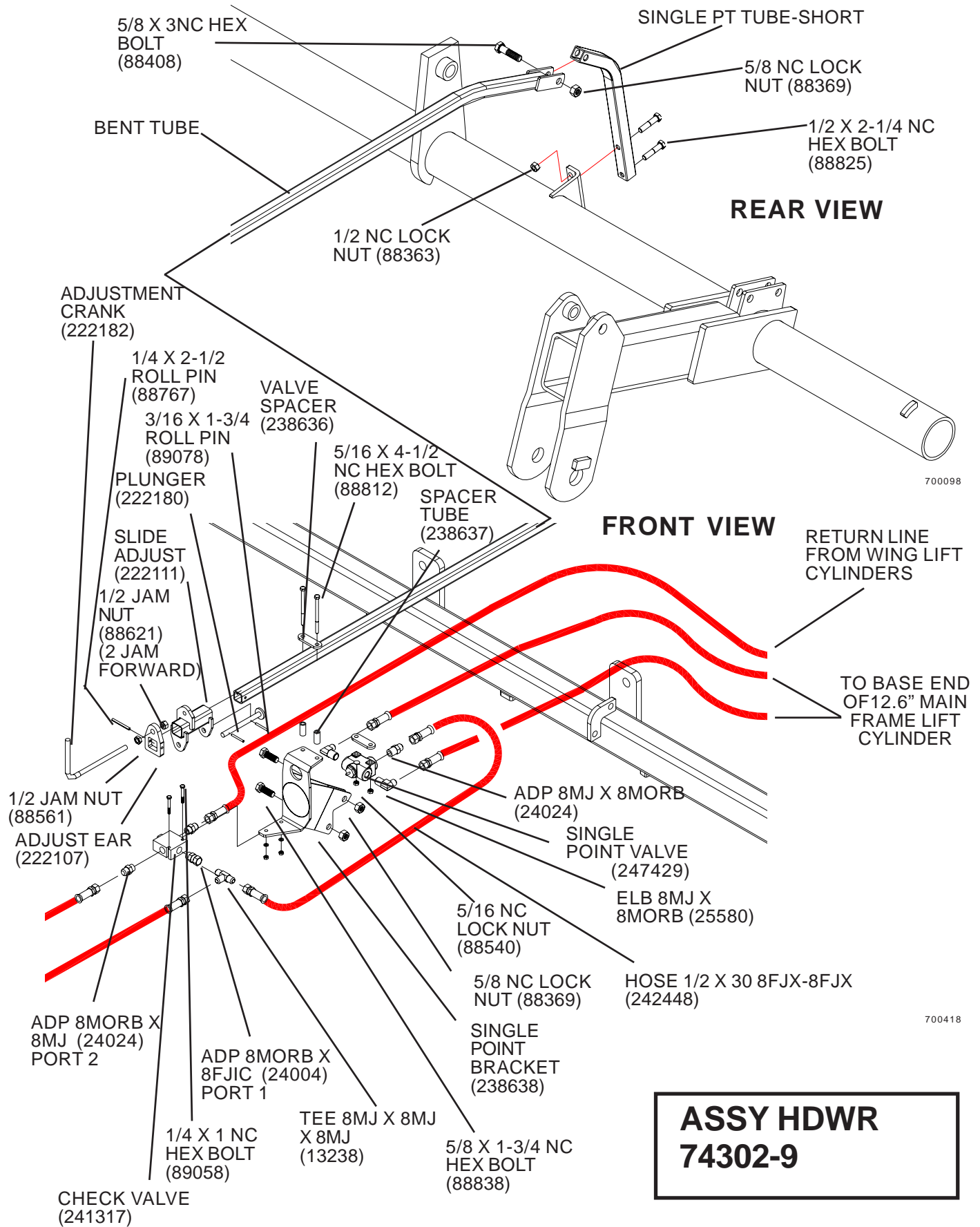

**ASSY HDWR  
74302-9**

# HANDLE ASSEMBLY

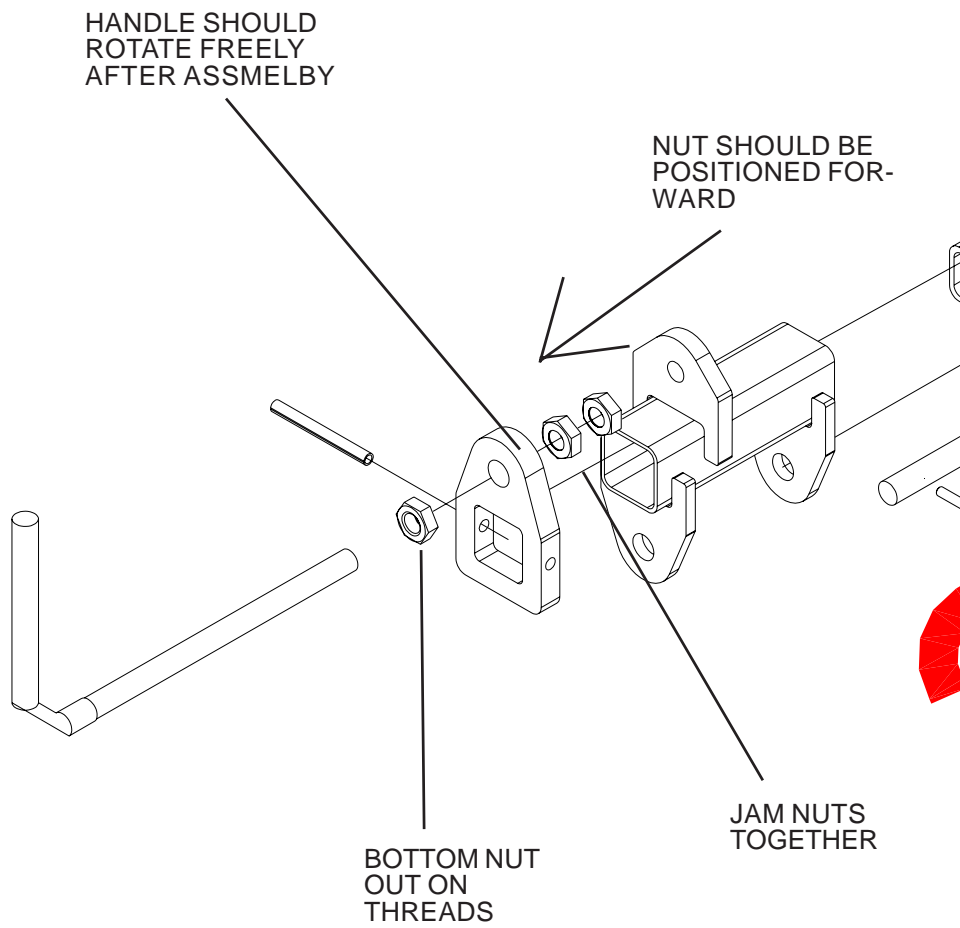

# CHECK VALVE WITH SINGLE POINT VALVE

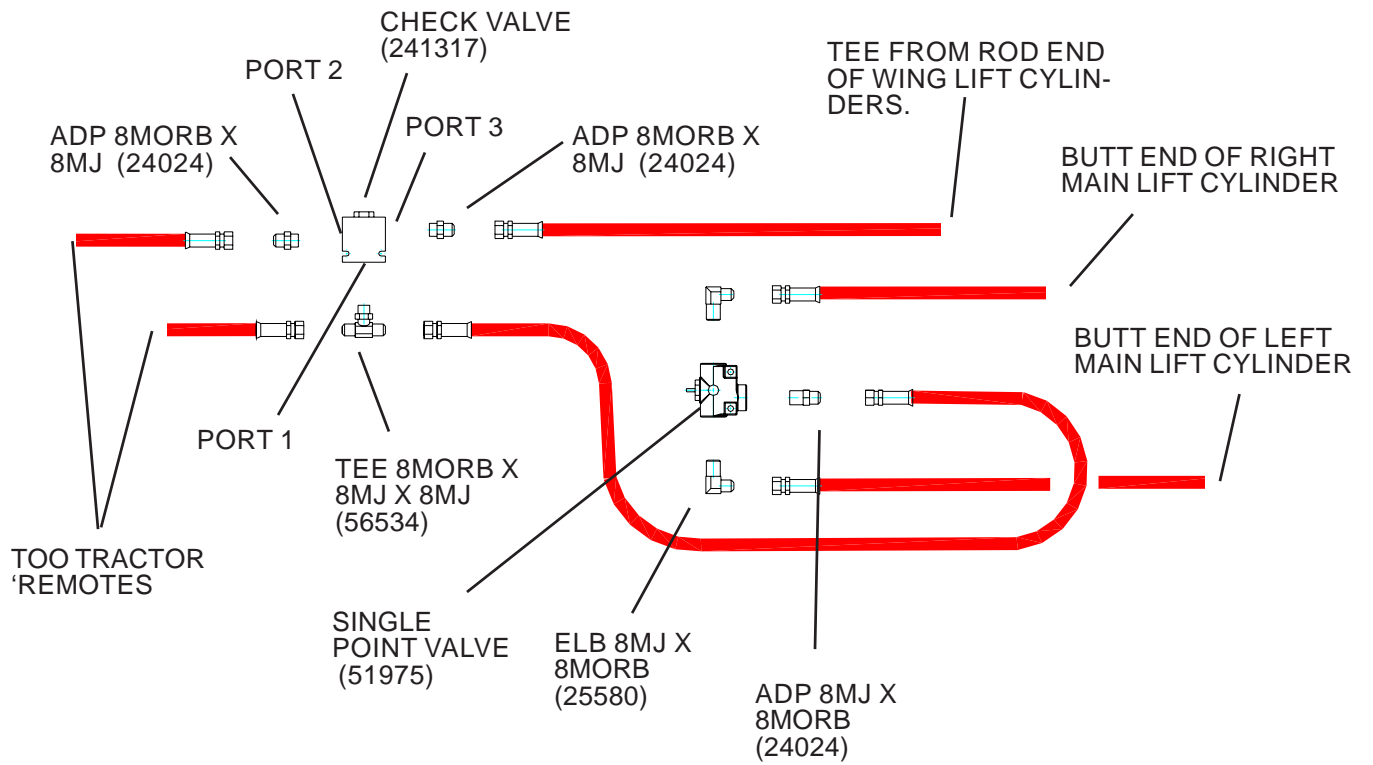

# HOSE CLAMP ASSEMBLY

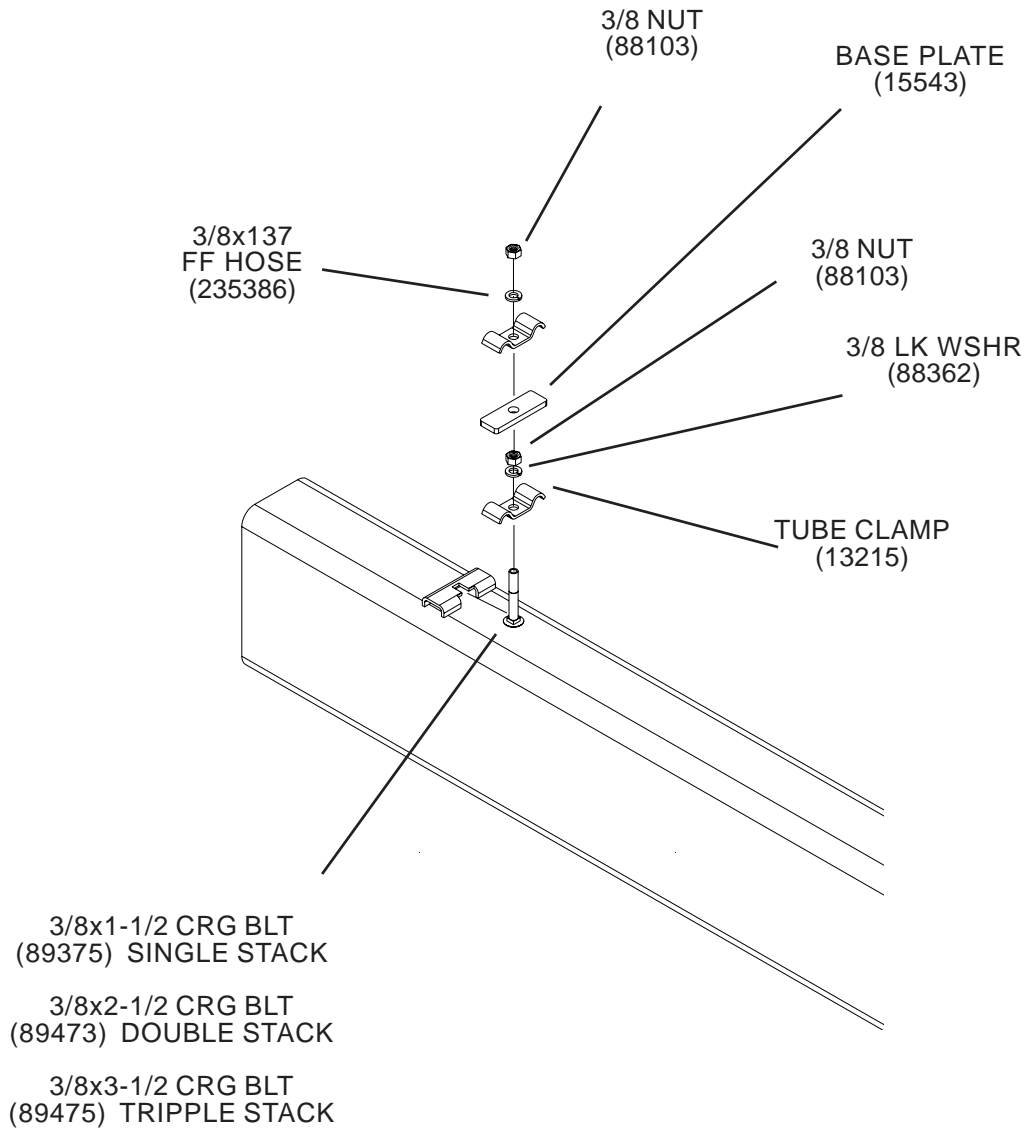

# XL<sup>2</sup> 46

## DEPTH CONTROL HYDRAULICS

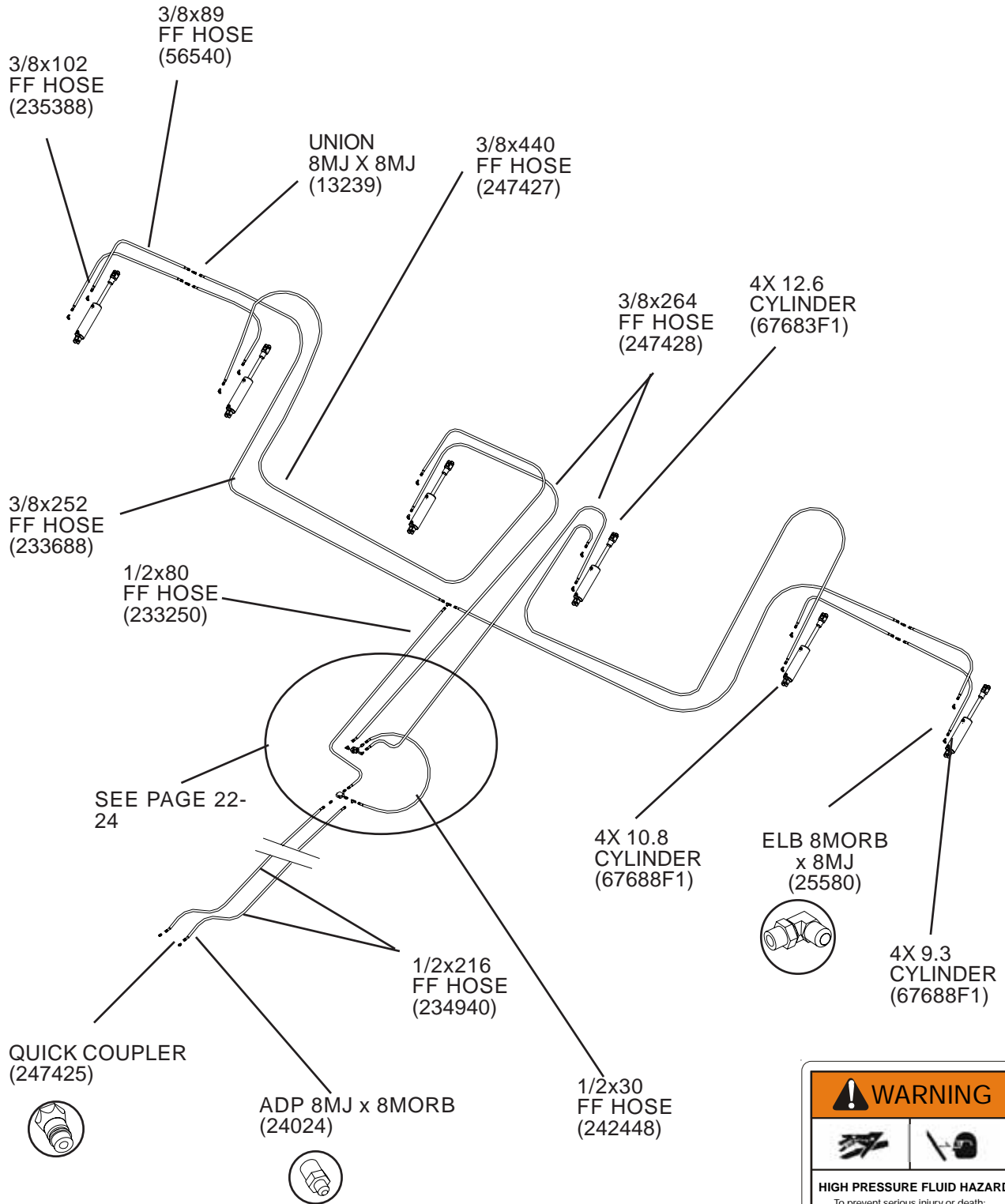

<b>WARNING</b>	
<b>HIGH PRESSURE FLUID HAZARD</b>	
To prevent serious injury or death:	
• Relieve pressure on system before repairing or adjusting or disconnecting.	
• Wear proper hand and eye protection when searching for leaks. Use wood or cardboard instead of hands.	
• Keep all components in good repair.	
<small>60711</small>	

# XL<sup>2</sup> 50

## DEPTH CONTROL HYDRAULICS

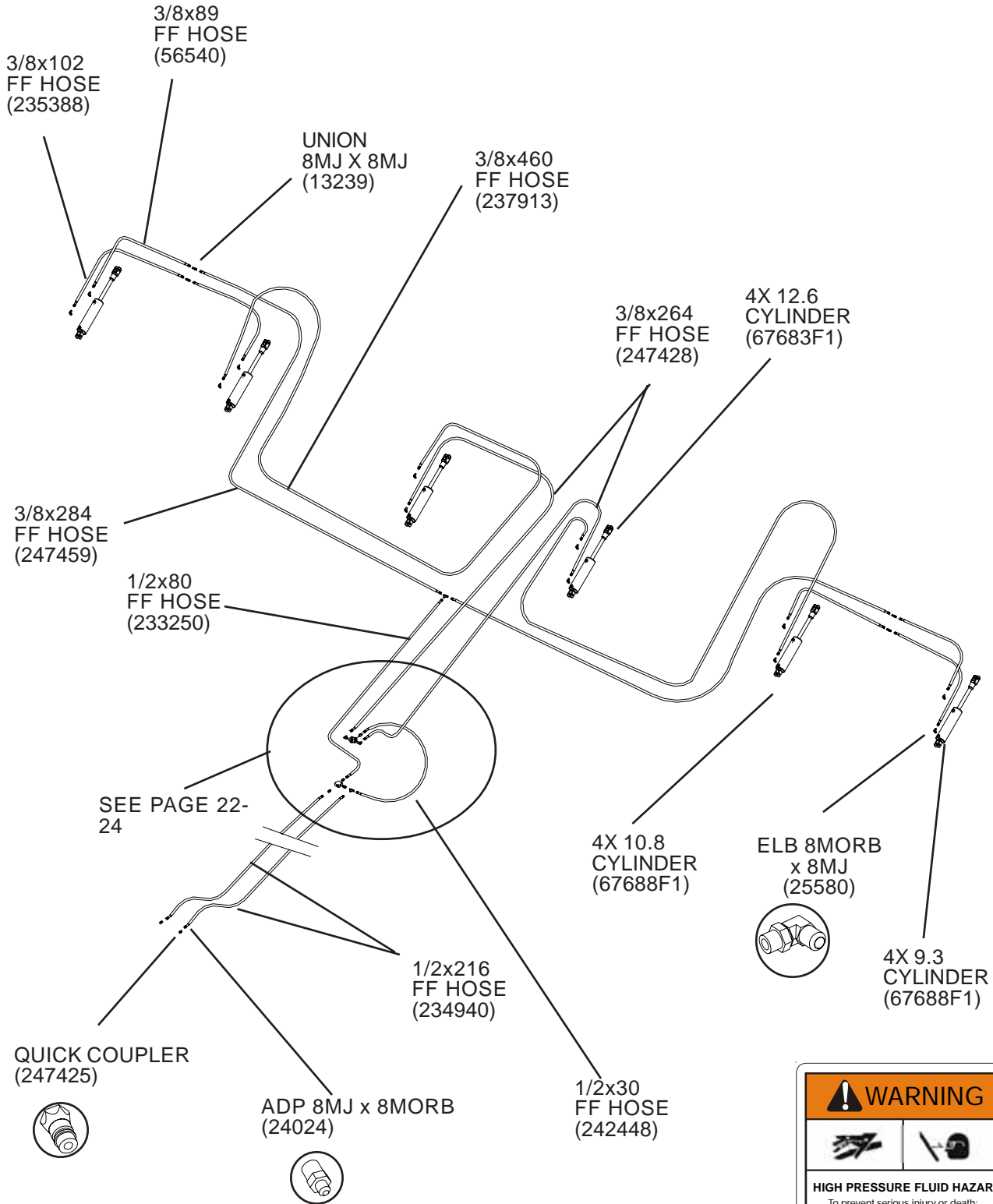

**WARNING**

**HIGH PRESSURE FLUID HAZARD**

To prevent serious injury or death:

- Relieve pressure on system before repairing or adjusting or disconnecting.
- Wear proper hand and eye protection when searching for leaks. Use wood or cardboard instead of hands.
- Keep all components in good repair.

60711



# XL<sup>2</sup> 55

## DEPTH CONTROL HYDRAULICS

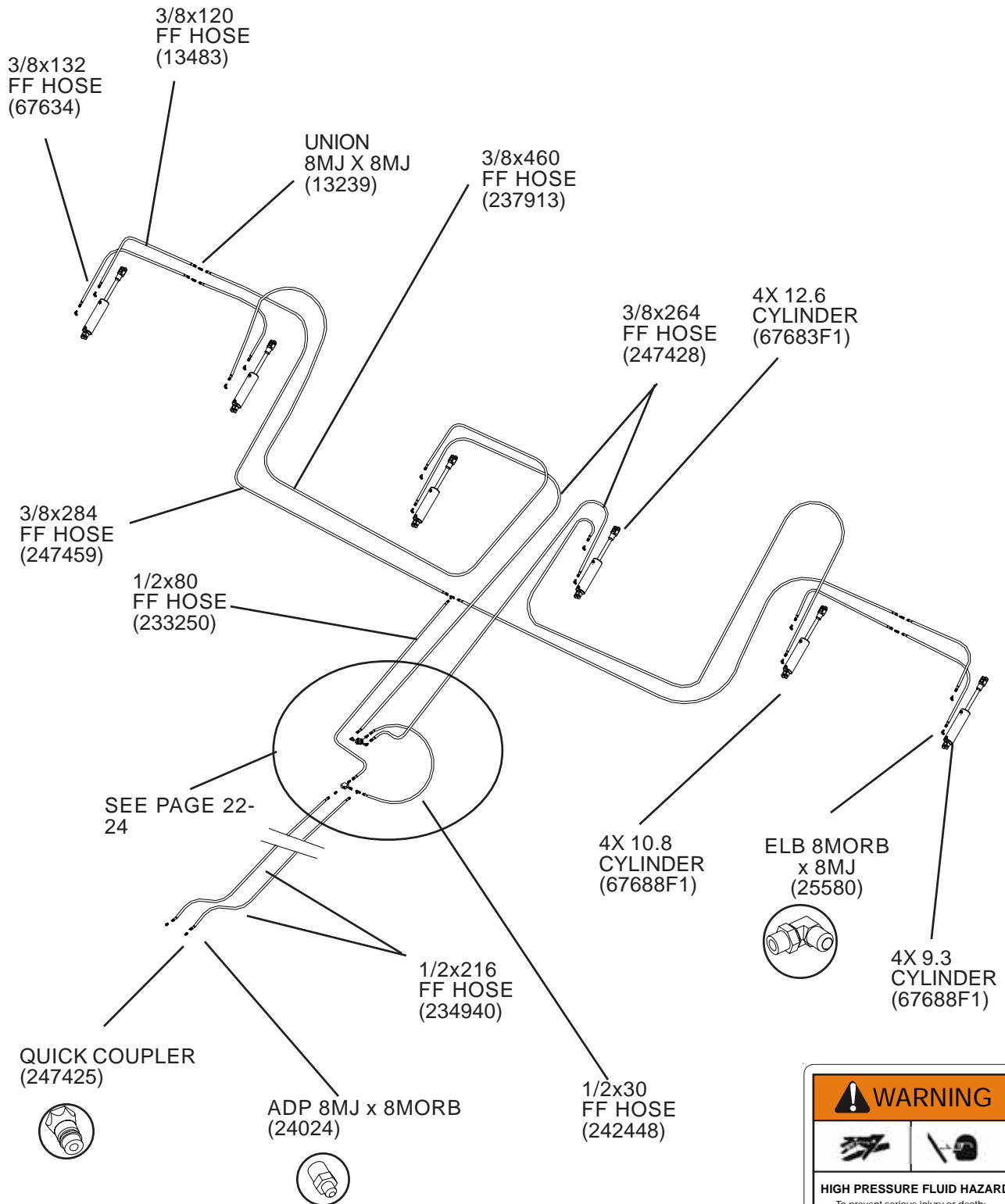

<b>WARNING</b>	
<b>HIGH PRESSURE FLUID HAZARD</b>	
To prevent serious injury or death:	
• Relieve pressure on system before repairing or adjusting or disconnecting.	
• Wear proper hand and eye protection when searching for leaks. Use wood or cardboard instead of hands.	
• Keep all components in good repair.	

60711

# XL<sup>2</sup> 46

## FOLD HYDRAULICS

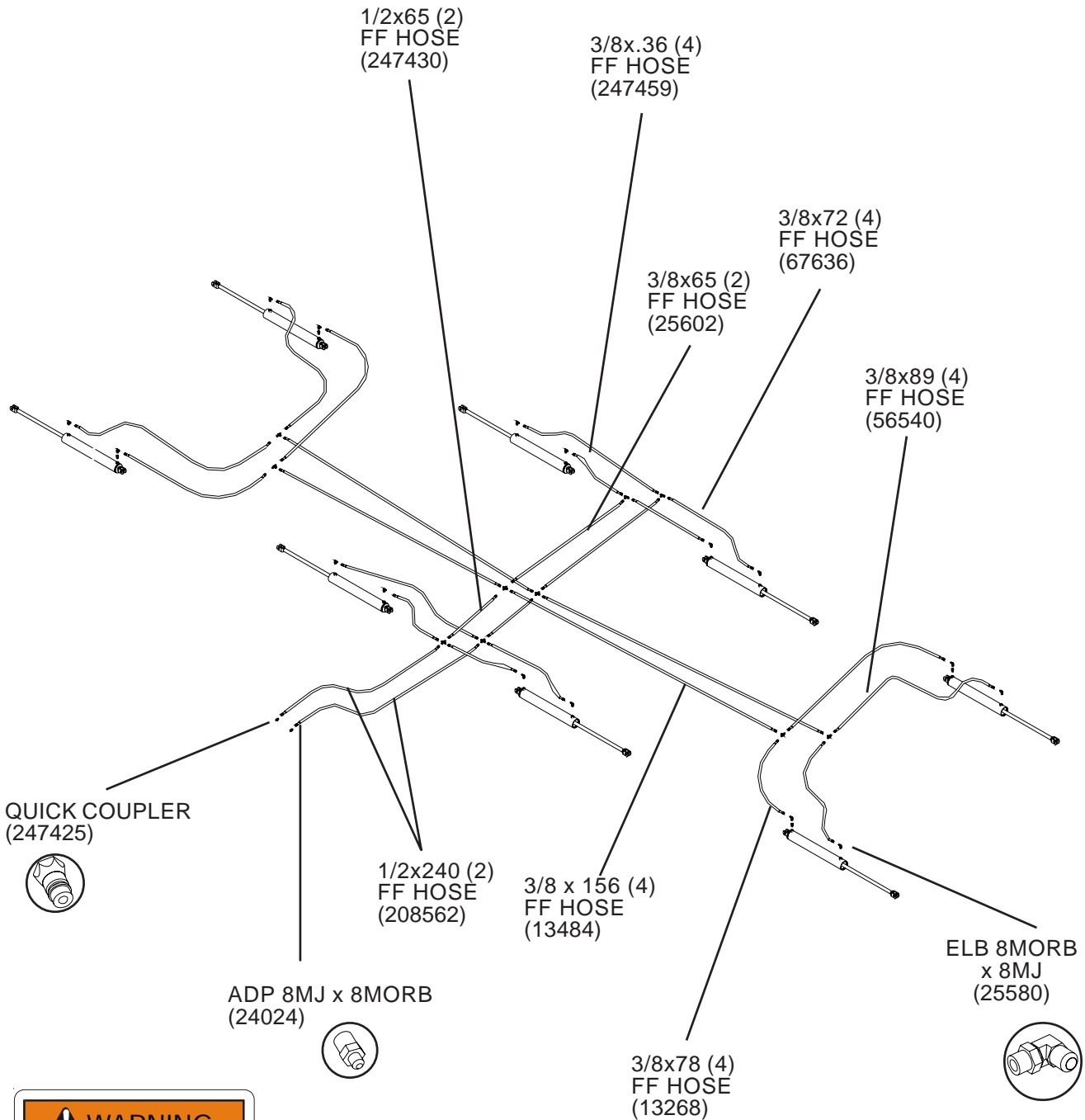

**WARNING**

**HIGH PRESSURE FLUID HAZARD**

To prevent serious injury or death:

- Relieve pressure on system before repairing or adjusting or disconnecting.
- Wear proper hand and eye protection when searching for leaks. Use wood or cardboard instead of hands.
- Keep all components in good repair.

50711

# XL<sup>2</sup> 50 & 55

## FOLD HYDRAULICS

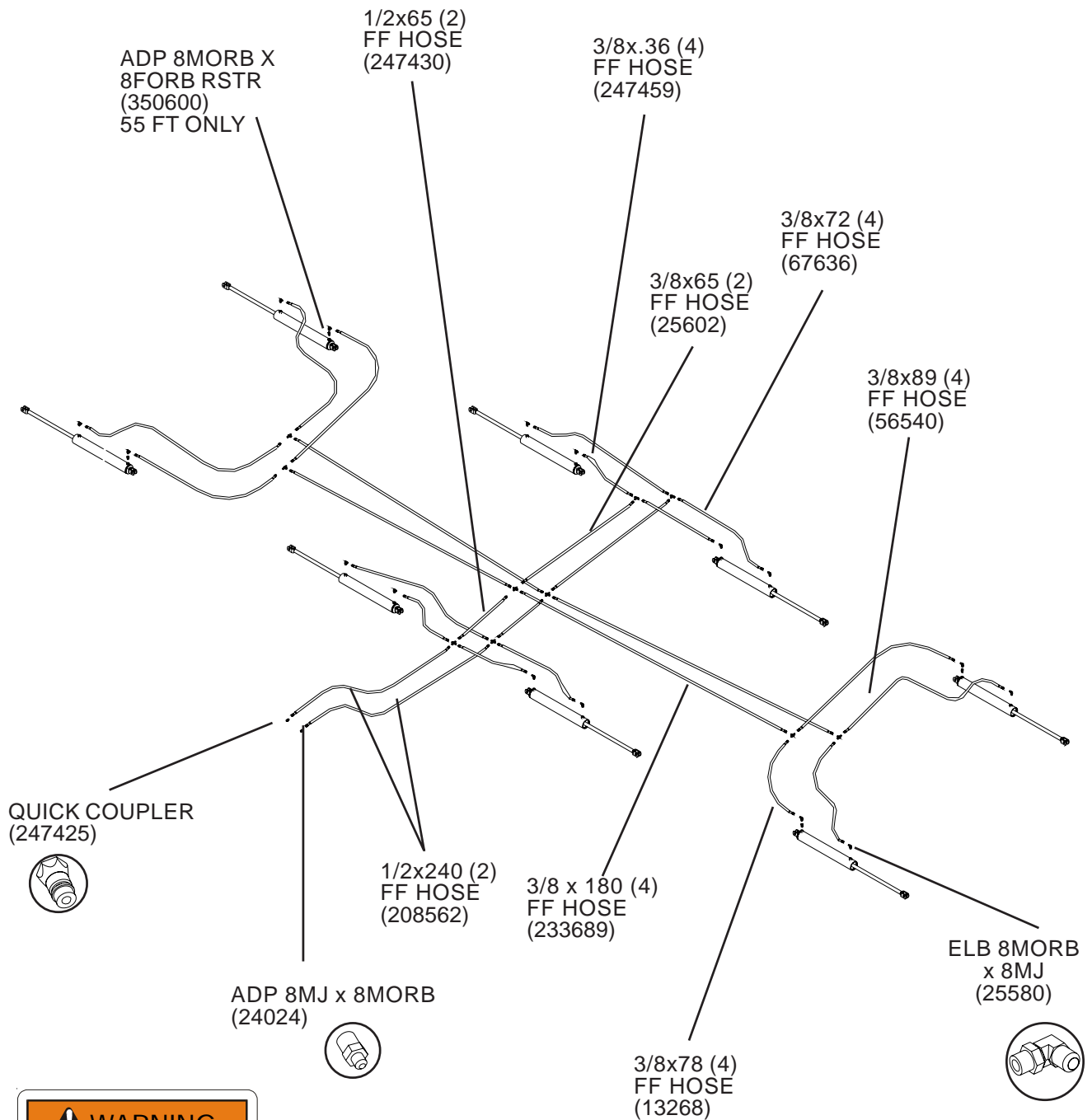

**WARNING**

**HIGH PRESSURE FLUID HAZARD**

To prevent serious injury or death:

- Relieve pressure on system before repairing or adjusting or disconnecting.
- Wear proper hand and eye protection when searching for leaks. Use wood or cardboard instead of hands.
- Keep all components in good repair.

60711

## Initial Assembly and Charging of Lift Systems

All WIL-RICH lift systems should be assembled as noted in the appropriate assembly manual. For best functional results the following steps should be followed.

- 1) Position the main lift cylinders in the locations and connect the hydraulic circuitry as shown. Attach the base end of all cylinders but do not connect the rod ends. Support the cylinders to allow the rods to extend without machine contact.
- 2) Most fittings, except the connection tips at the tractor end and some valves, are JIC or O-ring type fitting. JIC and O-ring fitting do not require any type of thread compound to seal properly. **NOTE: Take care to keep all connections, fitting, hose, etc as clean as possible.**
- 3) Where pipe threads are used a thread-sealing compound should be used. **NOTE: Do not use Teflon type tape on any hydraulic circuitry; use an appropriate liquid compound. If any tape or contaminate enters the system it can clog the bypass hole.**
- 4) With all connections secured and the cylinders supported to allow rod extension apply pressure to the system.

The main or base cylinder should extend as oil flows into the base of the cylinder. Because there is air in the remaining cylinders and in the connecting hoses the outer cylinders may extend quickly. Just because the cylinders are extended does not mean the system has been purged. Continue to direct oil into the system until all cylinders have extended fully. **NOTE: the cylinders will only bypass when the cylinders are fully extended. By allowing the cylinders to extend without having to lift the unit you allow the cylinders to reach the bypass position.**

Keep in mind that all the oil going to the outer cylinders must be bypassed through the base cylinder bypass hole and subsequent cylinders. This will take some time, in some cases a considerable amount of time. On large unit with multiple wings and lift cylinders it will take longer to charge the system and a large amount of oil will be required. Check that your tractor has sufficient oil capacity; you may need to add oil to your reservoir. Also, because of the need to force all the oil through the by-pass holes you will need to have a system pressure of 2500-3000 psi.

Once all cylinders on the unit have been fully extended, retract the cylinders and again extend fully. Hold the cylinders in the extended (bypass) position for a few minutes, retract the cylinders and observe that the cylinders are working in sequence. Attach the cylinder rod ends to the anchor points of the unit. Raise and lower the unit and check to ensure the unit is moving in a level manner.

If the cylinders have been properly bypassed, all cylinders and hoses should be filled with oil with no air in the system. In actuality there will still be some air in the system as it is unlikely all air has been purged from the system. Even with some air in the system the cylinders should move in sequence and lift and control the depth of the unit. If the cylinders don't seem to be bypassing it may indicate that some debris has blocked the bypass hole. Because the hole may be blocked it is critical to maintain clean oil. Protect the complete hydraulic system at all connection points.

## Wing Fold System Information

WIL-RICH products use a number of varying designs to fold implement wings. All utilize a two-way cylinder of varying diameters and strokes. All wing fold cylinders use an integral or in-line restrictor to control the cylinder stroke speed. This restrictor is critical to the safe operation of the unit and use of non-WIL-RICH cylinders is not recommended.

Assembly of the wing fold circuitry and mounting of the fold cylinders is outlined in the appropriate Assembly Manual. It is important to properly charge the wing fold cylinders and circuitry in the assembly process. Mount the base of all wing fold cylinders to their anchor points as noted. Tighten all hoses and fittings per specifications. **Before attaching the rod ends of any wing fold cylinders fully extend and retract all cylinders to ensure that the cylinders are filled with oil.** This can be made easier by supporting the cylinders with some type of blocking. Support so that all cylinder rods can be extended and retracted without machine interference. After the cylinders are fully charged attach the rod end of the cylinders to the appropriate anchor. Pressurize the system and check for proper wing fold.

When folding any winged implement make certain that the wing fold cylinders have been fully retracted. **Any time the unit is to be stored with the wings folded, whether connected to the tractor hydraulic system or disconnected, it is critical to relieve any pressure from the wing fold circuit. On older tractor, shutting the tractor down, moving the control lever back and forth before disconnecting the hoses can relieve this pressure. Modern tractor can retain significant pressure in the hydraulic lines and contain this pressure once the lines have been disconnected. Before disconnecting folding cylinder hydraulic hoses, relieve pressure from the wing-fold hydraulic system by moving the tractor control valve to the float position while the engine is running.**

**It is critical to relieve the pressure on all wing fold circuits before storing the unit. Failure to do so may allow the wings to extend or unfold unexpectedly.**

# TWIN SPRING SHANK ASSEMBLY

TWING SPING  
SHANK HOLDER ASSEMBLY  
(240560)

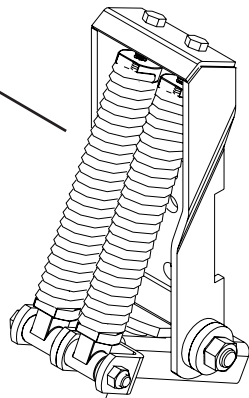

TWIN SPRING SHANK  
(55655)

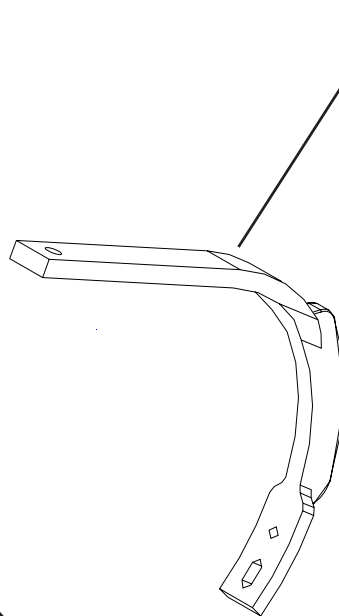

BOLT 5/8x1-3/4  
(88838)



5/8 LOCK WASHER  
(88129)



700419

# SINGLE SPRING SHANK ASSEMBLY

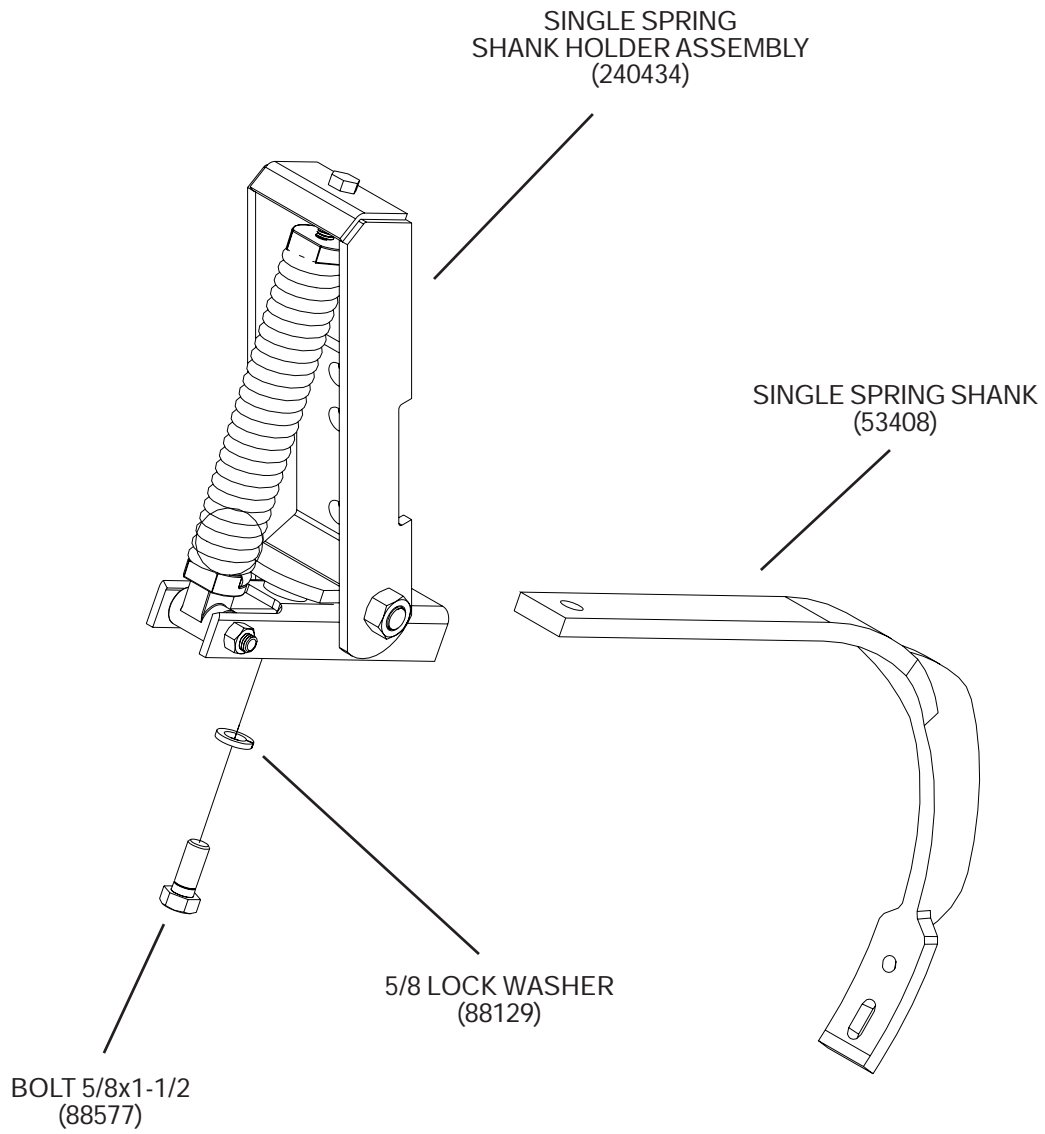

700420

# 13' MAIN FRAME

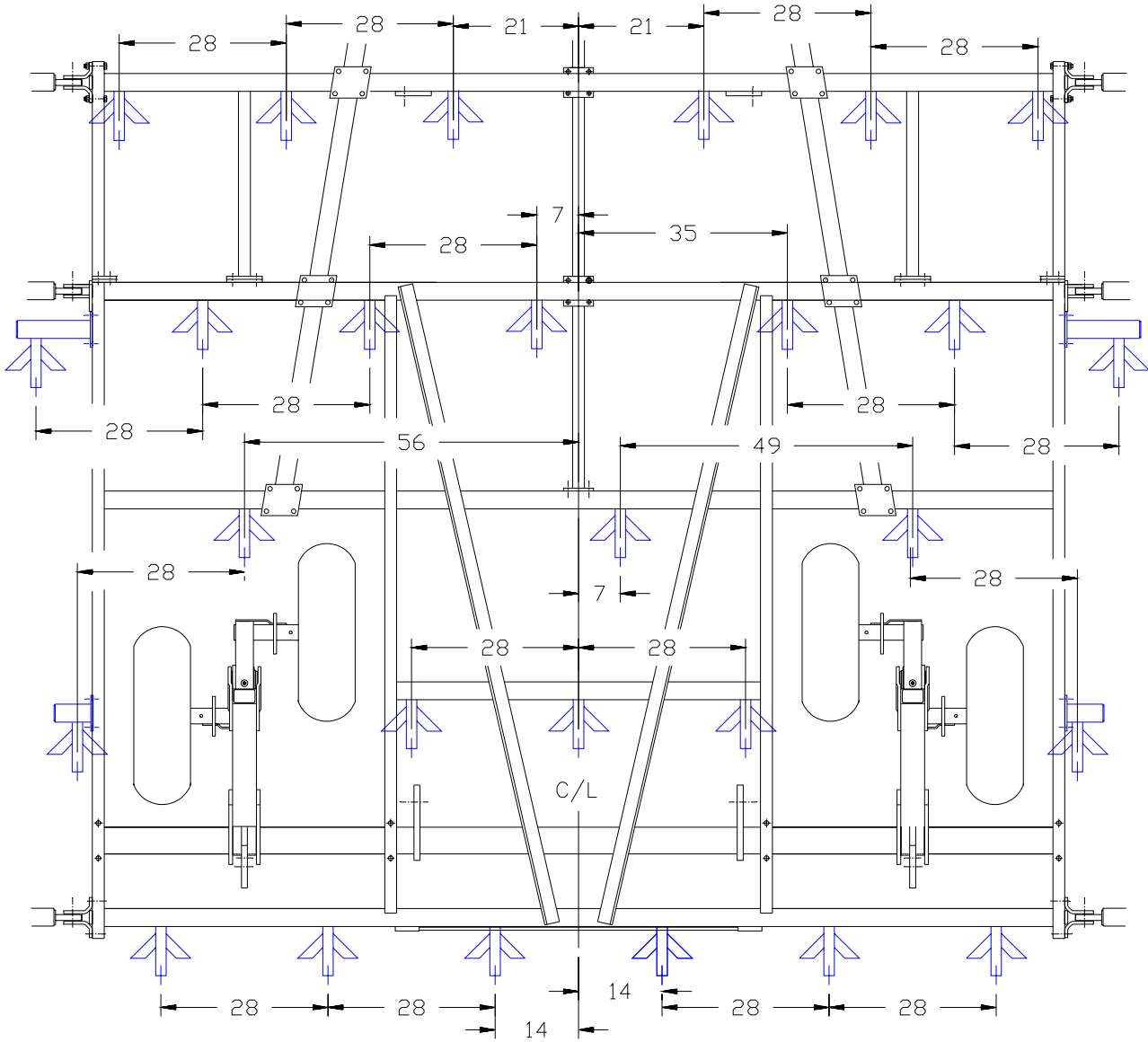

79115-13.PLT



# 11'8" WING

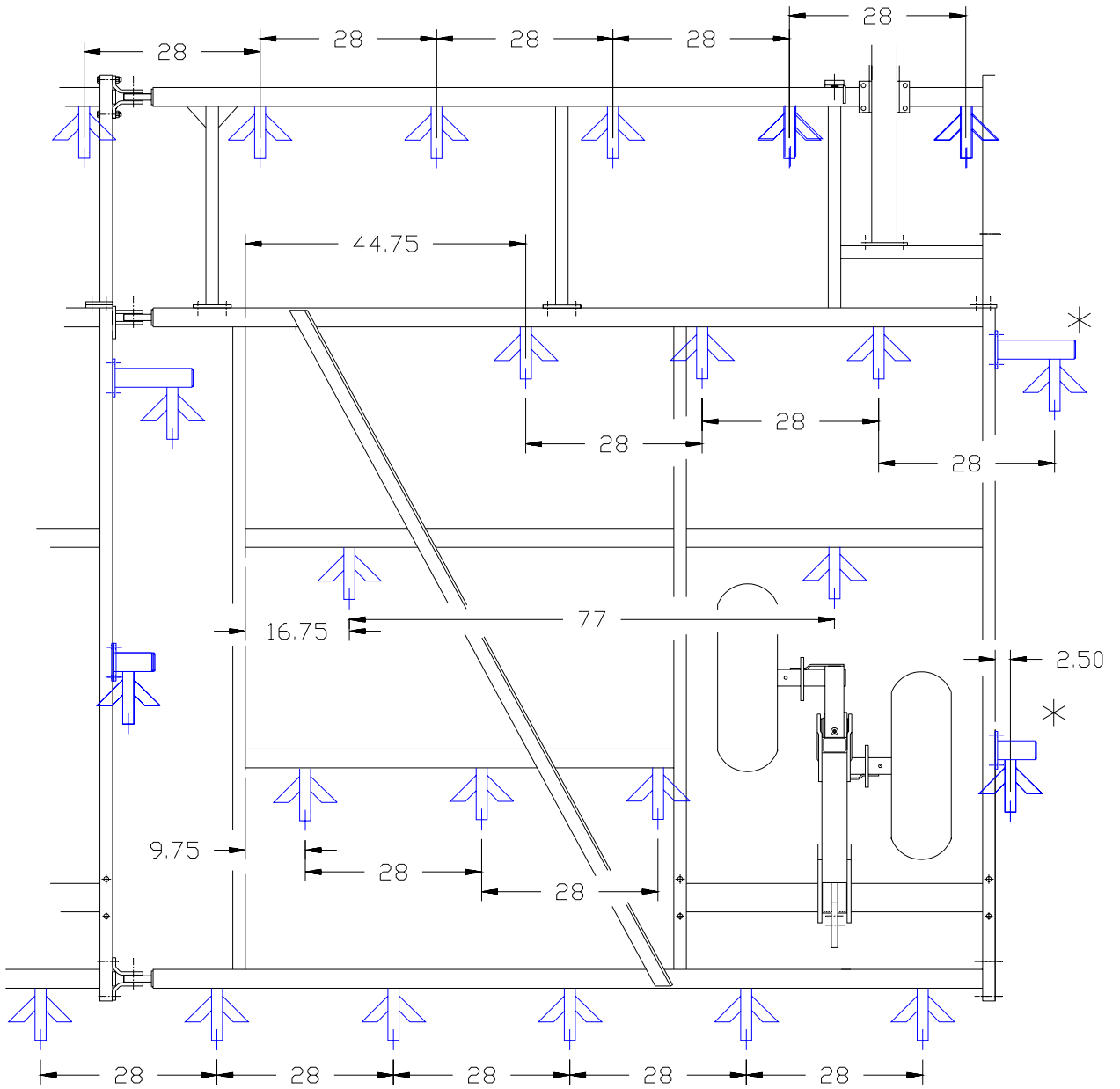

(\* ) SHANKS NOT IN BASE WING

79115W11.PLT

# 9'4" INNER WING

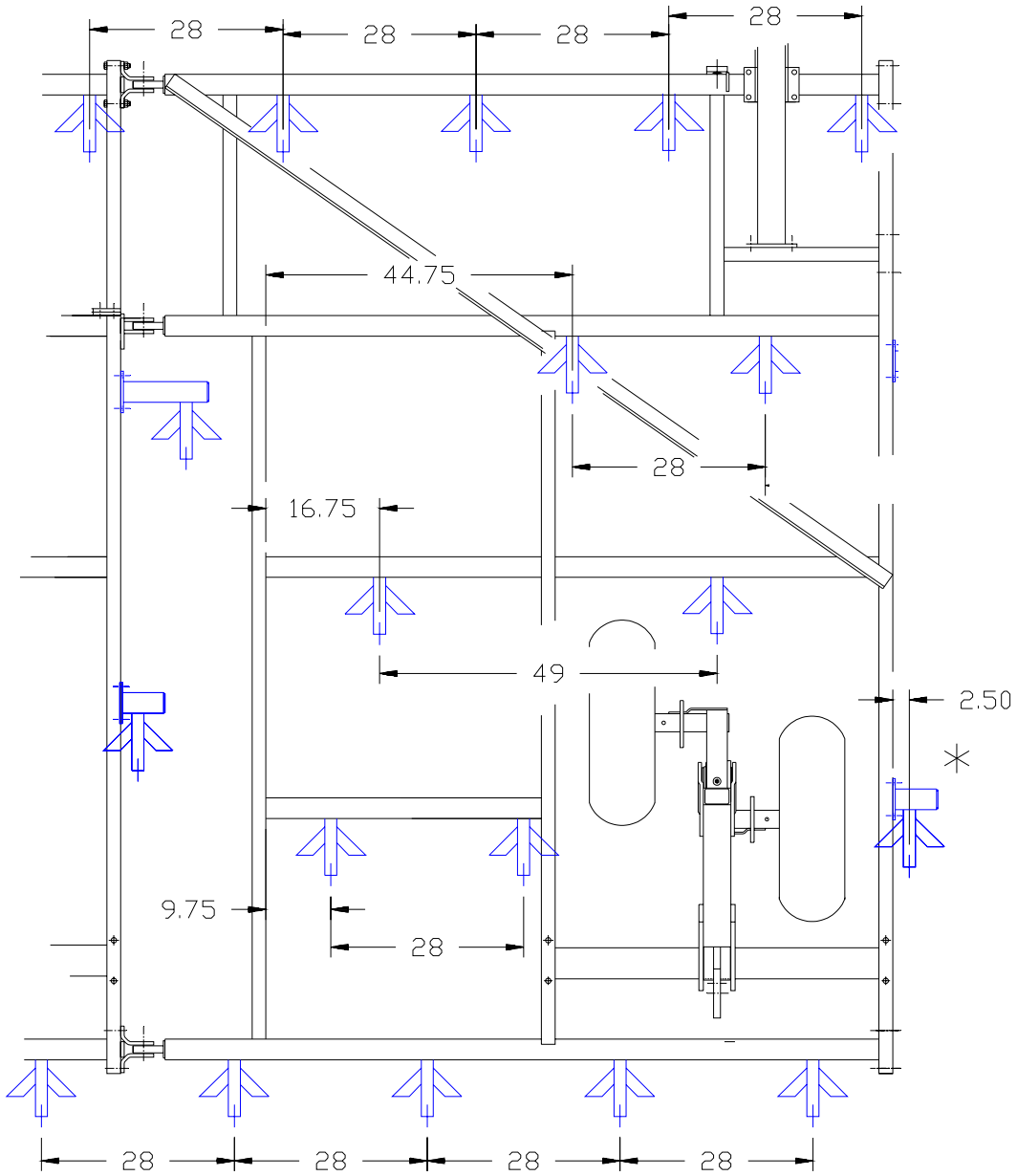

79115-9.PLT

# 9'4" OUTER WING

\* = DENOTES ADD-ON SHANKS, NOT INCLUDED WITH BASE WING

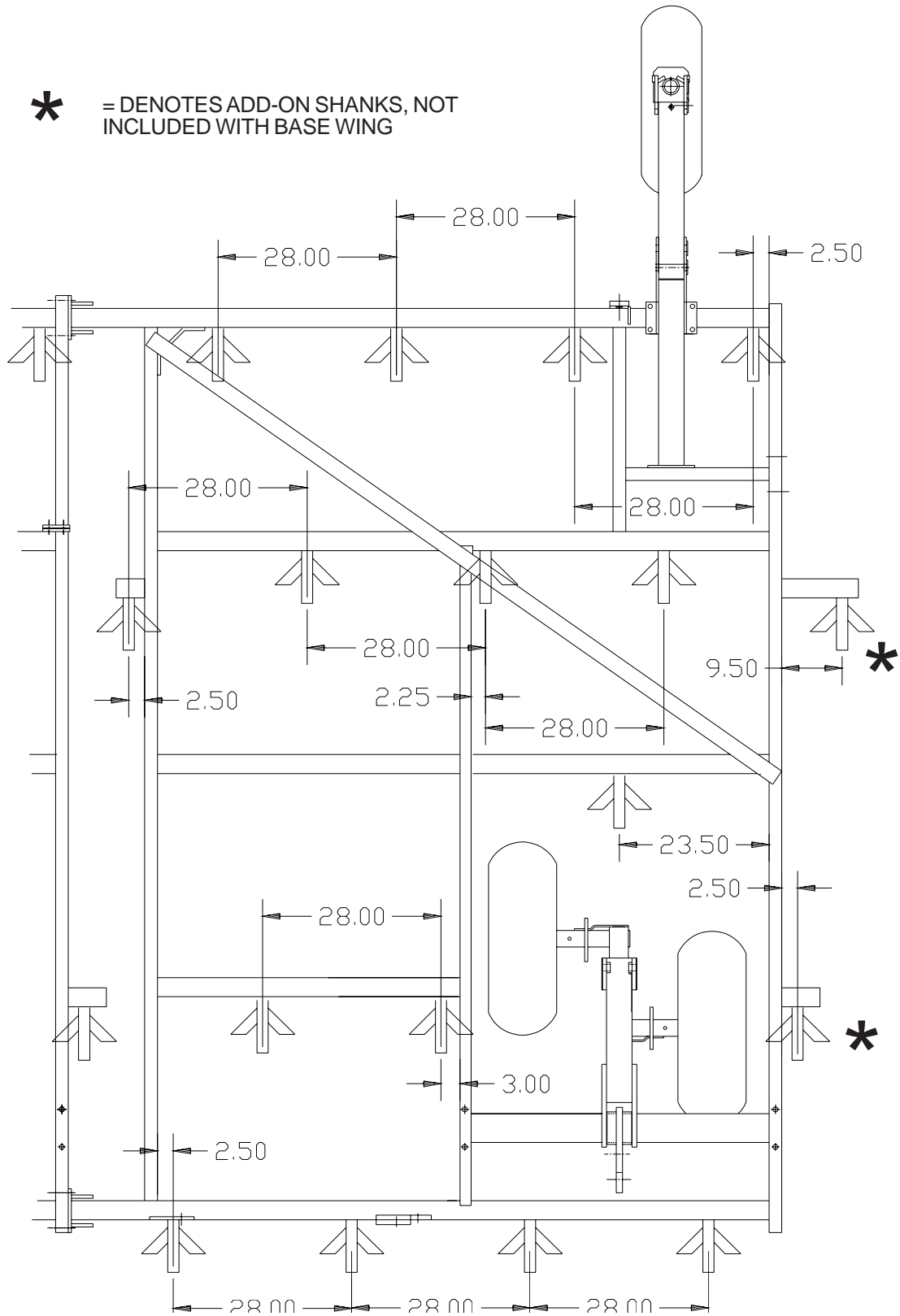

94OWSHANK

# 7' OUTER WING

\* = DENOTES ADD-ON SHANKS, NOT INCLUDED WITH BASE WING

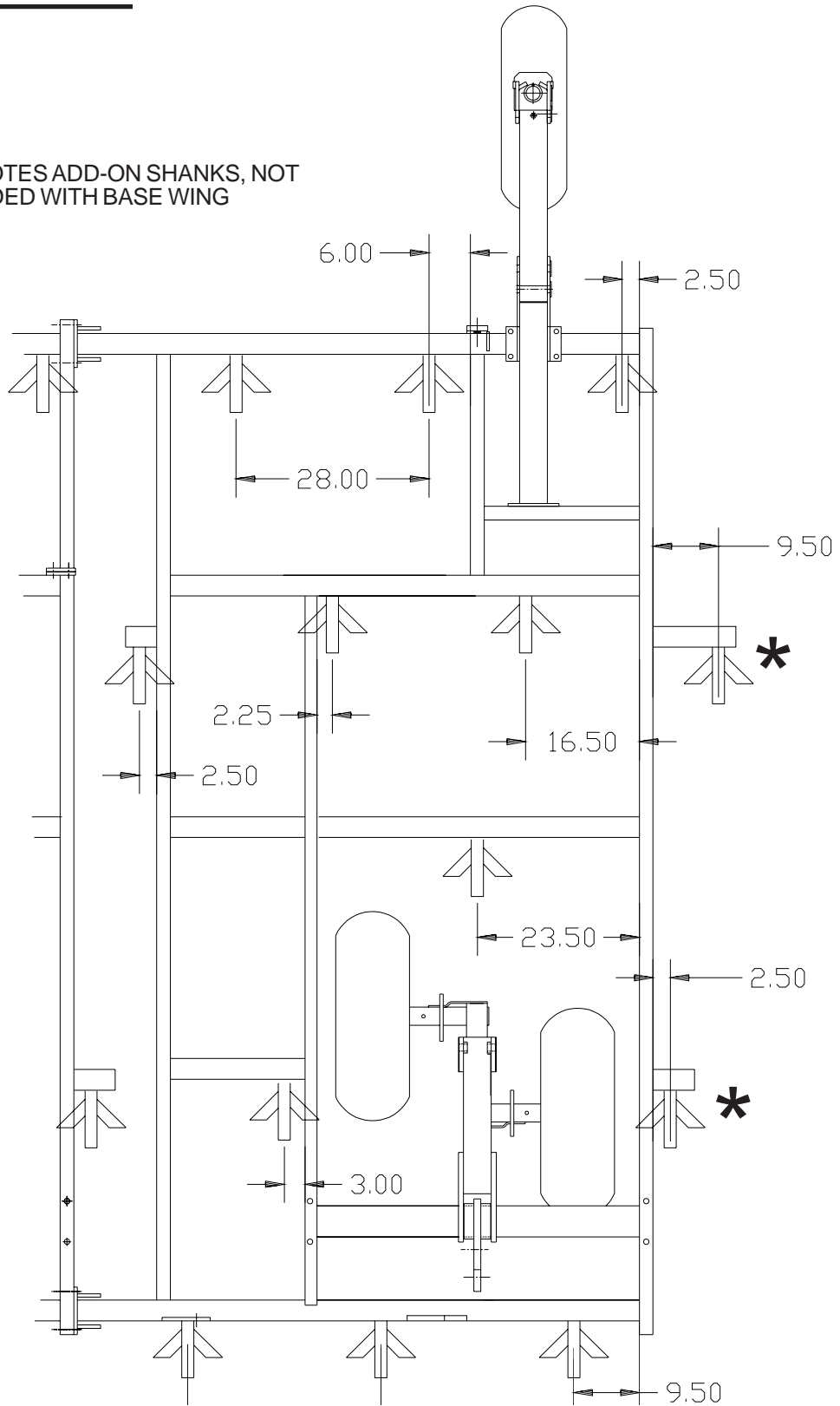

TOWSHANK

# HD AUXILIARY HITCH

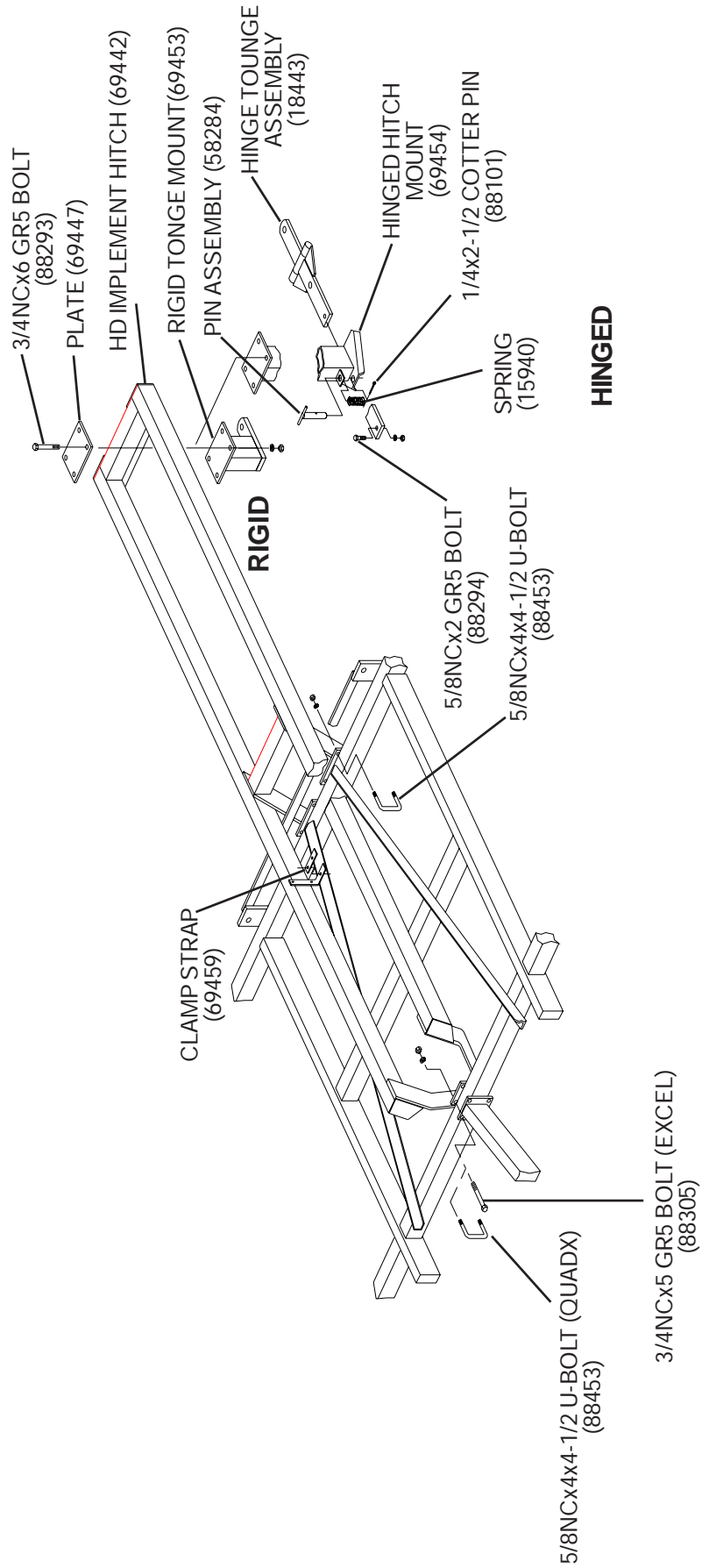

# SAFETY DECAL PLACEMENT

**NOTE:**

Thoroughly clean areas where decals are to be applied before applying decals to assure proper adhesion.

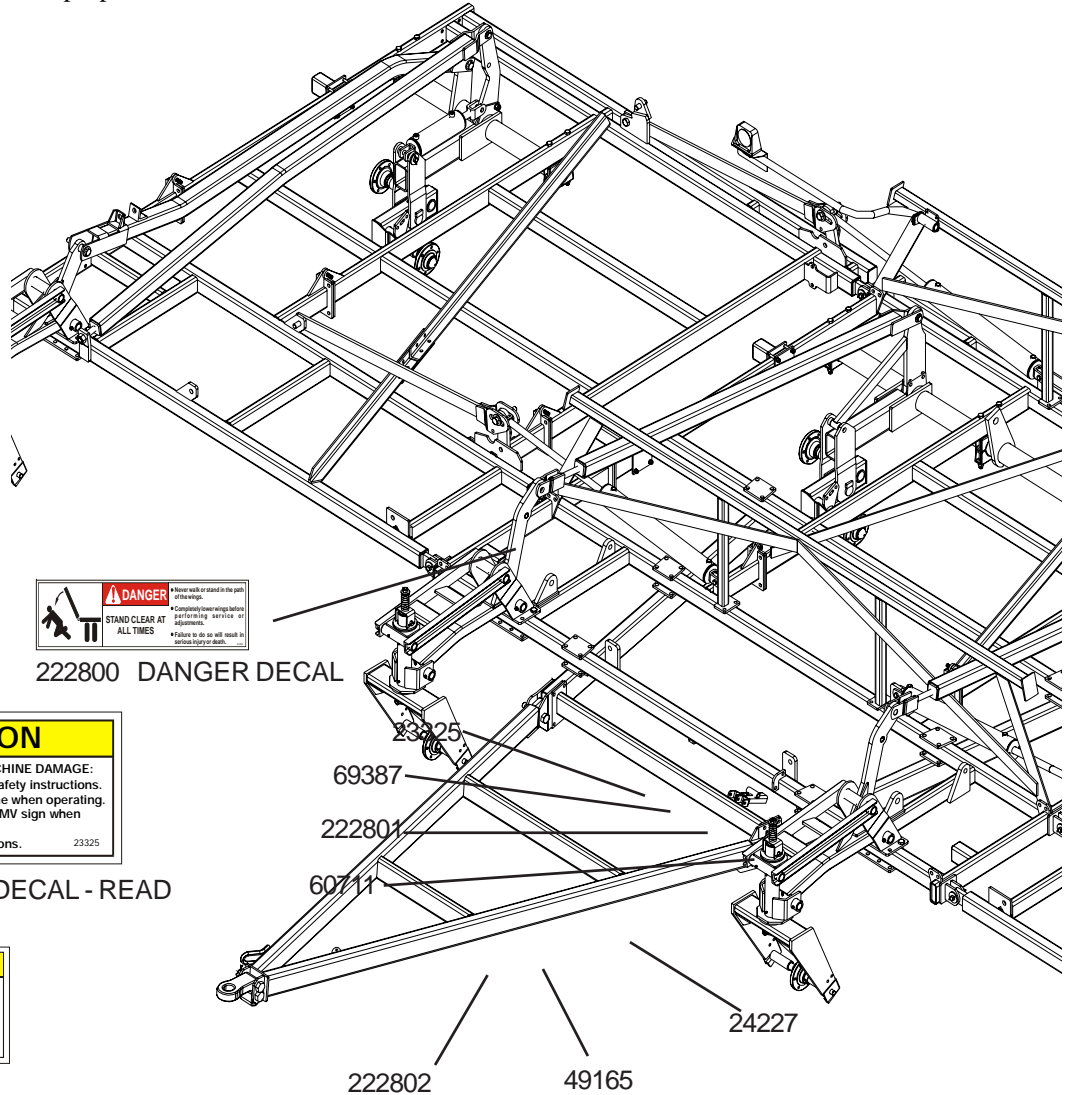

222800 DANGER DECAL

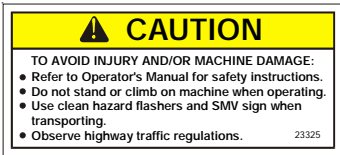

23325 CAUTION DECAL - READ

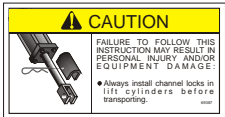

69387 WARNING DECAL-OPERATING

WINGS UP	WINGS DOWN	MAIN UP	MAIN DOWN
WINGS UP	WINGS DOWN	MAIN UP	MAIN DOWN
WINGS UP	WINGS DOWN	MAIN UP	MAIN DOWN
WINGS UP	WINGS DOWN	MAIN UP	MAIN DOWN
WINGS UP	WINGS DOWN	MAIN UP	MAIN DOWN
WINGS UP	WINGS DOWN	MAIN UP	MAIN DOWN

- 54900 WINGS UP DECAL
- 54901 WINGS DOWN DECAL
- 54902 MAIN UP DECAL
- 54903 MAIN DOWN DECAL

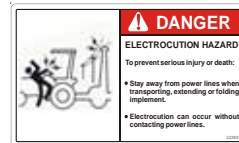

222801 ELECTROCUTION DECAL

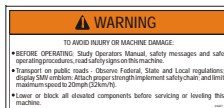

24227 WARNING DECAL-OPERATING

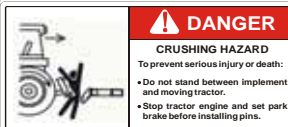

222802 CRUSHING DECAL

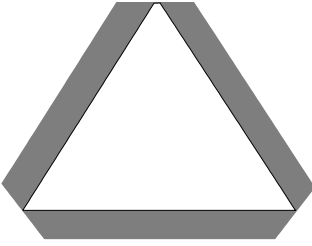

41345 SMV KIT

	<b>DANGER</b> STAND CLEAR AT ALL TIMES.	• Never walk or stand in the path of the wings.	• Completely lower the wings before performing service or adjustments.	• Failure to do so will result in serious injury or death.	ASSEMBLE SO DECAL IS READ FROM THE IMPLEMENT REAR.
		<b>41508 WING LOCK DANGER DECAL</b>			

41508 WING LOCK DANGER DECAL

	<b>CAUTION</b> FAILURE TO FOLLOW THESE INSTRUCTIONS MAY RESULT IN PERSONAL INJURY AND/OR EQUIPMENT DAMAGE.	• Just before and during operation be sure no one is on or around the implement.	• Before activating the hydraulic system, check hoses for proper connections.	• Before lowering the wings for the first time, make sure the entire system has been charged with oil.	• With wings down always install hydraulic cylinder channel lock(s) for transporting.
		<b>53334 CAUTION DECAL</b>			

53334 CAUTION DECAL

	<b>CAUTION</b> TO AVOID INJURY AND/OR EQUIPMENT DAMAGE:

20121 INTEGRAL RESTRICTOR DECAL

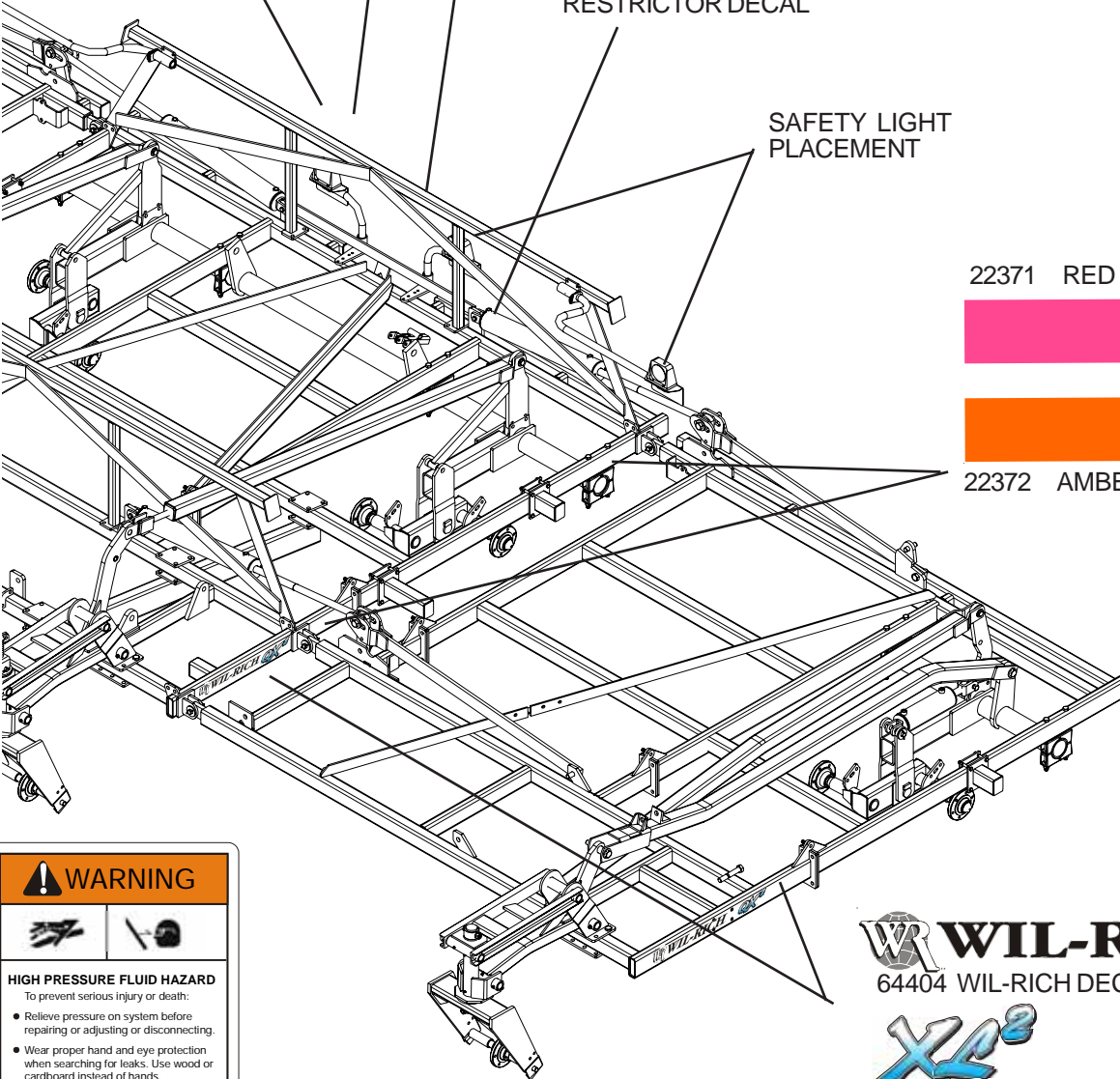

SAFETY LIGHT PLACEMENT

22371 RED DEFLECTOR



22372 AMBER DEFLECTOR

	<b>WARNING</b>
<b>HIGH PRESSURE FLUID HAZARD</b> To prevent serious injury or death:	
<ul style="list-style-type: none"> <li>• Relieve pressure on system before repairing or adjusting or disconnecting.</li> <li>• Wear proper hand and eye protection when searching for leaks. Use wood or cardboard instead of hands.</li> <li>• Keep all components in good repair. 60711</li> </ul>	

60711 HIGH PRESSURE FLUID HAZARD



64404 WIL-RICH DECAL



242816 XL² DECAL

	<b>CAUTION</b> FAILURE TO FOLLOW THESE INSTRUCTIONS MAY RESULT IN PERSONAL INJURY AND/OR EQUIPMENT DAMAGE.	• Just before and during operation be sure no one is on or around the implement.	• Before lowering the wings for the first time, make sure the entire system has been charged with oil.
		• Before activating the hydraulic system, check hoses for proper connections.	• With wings down always install hydraulic cylinder channel lock(s) for transporting.

49165 CAUTION DECAL

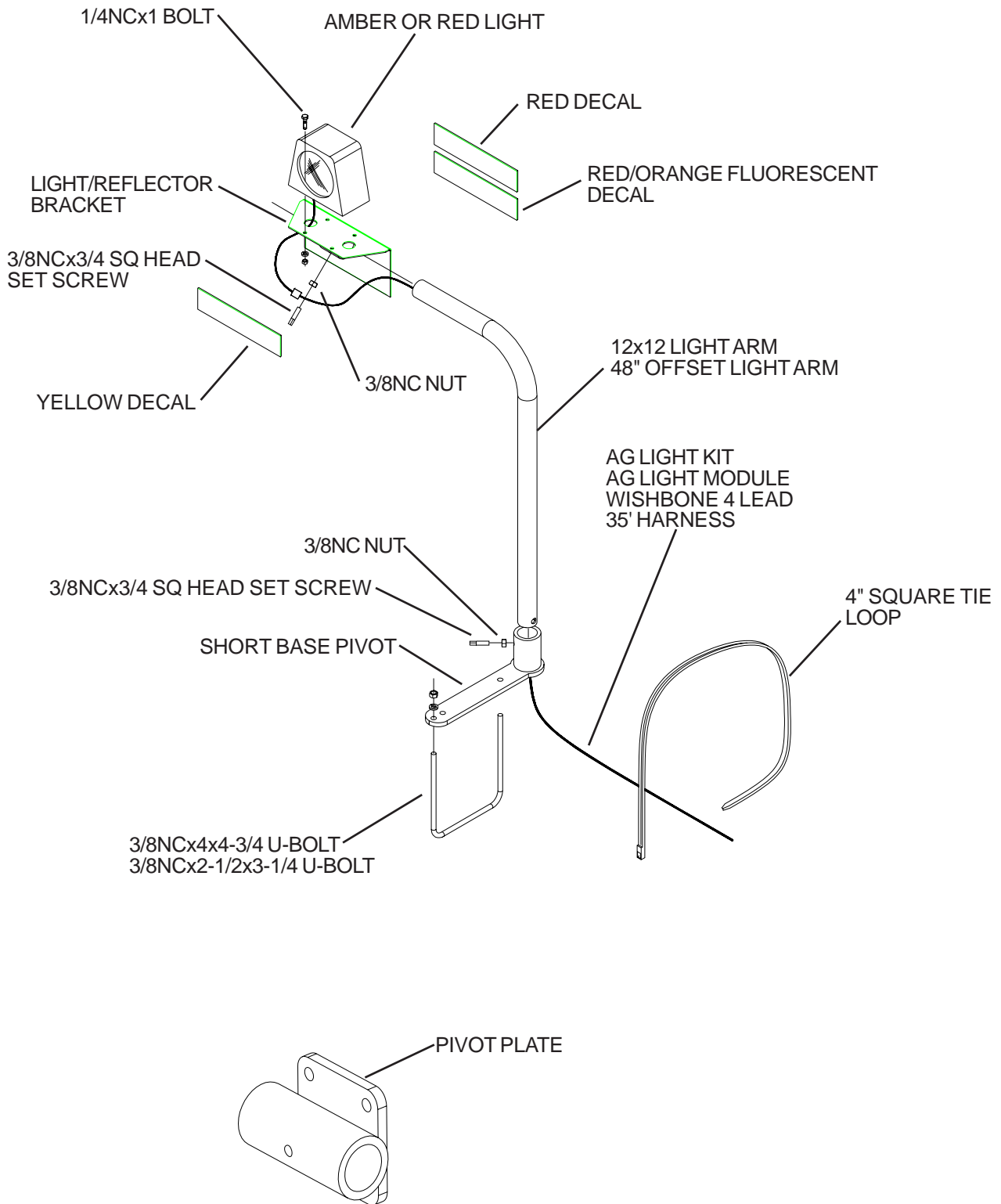



## NOTES