



ASSEMBLY, ADJUSTMENT & PARTS

MOUNTED HEAVY DUTY COIL TINE HARROW

FOR 614NT SERIES DISCS

AND 800NT SERIES DISCS



PO Box 1030
Wahpeton, ND 58074
PH (701) 642-2621
Fax (701) 642-3372

PERSONAL SAFETY IS IMPORTANT!

ALL PERSONNEL INVOLVED WITH THE ASSEMBLY AND/OR OPERATION OF THIS EQUIPMENT MUST BE INFORMED OF PROPER SAFETY PROCEDURES. OPERATOR'S AND ASSEMBLY MANUALS PROVIDE THE NECESSARY INFORMATION. IF THE MANUAL IS LOST FOR A PARTICULAR IMPLEMENT, ORDER A REPLACEMENT AT ONCE. OPERATOR'S AND ASSEMBLY MANUALS ARE AVAILABLE AT NO CHARGE UPON REQUEST.

ADDRESS INQUIRIES TO:

WIL-RICH

PO BOX 1030

WAHPETON, ND 58074

PH (701)642-2621 FAX (701)642-3372

ASSEMBLY INFORMATION

Remove all wires and arrange the parts conveniently.

NOTE: Always wear safety glasses or goggles and be careful when cutting wires and steel bands as they are under tension and will spring back when cut.

Wherever the terms "left" and "right" are used, it must be understood to mean from a position behind and facing the machine.

Lubricate all bearings and moving parts as you proceed and make sure they work freely.

Loosely install all bolts connecting mating parts before final tightening.

When tightening bolts, they must be torqued to the proper number of foot-pounds as indicated in the table unless specified. It is important that all bolts be kept tight.

On new machines, all nuts and bolts must be re-checked after a few hours of operation.

When replacing a bolt, use only a bolt of the same grade or higher. Except in shear bolt applications, where you must use the same grade bolt.

Bolts with no markings are grade 2

Grade 5 bolts furnished with the machine are identified by three radial lines on the head.

Grade 8 bolts furnished with the machine are identified by six radial lines on the head.

All U-bolts are grade 5.



THIS SYMBOL USED TO CALL YOUR ATTENTION TO INSTRUCTIONS CONCERNING YOUR PERSONAL SAFETY.

BE SURE TO OBSERVE AND FOLLOW THESE INSTRUCTIONS

		GRADE 2			GRADE 5			GRADE 8		
TORQUE IN FOOT POUNDS										
BOLT DIA		3/8	1/2	5/8	3/4	7/8	1			
HEX HEAD		9/16	3/4	15/16	1-1/8	1-5/16	1-1/2			
UNC	GR2	18	45	89	160	252	320			
UNC	GR5	30	68	140	240	360	544			
UNC	GR8	40	100	196	340	528	792			
UNF	GR2	21	51	102	178	272	368			
UNF	GR5	32	70	168	264	392	572			
UNF	GR8	48	112	216	368	792	840			

CAUTION

TO AVOID INJURY AND/OR MACHINE DAMAGE:

- Refer to Operator's Manual for safety instructions.
- Do not stand or climb on machine when operating.
- Use clean hazard flashers and SMV sign when transporting.
- Observe highway traffic regulations.

23325

CAUTION

Failure to follow these instructions may result in personal injury and/or equipment damage.

- Just before and during operation be sure no one is on or around the implement.
- Before activating the hydraulic system, check hoses for proper connections.
- Before lowering the wings for the first time, make sure the entire system has been charged with oil.
- With wings down always install hydraulic cylinder channel lock(s) for transporting.

54374

HARROW OPERATION

SECTION LEVEL ADJUSTMENT

To set the harrow working depth, first set the disc to its working position. Remove the 5/8NCx5 GR5 bolt and relocate as required. The section should be set to run 3" to 5" deep in the working position.

DEPTH ADJUSTMENT BOLT

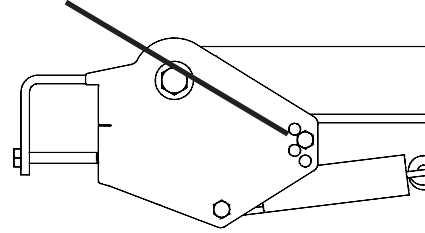

PIVOT BRACKET

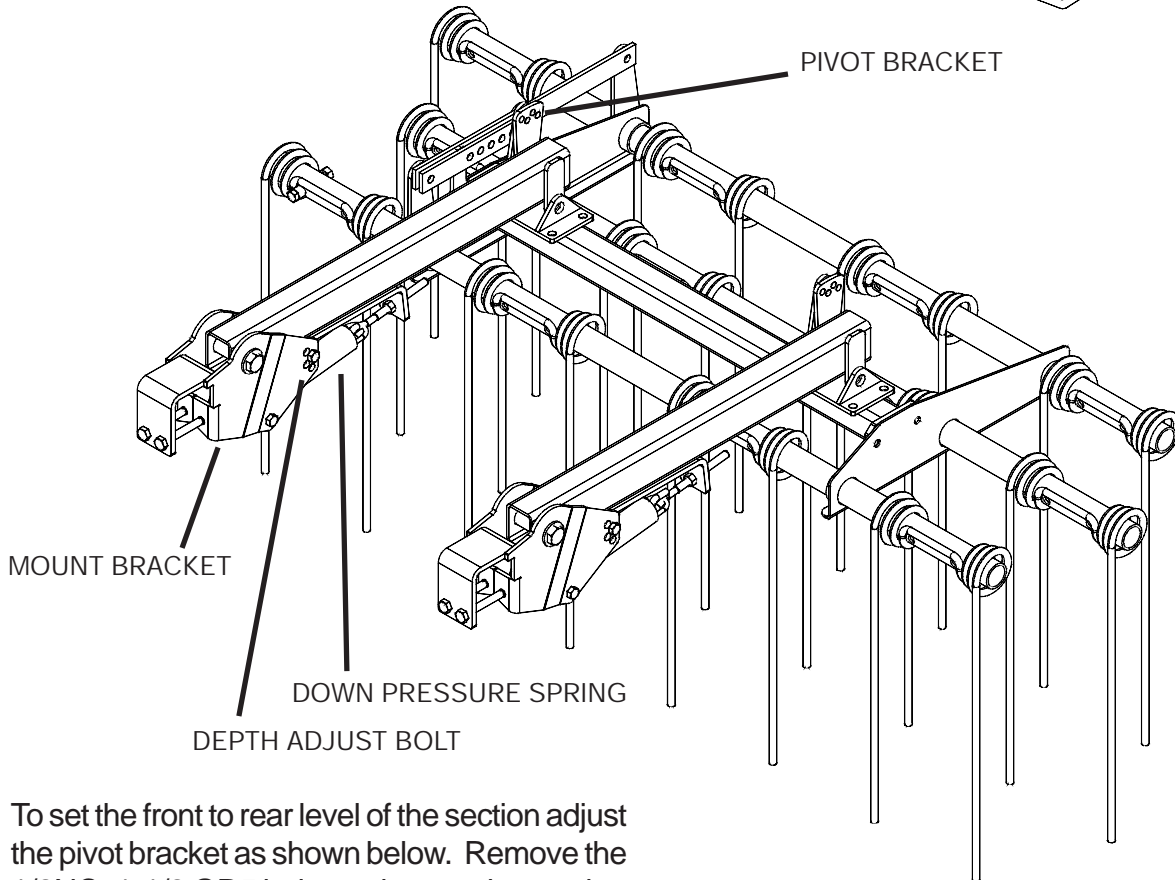

To set the front to rear level of the section adjust the pivot bracket as shown below. Remove the 1/2NCx1-1/2 GR5 bolts and rotate the section until the section is level. Reinstall bolts and tighten to specified torque.

1/2NCx1-1/2 GR5 BOLT

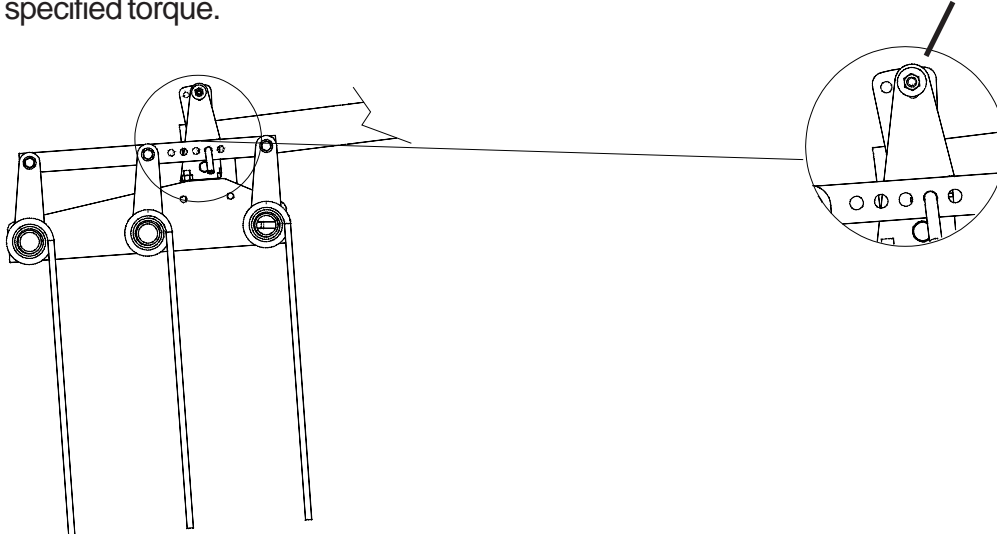

HARROW ARM/PIVOT BRACKET ASSEMBLY

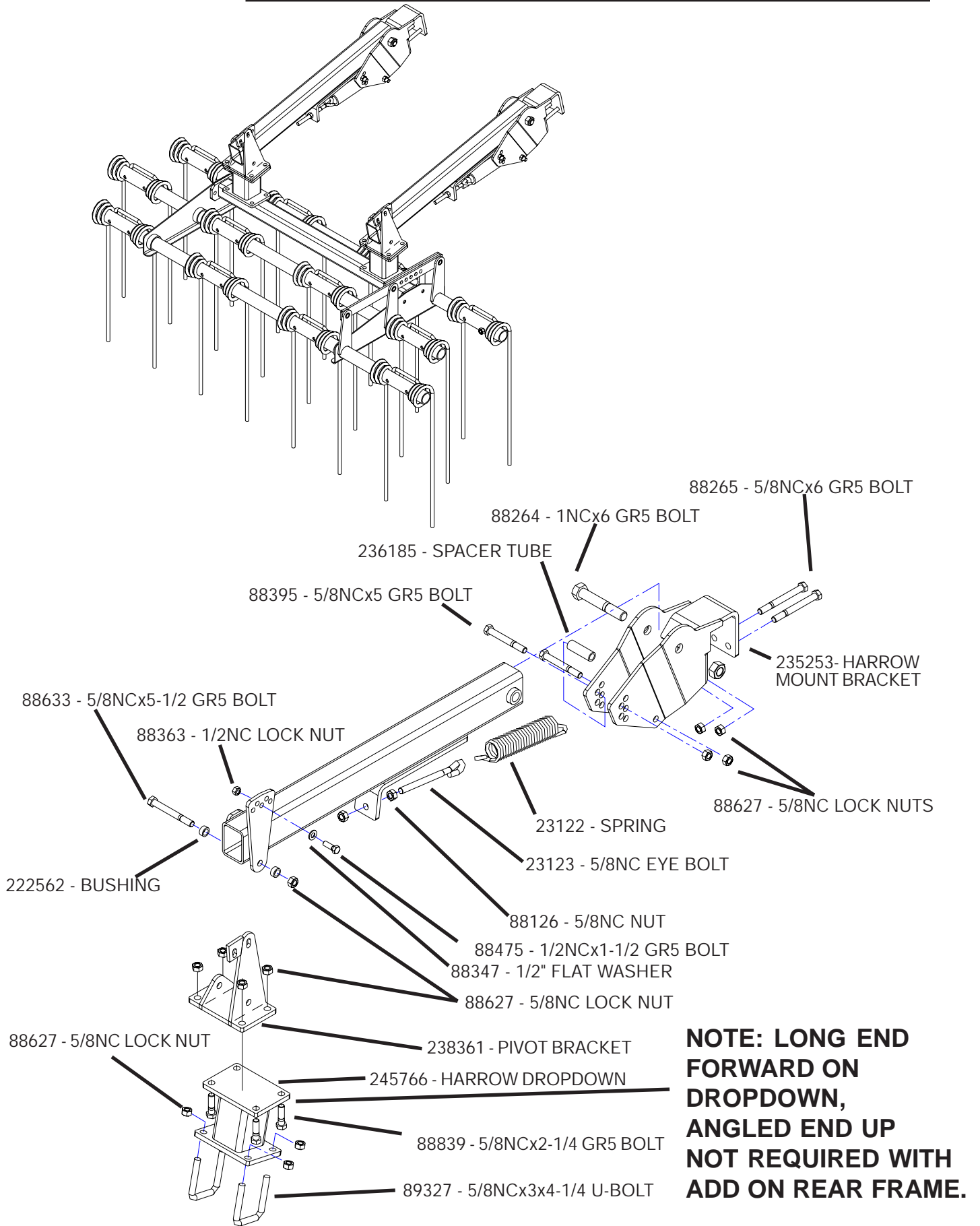

HARROW SECTION ASSEMBLY

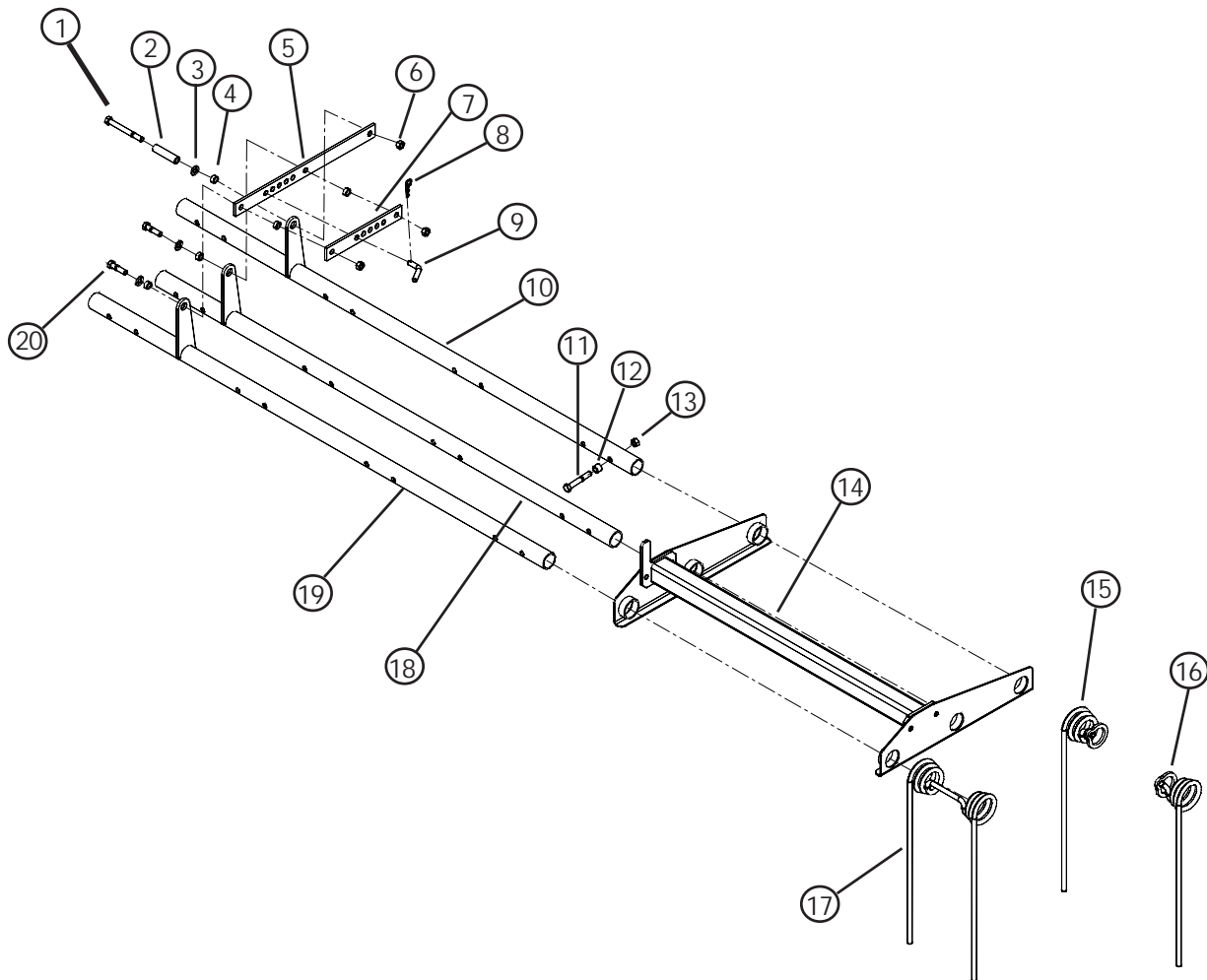

ITEM	PART NO.	DESCRIPTION	ITEM	PART NO.	DESCRIPTION
1	88295	5/8NCx6 GR5 BOLT	15	236021	QTY 3/ 4FT SEC. R SINGLE HARROW TOOTH
2	22521	SPACER TUBE	16	236020	QTY 3/ 4FT SEC. L SINGLE HARROW TOOTH
3	88277	5/8 FLAT WASHER	17	236087	SHORT H.D. HARROW TOOTH
4	222562	BUSHING			QTY - 12/ 8FT SEC
5	222570	ADJUST BAR			9/ 6FT SEC
6	88627	5/8NC LOCK NUT			3/ 4FT SEC
7	222575	INNER ADJUST BAR	18	222573	8FT CENTER HARROW TUBE
8	23039	HAIR PIN		222568	6FT CENTER HARROW TUBE
9	32871	5/8x1-3/8 BENT PIN		236026	4FT CENTER HARROW TUBE
10	222574	8FT REAR HARROW TUBE	19	222572	8FT FRONT HARROW TUBE
	222569	6FT REAR HARROW TUBE		222567	6FT FRONT HARROW TUBE
	236027	4FT REAR HARROW TUBE		236024	4FT FRONT HARROW TUBE
11	88298	5/8NCx4 GR5 BOLT	20	88409	5/8NCx2-1/2 GR5 BOLT
		QTY - 24-8FT			
		18-6FT			
		12-4FT			
12	200479	BUSHING			
13	88845	5/8NC LOCK NUT			
14	236195	8FT HARROW MOUNT WELD			
	236198	6FT HARROW MOUNT WELD			
	236028	4FT HARROW MOUNT WELD			

INTERMEDIATE TUBE ASSEMBLY

NOTE: THIS IS FOR GENERAL ASSEMBLY INSTRUCTIONS. HARROWS CAN HAVE DIFFERENT SECTION ARANGMENTS.

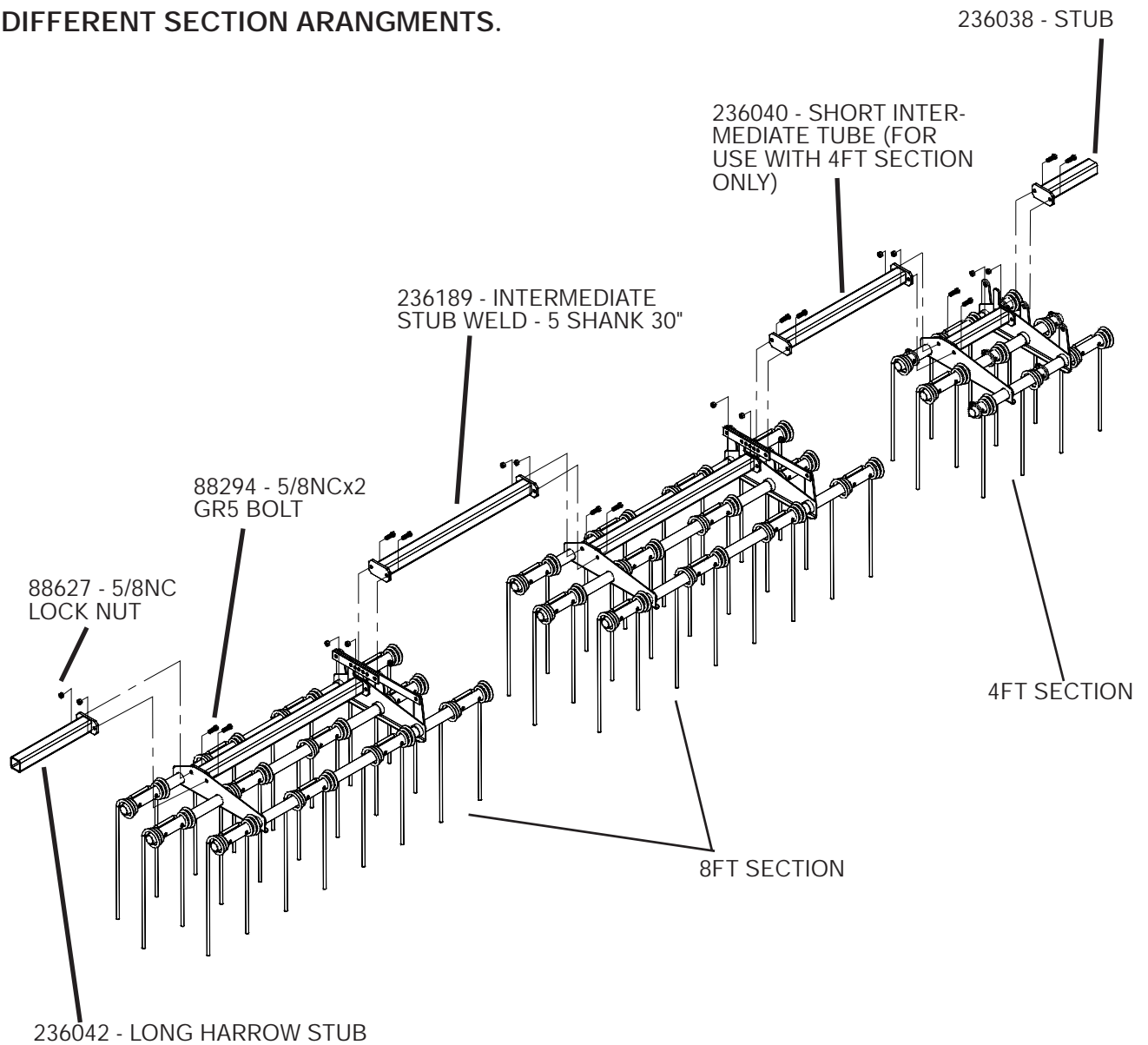

SINGLE HARROW ARM SUPPORT ASSEMBLY

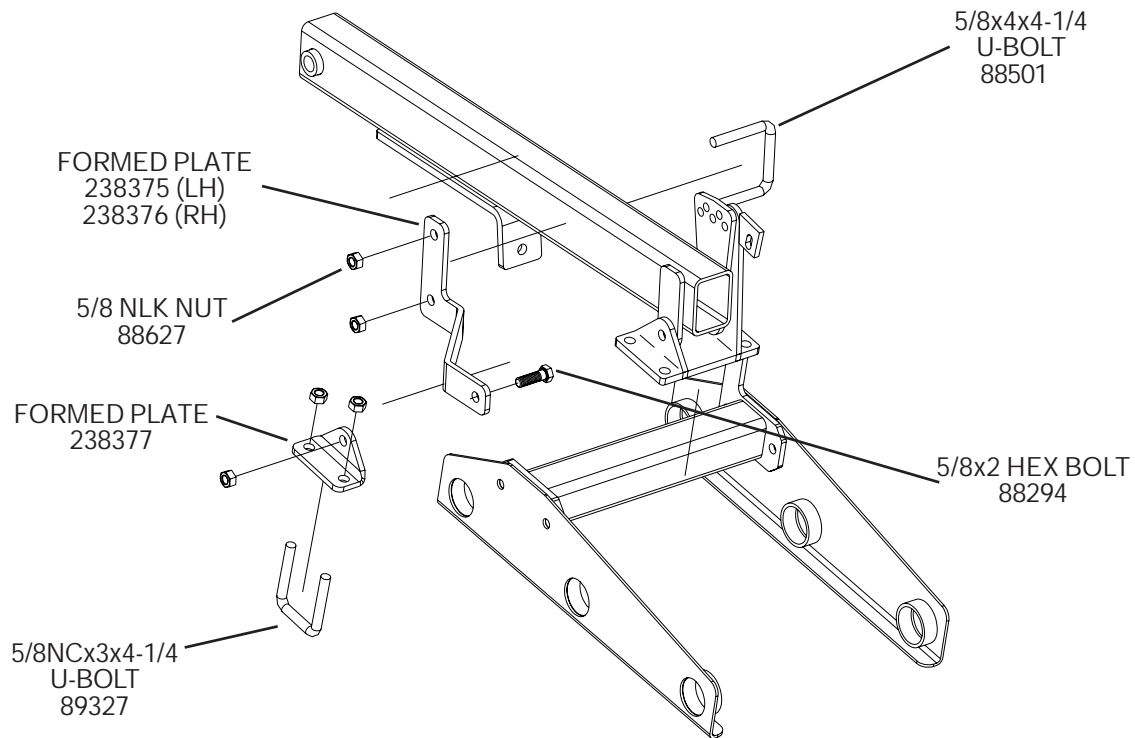

700158

THIS KIT IS DESIGNED TO BE USED ON HARROW SECTION THAT ARE SUPPORTED WITH ONE ARM. USUALLY THEY ARE 4FT SECTION ON OUTER WINGS OF MACHINES

HARROW STOP ARM ASSEMBLY

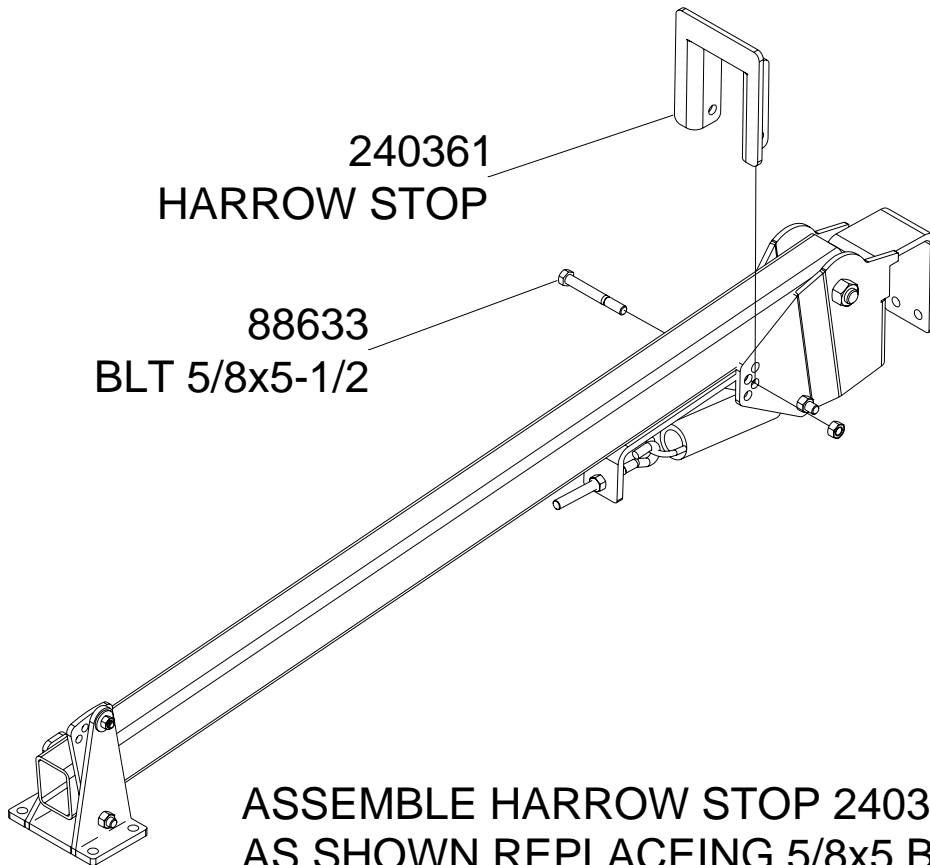

ASSEMBLE HARROW STOP 240361
AS SHOWN REPLACEING 5/8x5 BOLT
WITH BOLT SUPPLIED. THIS SHOULD BE
DONE ON OUTER WINGS TO PREVENT
HARROW DAMAGE.

BOLT-ON FRAME EXTENSION

BOLT-ON FRAME EXTENSION
8IN - (LH) 241916
(RH) 241917

16IN - (LH) 241924
(RH) 241925

30IN - (LH) 241931
(RH) 241932

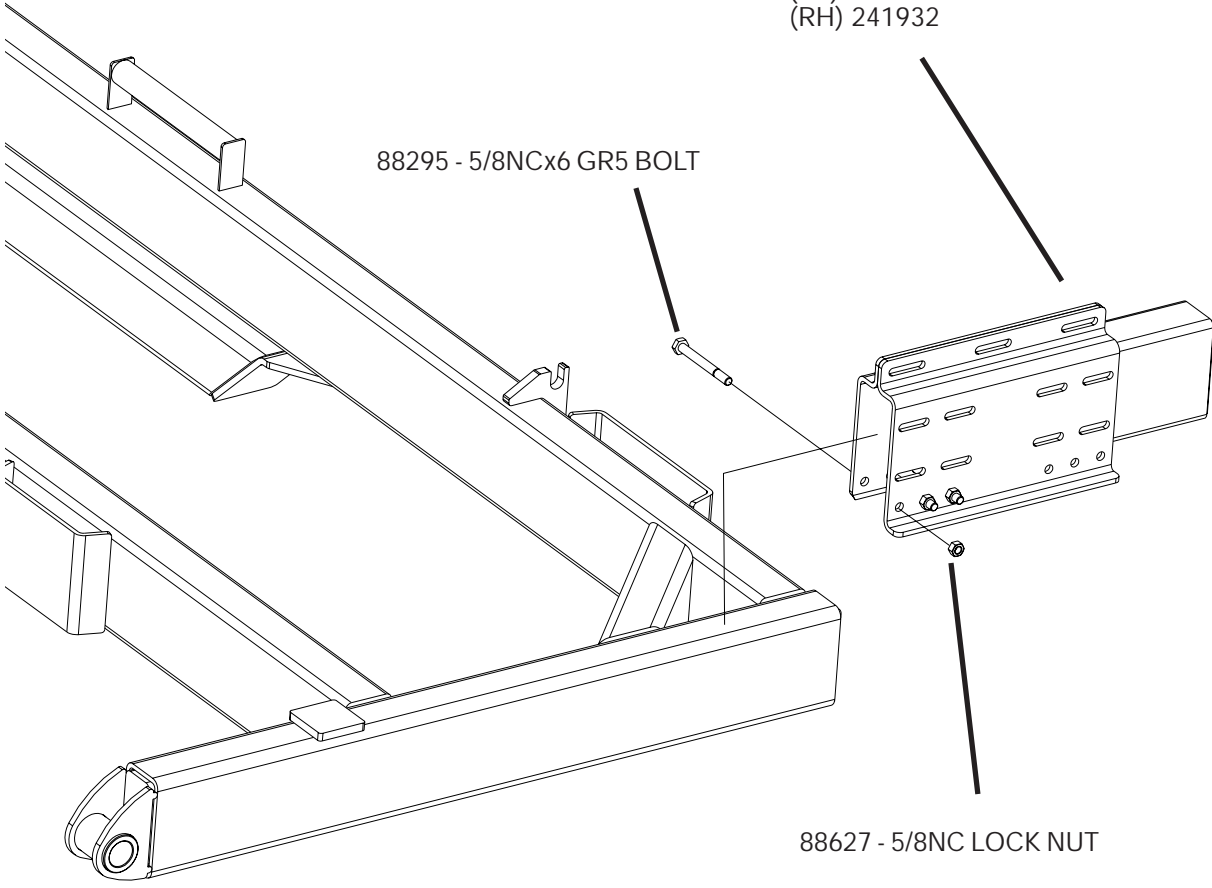

ADD-ON REAR FRAME- 800NT

**NOTE: BOLT ON FRAME
EXTENSION NOT REQUIRED
WITH ADD-ON REAR FRAME**

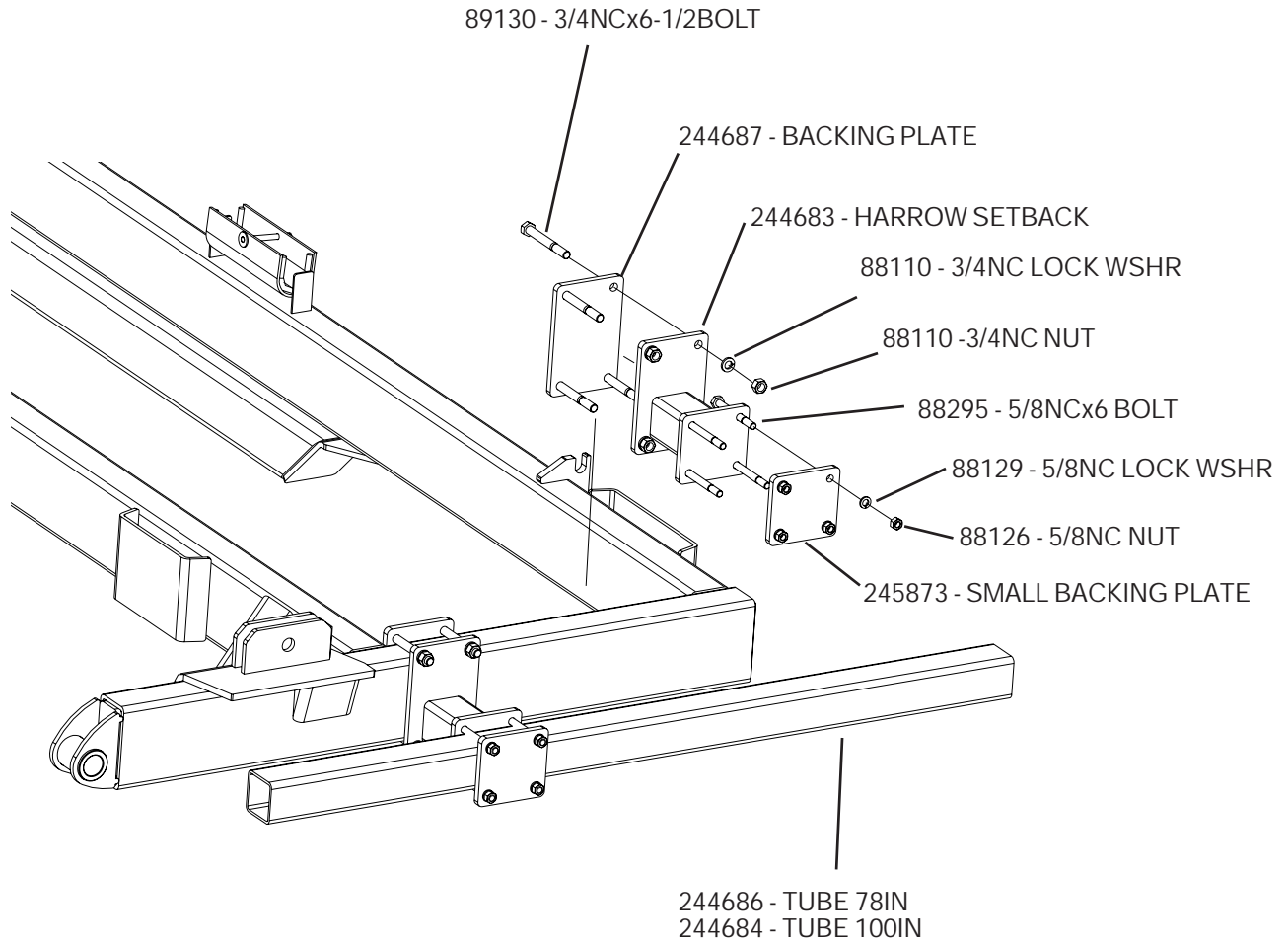

ADD-ON REAR FRAME - 614NT

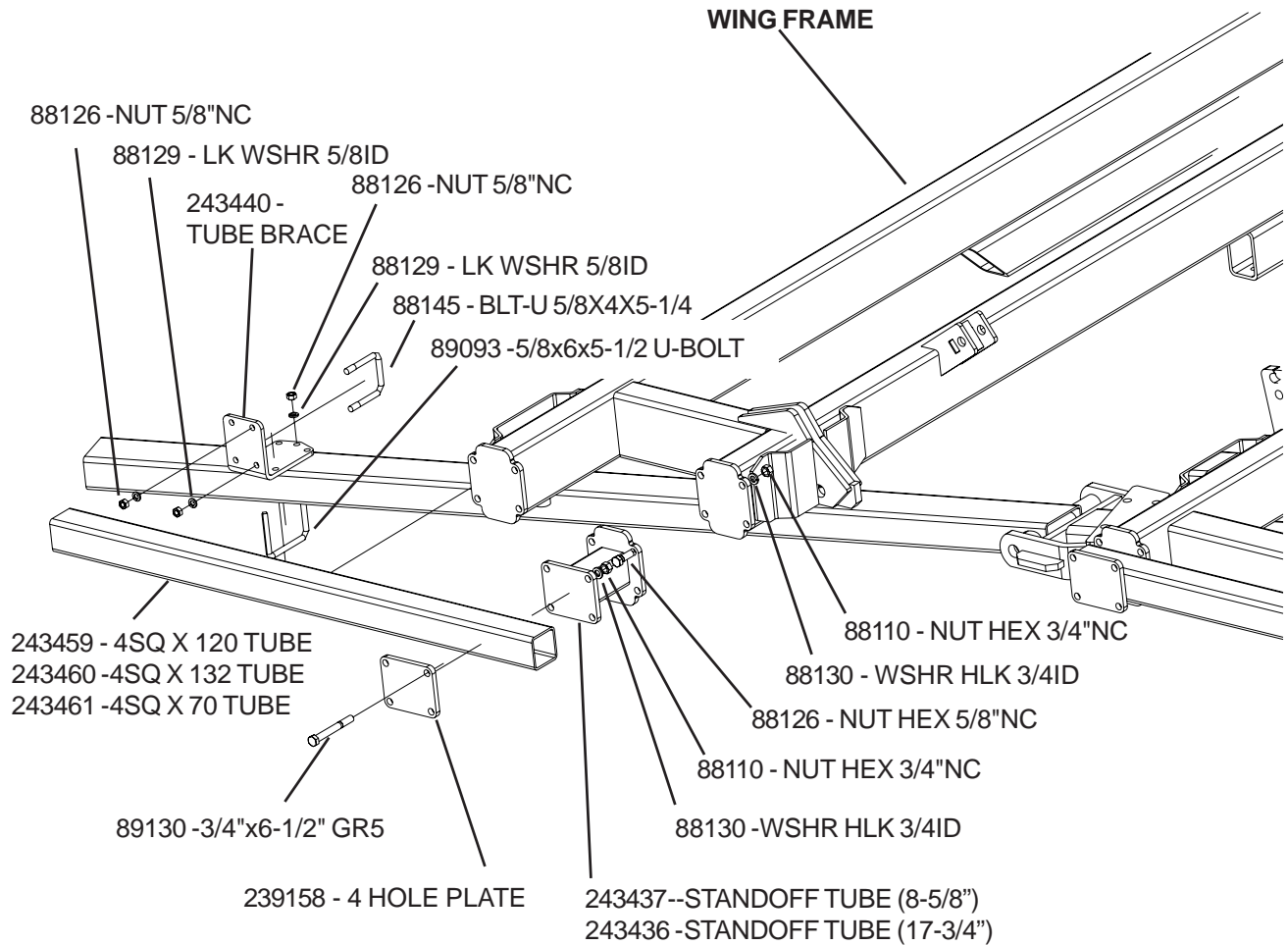

NOTE: CENTER SECTION DOES NOT GET STANDOFF TUBES. CENTER SECTIONS WILL SIT FORWARD OF WING SECTIONS

614NT SERIES DISC HARROW MOUNTING CHART

x		x	APPROX ARM LOCATION (IN FROM CENTER) SECTION, STUBS, SPANNERS & EXT
x	x	x	

DISC MODEL	WINGS	MAIN FRAME	WINGS																											
14 disc		<table border="1" style="margin: auto;"> <tr><td colspan="3">158in Mnt tube</td></tr> <tr><td>8ft</td><td>46"SP</td><td>8ft</td></tr> </table>	158in Mnt tube			8ft	46"SP	8ft																						
158in Mnt tube																														
8ft	46"SP	8ft																												
16 disc		<table border="1" style="margin: auto;"> <tr><td>60</td><td>20</td><td></td><td>20</td><td>60</td></tr> <tr><td colspan="5">158in Mnt tube</td></tr> <tr><td>6ft</td><td>46"SP</td><td>6ft</td><td>46"SP</td><td>6ft</td></tr> <tr><td>60</td><td>20</td><td></td><td>20</td><td>60</td></tr> </table>	60	20		20	60	158in Mnt tube					6ft	46"SP	6ft	46"SP	6ft	60	20		20	60								
60	20		20	60																										
158in Mnt tube																														
6ft	46"SP	6ft	46"SP	6ft																										
60	20		20	60																										
17 disc		<table border="1" style="margin: auto;"> <tr><td colspan="5">158in Mnt tube</td></tr> <tr><td>6ft</td><td>46"SP</td><td>6ft</td><td>46"SP</td><td>6ft</td></tr> <tr><td>72</td><td>29</td><td></td><td>29</td><td>72</td></tr> </table>	158in Mnt tube					6ft	46"SP	6ft	46"SP	6ft	72	29		29	72													
158in Mnt tube																														
6ft	46"SP	6ft	46"SP	6ft																										
72	29		29	72																										
20 disc		<table border="1" style="margin: auto;"> <tr><td colspan="5">230in Mnt tube</td></tr> <tr><td>8ft</td><td>46"SP</td><td>6ft</td><td>46"SP</td><td>8ft</td></tr> <tr><td>72</td><td>29</td><td></td><td>29</td><td>72</td></tr> </table>	230in Mnt tube					8ft	46"SP	6ft	46"SP	8ft	72	29		29	72													
230in Mnt tube																														
8ft	46"SP	6ft	46"SP	8ft																										
72	29		29	72																										
24 disc	<table border="1" style="margin: auto;"> <tr><td colspan="3">70in Mnt tube</td></tr> <tr><td></td><td>6ft</td><td></td></tr> <tr><td>140</td><td></td><td>83</td></tr> </table>	70in Mnt tube				6ft		140		83	<table border="1" style="margin: auto;"> <tr><td colspan="3">120in Mnt tube</td></tr> <tr><td>6ft</td><td>46"SP</td><td>6ft</td></tr> <tr><td>40</td><td>0</td><td>40</td></tr> </table>	120in Mnt tube			6ft	46"SP	6ft	40	0	40	<table border="1" style="margin: auto;"> <tr><td colspan="3">70in Mnt tube</td></tr> <tr><td>6ft</td><td></td><td></td></tr> <tr><td>83</td><td></td><td>140</td></tr> </table>	70in Mnt tube			6ft			83		140
70in Mnt tube																														
	6ft																													
140		83																												
120in Mnt tube																														
6ft	46"SP	6ft																												
40	0	40																												
70in Mnt tube																														
6ft																														
83		140																												
27 disc	<table border="1" style="margin: auto;"> <tr><td colspan="3">70in Mnt tube</td></tr> <tr><td></td><td>8ft</td><td></td></tr> <tr><td>140</td><td></td><td>83</td></tr> </table>	70in Mnt tube				8ft		140		83	<table border="1" style="margin: auto;"> <tr><td colspan="3">120in Mnt tube</td></tr> <tr><td>6ft</td><td>46"SP</td><td>6ft</td></tr> <tr><td>40</td><td>0</td><td>40</td></tr> </table>	120in Mnt tube			6ft	46"SP	6ft	40	0	40	<table border="1" style="margin: auto;"> <tr><td colspan="3">70in Mnt tube</td></tr> <tr><td>8ft</td><td></td><td></td></tr> <tr><td>83</td><td></td><td>140</td></tr> </table>	70in Mnt tube			8ft			83		140
70in Mnt tube																														
	8ft																													
140		83																												
120in Mnt tube																														
6ft	46"SP	6ft																												
40	0	40																												
70in Mnt tube																														
8ft																														
83		140																												
30 disc	<table border="1" style="margin: auto;"> <tr><td colspan="3">70in Mnt tube</td></tr> <tr><td></td><td>8ft</td><td></td></tr> <tr><td>150</td><td></td><td>110</td></tr> </table>	70in Mnt tube				8ft		150		110	<table border="1" style="margin: auto;"> <tr><td colspan="3">120in Mnt tube</td></tr> <tr><td>6ft</td><td>46"SP</td><td>8ft</td></tr> <tr><td>40</td><td>0</td><td>40</td></tr> </table>	120in Mnt tube			6ft	46"SP	8ft	40	0	40	<table border="1" style="margin: auto;"> <tr><td colspan="3">70in Mnt tube</td></tr> <tr><td>8ft</td><td></td><td></td></tr> <tr><td>110</td><td></td><td>150</td></tr> </table>	70in Mnt tube			8ft			110		150
70in Mnt tube																														
	8ft																													
150		110																												
120in Mnt tube																														
6ft	46"SP	8ft																												
40	0	40																												
70in Mnt tube																														
8ft																														
110		150																												
33 disc	<table border="1" style="margin: auto;"> <tr><td colspan="3">120in Mnt tube</td></tr> <tr><td>6ft</td><td>46"SP</td><td>6ft</td></tr> <tr><td>180</td><td>135</td><td>110</td></tr> </table>	120in Mnt tube			6ft	46"SP	6ft	180	135	110	<table border="1" style="margin: auto;"> <tr><td colspan="3">132in Mnt tube</td></tr> <tr><td>6ft</td><td>46"SP</td><td>6ft</td></tr> <tr><td>40</td><td>0</td><td>40</td></tr> </table>	132in Mnt tube			6ft	46"SP	6ft	40	0	40	<table border="1" style="margin: auto;"> <tr><td colspan="3">120in Mnt tube</td></tr> <tr><td>6ft</td><td>46"SP</td><td>6ft</td></tr> <tr><td>110</td><td>135</td><td>180</td></tr> </table>	120in Mnt tube			6ft	46"SP	6ft	110	135	180
120in Mnt tube																														
6ft	46"SP	6ft																												
180	135	110																												
132in Mnt tube																														
6ft	46"SP	6ft																												
40	0	40																												
120in Mnt tube																														
6ft	46"SP	6ft																												
110	135	180																												
36 disc	<table border="1" style="margin: auto;"> <tr><td colspan="3">120in Mnt tube</td></tr> <tr><td>6ft</td><td>46"SP</td><td>6ft</td></tr> <tr><td>180</td><td>135</td><td>110</td></tr> </table>	120in Mnt tube			6ft	46"SP	6ft	180	135	110	<table border="1" style="margin: auto;"> <tr><td colspan="3">132in Mnt tube</td></tr> <tr><td>6ft</td><td>46"SP</td><td>8ft</td></tr> <tr><td>40</td><td>0</td><td>40</td></tr> </table>	132in Mnt tube			6ft	46"SP	8ft	40	0	40	<table border="1" style="margin: auto;"> <tr><td colspan="3">120in Mnt tube</td></tr> <tr><td>6ft</td><td>46"SP</td><td>6ft</td></tr> <tr><td>110</td><td>135</td><td>180</td></tr> </table>	120in Mnt tube			6ft	46"SP	6ft	110	135	180
120in Mnt tube																														
6ft	46"SP	6ft																												
180	135	110																												
132in Mnt tube																														
6ft	46"SP	8ft																												
40	0	40																												
120in Mnt tube																														
6ft	46"SP	6ft																												
110	135	180																												

800NT SERIES DISC HARROW MOUNTING CHART

DISC MODEL	WINGS	MAIN FRAME			WINGS																											
		APPROX ARM LOCATION (IN FROM CENTER) SECTION, STUBS, SPANNERS & EXT																														
14 disc		<table border="1"> <tr><td colspan="3">100in Mnt tube</td></tr> <tr><td>8ft</td><td>46"SP</td><td>8ft</td></tr> <tr><td>52</td><td></td><td>52</td></tr> </table>			100in Mnt tube			8ft	46"SP	8ft	52		52																			
100in Mnt tube																																
8ft	46"SP	8ft																														
52		52																														
16 disc		<table border="1"> <tr><td colspan="3">100in Mnt tube</td></tr> <tr><td>6ft</td><td>46"SP</td><td>6ft</td><td>46"SP</td><td>6ft</td></tr> <tr><td>52</td><td></td><td>8</td><td></td><td>52</td></tr> </table>			100in Mnt tube			6ft	46"SP	6ft	46"SP	6ft	52		8		52															
100in Mnt tube																																
6ft	46"SP	6ft	46"SP	6ft																												
52		8		52																												
18 disc		<table border="1"> <tr><td colspan="3">100in Mnt tube</td></tr> <tr><td>6ft</td><td>46"SP</td><td>8ft</td><td>46"SP</td><td>6ft</td></tr> <tr><td>72</td><td></td><td>22</td><td></td><td>72</td></tr> </table>			100in Mnt tube			6ft	46"SP	8ft	46"SP	6ft	72		22		72															
100in Mnt tube																																
6ft	46"SP	8ft	46"SP	6ft																												
72		22		72																												
22 disc	<table border="1"> <tr><td colspan="3">78in Mnt tube</td></tr> <tr><td></td><td></td><td>8ft</td></tr> <tr><td>110</td><td></td><td>92</td></tr> </table>	78in Mnt tube					8ft	110		92	<table border="1"> <tr><td colspan="3">78in Mnt tube</td></tr> <tr><td></td><td></td><td>8ft</td></tr> <tr><td>22</td><td></td><td>22</td></tr> </table>			78in Mnt tube					8ft	22		22	<table border="1"> <tr><td colspan="3">78in Mnt tube</td></tr> <tr><td>8ft</td><td></td><td></td></tr> <tr><td>92</td><td></td><td>110</td></tr> </table>	78in Mnt tube			8ft			92		110
78in Mnt tube																																
		8ft																														
110		92																														
78in Mnt tube																																
		8ft																														
22		22																														
78in Mnt tube																																
8ft																																
92		110																														
24 disc	<table border="1"> <tr><td colspan="3">78in Mnt tube</td></tr> <tr><td></td><td></td><td>8ft</td></tr> <tr><td>145</td><td></td><td>110</td></tr> </table>	78in Mnt tube					8ft	145		110	<table border="1"> <tr><td colspan="3">78in Mnt tube</td></tr> <tr><td>6ft</td><td>38"SP</td><td>4ft</td></tr> <tr><td>45</td><td></td><td>45</td></tr> </table>			78in Mnt tube			6ft	38"SP	4ft	45		45	<table border="1"> <tr><td colspan="3">78in Mnt tube</td></tr> <tr><td>8ft</td><td></td><td></td></tr> <tr><td>110</td><td></td><td>145</td></tr> </table>	78in Mnt tube			8ft			110		145
78in Mnt tube																																
		8ft																														
145		110																														
78in Mnt tube																																
6ft	38"SP	4ft																														
45		45																														
78in Mnt tube																																
8ft																																
110		145																														
26 disc	<table border="1"> <tr><td colspan="3">78in Mnt tube</td></tr> <tr><td></td><td></td><td>8ft</td></tr> <tr><td>145</td><td></td><td>110</td></tr> </table>	78in Mnt tube					8ft	145		110	<table border="1"> <tr><td colspan="3">78in Mnt tube</td></tr> <tr><td>6ft</td><td>46"SP</td><td>6ft</td></tr> <tr><td>45</td><td></td><td>45</td></tr> </table>			78in Mnt tube			6ft	46"SP	6ft	45		45	<table border="1"> <tr><td colspan="3">78in Mnt tube</td></tr> <tr><td>8ft</td><td></td><td></td></tr> <tr><td>110</td><td></td><td>145</td></tr> </table>	78in Mnt tube			8ft			110		145
78in Mnt tube																																
		8ft																														
145		110																														
78in Mnt tube																																
6ft	46"SP	6ft																														
45		45																														
78in Mnt tube																																
8ft																																
110		145																														
30 disc	<table border="1"> <tr><td colspan="3">78in Mnt tube</td></tr> <tr><td></td><td></td><td>8ft</td></tr> <tr><td>155</td><td></td><td>122</td></tr> </table>	78in Mnt tube					8ft	155		122	<table border="1"> <tr><td colspan="3">100in Mnt tube</td></tr> <tr><td>8ft</td><td>46"SP</td><td>8ft</td></tr> <tr><td>45</td><td></td><td>45</td></tr> </table>			100in Mnt tube			8ft	46"SP	8ft	45		45	<table border="1"> <tr><td colspan="3">78in Mnt tube</td></tr> <tr><td>8ft</td><td></td><td></td></tr> <tr><td>122</td><td></td><td>155</td></tr> </table>	78in Mnt tube			8ft			122		155
78in Mnt tube																																
		8ft																														
155		122																														
100in Mnt tube																																
8ft	46"SP	8ft																														
45		45																														
78in Mnt tube																																
8ft																																
122		155																														
34 LNT disc	<table border="1"> <tr><td colspan="3">78in Mnt tube</td></tr> <tr><td>6ft</td><td>46"SP</td><td>6ft</td></tr> <tr><td>178</td><td>143</td><td>110</td></tr> </table>	78in Mnt tube			6ft	46"SP	6ft	178	143	110	<table border="1"> <tr><td colspan="3">100in Mnt tube</td></tr> <tr><td>6ft</td><td>46"SP</td><td>8ft</td></tr> <tr><td>45</td><td>2</td><td>45</td></tr> </table>			100in Mnt tube			6ft	46"SP	8ft	45	2	45	<table border="1"> <tr><td colspan="3">78in Mnt tube</td></tr> <tr><td>6ft</td><td>46"SP</td><td>6ft</td></tr> <tr><td>110</td><td>143</td><td>178</td></tr> </table>	78in Mnt tube			6ft	46"SP	6ft	110	143	178
78in Mnt tube																																
6ft	46"SP	6ft																														
178	143	110																														
100in Mnt tube																																
6ft	46"SP	8ft																														
45	2	45																														
78in Mnt tube																																
6ft	46"SP	6ft																														
110	143	178																														
38 LNT disc	<table border="1"> <tr><td colspan="3">78in Mnt tube</td></tr> <tr><td>8ft</td><td>46"SP</td><td>6ft</td></tr> <tr><td>178</td><td>143</td><td>110</td></tr> </table>	78in Mnt tube			8ft	46"SP	6ft	178	143	110	<table border="1"> <tr><td colspan="3">100in Mnt tube</td></tr> <tr><td>6ft</td><td>46"SP</td><td>8ft</td></tr> <tr><td>45</td><td>2</td><td>45</td></tr> </table>			100in Mnt tube			6ft	46"SP	8ft	45	2	45	<table border="1"> <tr><td colspan="3">78in Mnt tube</td></tr> <tr><td>6ft</td><td>46"SP</td><td>8ft</td></tr> <tr><td>110</td><td>143</td><td>178</td></tr> </table>	78in Mnt tube			6ft	46"SP	8ft	110	143	178
78in Mnt tube																																
8ft	46"SP	6ft																														
178	143	110																														
100in Mnt tube																																
6ft	46"SP	8ft																														
45	2	45																														
78in Mnt tube																																
6ft	46"SP	8ft																														
110	143	178																														

EXAMPLE FOR HARROW ASSEMBLY

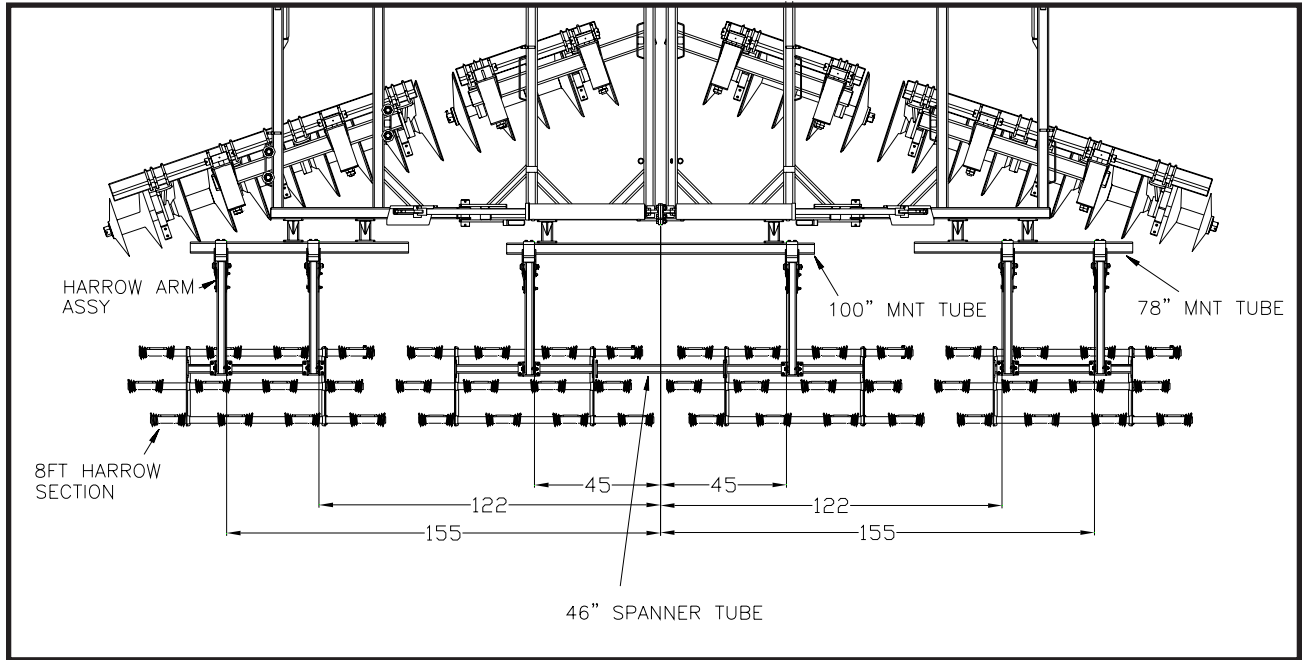

EXAMPLE 30FT DISC

DISC
MODEL
30 disc

WINGS	
78in Mnt tube	
	8ft
155	122

MAIN FRAME		
100in Mnt tube		
8ft	46"SP	8ft
45		45

WINGS	
78in Mnt tube	
8ft	
122	155